

THE MOTOR VEHICLE ACT, 1988

Sections	Contents	Page
	Introduction	1
CHAPTER I		
PRELIMINARY		
1.	Short title, extent and commencement	4
2 .	Definitions	4
CHAPTER II		
LICENSING OF DRIVER OF MOTOR VEHICLES		
3.	Necessity for driving license	9
4.	Age Limit in connection with driving of motor vehicles	9
5.	Responsibility of owners of motor vehicles for contravention of sections 3 and 4	9
6.	Restrictions on the holding of driving licenses	9
7.	Restrictions on the granting of learners licenses for certain vehicles	10
8.	Grant of learner's license	10
9.	Grant of driving license	11
10.	Form and contents of licenses to drive	13
11.	Additions to driving license	14
12.	Licensing and regulation of schools or establishments for imparting instruction in driving of motor vehicles	14
13.	Extent of effectiveness of license, to drive motor vehicles	15
14.	Currency of licenses to drive motor vehicles	15
15.	Renewal of driving licenses	16
16.	Revocation of driving license on grounds of disease or disability	17
17.	Orders refusing or revoking driving licenses and appeals there from	17
18.	Driving licenses to motor vehicles, belonging to the Central Government	18
19.	Power of licensing authority to disqualify from holding a driving license or revoke such license	18
20.	Power of Court to disqualify	19
21.	Suspension of driving license in certain cases	20
22.	Suspension or cancellation of driving license on conviction	21
23.	Effect of disqualification order	21
24.	Endorsement	22
25	Transfer of endorsement and issue of driving license free from endorsement	22
26.	Maintenance of State Registers of Driving Licenses	23
27.	Power of Central Government to make rules	24
28.	Power of State Government to make rules	25

Sections	Contents	Page
CHAPTER III		
LICENSING OF CONDUCTORS OF STAGE CARRIAGES		
29.	Necessity for conductor's license	26
30.	Grant of conductor's license	26
31.	Disqualifications for the grant of conductor's license	26
32.	Revocation of a conductor's license on grounds of disease or disability	27
33.	Orders refusing etc., conductor's licenses and appeals there from	27
34.	Power of licensing authority to disqualify	27
35.	Power of Court to disqualify	28
36.	Certain provisions of Chapter II to apply to conductor's license	28
37.	Savings	28
38.	Power of State Government to make rules	28
CHAPTER IV		
REGISTRATION OF MOTOR VEHICLES		
39.	Necessity for registration	30
40.	Registration, where to be made	30
41.	Registration, how to be made	30
42.	Special provision for registration of motor vehicles of diplomatic officers, etc	35
43.	Temporary ,registration	35
44.	Production of vehicle at the time of registration	36
45.	Refusal of registration or renewal of the certificate of registration	36
46.	Effectiveness in India of registration	36
47.	Assignment of new registration mark on removal to another State	36
48.	No objection certificate	38
49.	Change of residence or place of business	38
50.	Transfer of ownership	39
51.	Special provisions regarding motor vehicle subject to hire purchase agreement, etc.	41
52.	Alteration in motor vehicle	43
53.	Suspension of registration	44
54.	Cancellation of registration suspended under section 53	45
55.	Cancellation of registration	45
56.	Certificate of fitness of transport vehicles	46
57.	Appeals	47
58.	Special provisions in regard to transport vehicles	47
59.	Power to fix the age limit of motor vehicle	48

Sections	Contents	Page
60.	Registration of vehicles belonging to the Central Government	48
61.	Application of Chapter to trailers	49
62.	Information regarding stolen and recovered motor vehicles to be furnished by the police to the State Transport Authority	49
63.	Maintenance of State Registers of Motor vehicles	49
64.	Power of the Central Government to make rules	50
65.	Power of State Government to make rules	51
CHAPTER V		
CONTROL OF TRANSPORT VEHICLES		
66.	Necessity for permits	53
67.	Power to State Government to control road transport	55
68.	Transport authorities	56
69.	General provision as to applications for permits	57
70.	Application for stage carriage permit	58
71.	Procedure of Regional Transport Authority in considering application for stage carriage permit	58
72.	Grant of stage carriage permit	59
73.	Application for contract carriage permit	62
74.	Grant of contract carriage permit	62
75.	Scheme for renting of motor cabs	64
76.	Application for private service vehicle permit	64
77.	Application for goods carriage permit	65
78.	Consideration of application for goods carriage permit	66
79.	Grant of goods carriage permit	66
80.	Procedure in applying for and granting permits	67
81.	Duration and renewal of permits	68
82.	Transfer of permit	69
83.	Replacement of vehicles	70
84.	General conditions attaching to all permits	70
85.	General form of permits	71
86.	Cancellation and suspension of permits	71
87.	Temporary permits	72
88.	Validation of permits for use outside region in which granted	73
89.	Appeals	76
90.	Revision	77
91.	Restriction of hours of work of drivers	77
92.	Voidance of contracts restrictive of liability	78
93.	Agent or canvasser to obtain license	78
94.	Bar or jurisdiction of Civil courts	79

Sections	Contents	Page
95.	Power of State Government to make rules as to stage carriages and contract carriage	79
96	Power of state Government to make rules for the purposes of this Chapter	79
CHAPTER VI		
SPECIAL PROVISIONS RELATING TO STATE TRANSPORT UNDERTAKINGS		
97.	Definition	83
98.	Chapter to override Chapter V and other laws	83
99.	Preparation and publication of proposal regarding road transport service of a State transport undertaking	83
100.	Objection to the proposal	83
101.	Operation of additional services by a State transport undertaking in certain circumstances	84
102.	Cancellation or modification of scheme	84
103.	Issue of permits to State transport undertakings	85
104.	Restriction of grant of permits in respect of a notified area or notified route	86
105.	Principles and method of determining compensation and payment thereof	86
106.	Disposal of articles found in vehicles	87
107.	Power of State Government to make rules	87
108.	Certain powers of State Government exercisable by the Central Government	88
CHAPTER VII		
CONSTRUCTION, EQUIPMENT AND MAINTENANCE OF MOTOR VEHICLES		
109.	General provision regarding construction and maintenance of vehicles	89
110.	Power of Central Government to make rules	89
111.	Power of State Government to make rules	90
CHAPTER VIII		
CONTROL OF TRAFFIC		
112.	Limits of speed	92
113.	Limits of weight and limitation on use	92
114.	Power to have vehicles weighed	93
115.	Power to restrict the use of vehicles	93
116.	Power to erect traffic signs	93
117.	Parking places and halting stations	94
118.	Driving regulations	95
119.	Duty to obey traffic signs	95

Sections	Contents	Page
120.	Vehicles with left hand control	95
121.	Signals and signaling devices	95
122.	Leaving vehicles in dangerous position	96
123.	Riding on running board, etc.	96
124.	Prohibition against traveling without pass or ticket	96
125.	Obstruction of driver	96
126.	Stationary vehicles	97
127.	Removal of motor vehicles abandoned or left unattended on a public place	97
128.	Safety measures for drivers and pillion riders	97
129.	Wearing of protective headgear	98
130.	Duty to produce license and certificate of registration	98
131.	Duty to the driver to take certain precautions at unguarded railway level crossings	99
132.	Duty of driver to stop in certain cases	99
133.	Duty of owner of motor vehicle to give information	100
134.	Duty of driver in case of accident and injury to a person	100
135.	Schemes to be framed for the investigation of accident cases and wayside amenities, etc.	101
136.	Inspection of vehicle involved in accident	101
137.	Power of Central Government to make rules	101
138.	Power of State Government to make rules	101
CHAPTER IX		
MOTOR VEHICLES TEMPORARILY LEAVING OR VISITING INDIA		
139.	Power of Central Government to make rules	103
CHAPTER X		
LIABILITY WITHOUT FAULT IN CERTAIN CASES		
140.	Liability to pay compensation in certain cases on the principle of no fault	105
141.	Provisions as to other right to claim compensation for death or permanent disablement	105
142.	Permanent disablement	106
143.	Applicability of Chapter to certain claims under Act 8 of 1923	106
144.	Overriding effect	106
CHAPTER XI		
INSURANCE OF MOTOR VEHICLES AGAINST THIRD PARTY RISKS		
145.	Definitions	107
146.	Necessity for insurance against third party risk	107
147.	Requirements of policies and limits of liability	108
148.	Validity of Policies of insurance issued in reciprocating Countries	110

Sections	Contents	Page
149.	Duty of insurers to satisfy judgments and awards against persons insured in respect of third party risks	110
150.	Rights of third parties against insurers on insolvency of the insured	112
151.	Duty to give information as to insurance	113
152.	Settlement between insurers and insured persons	114
153.	Saving in respect of sections 150, 151 and 152	114
154.	Insolvency of insured persons not to affect liability of insured or claims by third parties	114
155.	Effect of death on certain causes of action	114
156.	Effect of certificate of insurance	114
157.	Transfer of certificate of Insurance	115
158.	Production of certain certificates, license and permit in certain cases	115
159.	Production of certificate of insurance on application for authority to use vehicle	116
160.	Duty to furnish particulars of vehicle involved in accident	117
161.	Special provisions as to compensation in case of hit and run motor accident	117
162.	Refund in certain cases of compensation paid under section 161	118
163.	Scheme for payment of compensation in case of hit and run motor accidents	118
163A.	Special provisions as to payment of compensation on structured formula basis	119
163B.	Option to file claim in certain cases	119
164.	Power of Central Government to make rules	120
CHAPTER XII		
CLAIMS TRIBUNALS		
165.	Claims Tribunals	121
166.	Application for compensation	121
167.	Option regarding claims for compensation in certain cases	122
168.	Award of the Claims Tribunal	122
169.	Procedure and Powers of Claims Tribunals	123
170.	Impleading insurer in certain cases	123
171.	Award of interest where any claim is allowed	123
172.	Award of compensatory costs in certain cases	123
173.	Appeals	124
174.	Recovery of money from insurer as arrears of land revenue	124
175.	Bar on jurisdiction of Civil Courts	124
176.	Power of State Government to make rules	125
CHAPTER XIII		
OFFENCES, PENALTIES AND PROCEDURE		
177.	General provision for punishment of offences	126

Sections	Contents	Page
178.	Penalty for traveling without pass or ticket and for dereliction of duty on the part of conductor and refusal to ply contract carriage, etc	126
179.	Disobedience of orders, obstruction and refusal of information	127
180.	Allowing unauthorised persons to drive vehicles	127
181.	Driving vehicles in contravention of section 3 or section 4	127
182.	Offences relating to licenses	127
183.	Driving at excessive speed etc.	128
184.	Driving dangerously	128
185.	Driving by a drunken person or by a person under the influence of drugs	128
186.	Driving when mentally or physically unfit to drive	129
187.	Punishment for offences relating to accident	129
188.	Punishment for abetment of certain offences	129
189.	Racing and trials of speed	129
190.	Using vehicle in unsafe condition	129
191.	Sale of vehicle in or alteration of vehicle to condition contravening this Act	130
192.	Using vehicles without registration	130
192A.	Using vehicle without permit	131
193.	Punishment of agents and canvassers without proper authority	131
194.	Driving vehicle exceeding permissible weight	131
195.	Imposition of minimum fine under certain circumstances	132
196.	Driving uninsured vehicle	132
197.	Taking vehicle without authority	132
198.	Unauthorised interference with vehicle	132
199.	Offences by companies	133
200.	Composition of certain offences	133
201.	Penalty for causing obstruction to free flow of traffic	134
202.	Power to arrest without warrant	134
203.	Breath tests	134
204.	Laboratory test	135
205.	Presumption of unfitness to drive	136
206.	Power of police officer to impound to drive	136
207.	Power to detain vehicles used without certificate of registration permit, etc.	137
208.	Summary disposal of cases	137
209.	Restriction on conviction	138
210.	Courts to send intimation about conviction	139

Sections	Contents	Page
CHAPTER XIV		
MISCELLANEOUS		
211.	Power of levy fee	140
212.	Publication commencement and laying of rules and notifications	140
213.	Appointment of motor vehicles officers	141
214.	Effect of appeal and revision on orders passed by original authority	142
215.	Road Safety Councils and Committees	142
216.	Power to remove difficulties	143
217.	Repeal and savings	143
217A.	Renewal of permits, driving licences and registration granted under the Motor Vehicles Act, 1939.	144
	THE FIRST SCHEDULE-Mandatory Signs	145
	THE SECOND SCHEDULE-Schedule for compensation for third party fatal accident/injury cases claims	181

THE MOTOR VEHICLES ACT, 1988

INTRODUCTION

The first enactment relating to motor vehicles in India was the Indian Motor Vehicles Act, 1914, which was subsequently replaced by the Motor Vehicles Act, 1939. The Act of 1939 had been amended several times. In spite of several amendments it was felt necessary to bring out a comprehensive legislation keeping in view the changes in the transport technology, pattern of passenger and freight movements, development of the road network in the country and particularly the improved techniques in the motor vehicles management. Various Committees as well as the Law Commission had gone into different aspects of road transport. Several Members of Parliament had also urged for comprehensive review of the Motor Vehicles Act, 1939. A Working Group was, therefore, constituted in January, 1984 to review all the provisions of the Act of 1939. This Working Group took into account the suggestions and recommendations earlier made by various bodies and institutions and made certain recommendations. On the recommendations of the Working Group State Governments were asked to submit their comments. The recommendations made by the Working Group and comments received from the State Governments were discussed at a special meeting of Transport Ministers of all States and Union Territories. Based on the conclusions reached in the meeting of Transport Ministers and suggestions made by the Supreme Court in a case the Motor Vehicles Bill was introduced in the Parliament.

STATEMENT OF OBJECTS AND REASONS

The Motor Vehicles Act, 1939 (4 of 1939), consolidates and amends the law relating to motor vehicles. This has been amended several times to keep it up-to-date. The need was, however, felt that this Act should, now *inter alia*, take into account also changes in the road transport technology, pattern of passenger and freight movements, development of the road network in the country and particularly the improved techniques in the motor vehicles management.

Various Committees like National Transport Policy Committee, National Police Commission, Road Safety Committee, Low Powered Two-wheelers Committee, as also the Law Commission have gone into different aspects of road transport. They have recommended updating, simplification and rationalization of this law. Several Members of Parliament have also urged for comprehensive review of the Motor Vehicles Act, 1939, to make it relevant to the modern-day requirements.

A Working Group was, therefore, constituted in January, 1984 to review all the provisions of the Motor Vehicles Act, 1939, and to submit draft proposals for a comprehensive legislation to replace the existing Act. This Working Group took into account the suggestions and recommendations earlier made by various bodies and institutions like Central Institute of Road Transport, Automotive Research Association of India, and other transport organisations including the manufacturers and the general public. Besides, obtaining comments of State Governments on the recommendations of the Working Group, these were discussed in a specially convened meeting of Transport Ministers of all States and Union Territories. Some of the more important modifications

so suggested related fortaking care of

- (a) the fast increasing number of both commercial vehicles and personal vehicles in the country;
- (b) the need for encouraging adoption of higher technology in automotive sector;
- (c) the greater flow of passenger and freight with the least impediments so that islands of isolations are not created leading to regional or local imbalances;
- (d) concern for road safety standards, and pollution-control measures, standards for transportation of hazardous and explosive materials;
- (e) simplification of procedure and policy liberalizations for private sector operations in the road transport field; and
- (f) need for effective ways of tracking down traffic offenders.

The Supreme Court in *M.K. Kunhimohammed v. P.A. Ahmedkutty*, (1987) 4 SCC 284: AIR 1987 SC 2158, has made certain suggestions to raise the limit of compensation payable as a result of motor accidents in respect of death and permanent disablement in the event of there being no proof of fault on the part of the person involved in the accident and also in hit and run motor accidents and to remove certain disparities in the liability of the insurer to pay compensation depending upon the class or type of vehicles involved in the accident. The above suggestions made by the Supreme Court have been incorporated in the Bill.

The proposed legislation has been prepared in the light of the above background. Some of the more important provisions of the Bill provide for the following matters, namely:-

- (a) rationalization of certain definitions with additions of certain new definitions of new types of vehicles;
- (b) stricter procedures relating to grant of driving licences and the period of validity thereof;
- (c) laying down of standards for the components and parts of motor vehicles;
- (d) standards for anti-pollution control devices;
- (e) provision for issuing fitness certificates of vehicles also by the authorised testing stations;
- (f) enabling provision for updating the system of registration marks;
- (g) liberalised schemes for grant of stage carriage permits on non-nationalised routes, All India Tourist Permits and also national permits for goods carriages;
- (h) administration of the Solatium Scheme by the General Insurance Corporation;
- (i) provision for enhanced compensation in cases of "no fault liability" and in "hit and run" motor accidents;
- (j) provision for payment of compensation by the insurer to the extent of actual

- liability to the victims of motor accidents irrespective of the class of vehicles;
- (k) maintenance of State registers for driving licences and vehicle registration;
- (l) constitution of Road Safety Councils.

The Bill also seeks to provide for more deterrent punishment in the cases of certain offences.

The Notes on clauses explain the provisions of the Bill.

The Bill seeks to achieve the above objectives.

ACT 59 OF 1988

The Motor Vehicles Bill having been passed by both the Houses of Parliament, received the assent of the President on 14th October, 1988. It came into force on 1st day of July, 1989, as The MOTOR VEHICLES ACT, 1988 (59 of 1988).

AMENDING ACT'S

1. The Motor Vehicles (Amendment) Act, 1994 (54 of 1994).
2. The Motor Vehicles (Amendment) Act, 2000 (27 of 2000).
3. The Motor Vehicles (Amendment) Act, 2001 (39 of 2001).

THE MOTOR VEHICLES ACT, 1988

(59 of 1988)

[14th October, 1988]

An Act to consolidate and amend the law relating to motor vehicles.

Be it enacted by parliament in the Thirty-ninth Year of the Republic of India as follows : -

1. Short title, extent and commencement-

- (1) This Act may be called the Motor Vehicles Act, 1988.
- (2) It extends to the whole of India.
- (3) It shall come into force on such date as the central Government may, by notification in the Official Gazette, appoint; and different dates may be appointed for different States and any reference in this Act to the commencement of this act shall, in relation to a State, be construed as a reference to the coming into force of this Act in that State.

2. Definitions-In this Act, unless the context otherwise requires,-

- (1) "area," in relation to any provision of this Act, means such area as the State Government may, having regard to the requirements of that provision, specify by notification in the Official Gazette;
- (2) "articulated vehicle" means a motor vehicle to which a semi-trailer is attached;
- (3) "axle weight" means in relation to an axle of a vehicle the total weight transmitted by the several wheels attached to that axle to the surface on which the vehicle rests;
- (4) "certificate of registration" means the certificate issued by a competent authority to the effect that a motor vehicle has been duly registered in accordance with the provisions of Chapter IV;
- (5) "conductor", in relation to a stage carriage, means a person engaged in collecting fares from passengers, regulating their entrance into, or exit from, the stage carriage and performing such other functions as may be prescribed;
- (6) "conductor's license" means the license issued by a competent authority under Chapter III authorising the person specified therein to act as a conductor;
- (7) "contract carriage" means a motor vehicle which carries a passenger or passengers for hire or reward and is engaged under a contract, whether expressed or implied, for the use of such vehicle as a whole for the carriage of passengers mentioned therein and entered into by a person with a holder of a permit in relation to such vehicle or any person authorised by him in this behalf on a fixed or an agreed rate or sum-

1. Came into force on 1-7-1989. Vide S.O. 368 (E), dated 22nd May, 1989, published in the Gazette of India, Extra., Pt. II, Sec. 3 (ii), dated 22nd May, 1989.

(a) on a time basis, whether or not with reference to any route or distance; or

(b) from one point to another,

and in either case, without stopping to pick up or set down passengers not included in the contract anywhere during the journey, and includes-

(i) a maxicab; and

(ii) a motorcar notwithstanding the separate fares are charged for its passengers;

(8) "dealer" includes a person who is engaged-

¹[***]

(b) in building bodies for attachment to chassis; or

(c) in the repair of motor vehicles; or

(d) in the business of hypothecation, leasing or hire-purchase of motor vehicle;

(9) "driver" includes, in relation to a motor vehicle which is drawn by another motor vehicle, the person who acts as a steersman of the drawn vehicle;

(10) "driving licence" means the licence issued by a competent authority under Chapter II authorising the person specified therein to drive, otherwise than as a learner, a motor vehicle or a motor vehicle of any specified class or description;

(11) "educational institution bus" means an omnibus, which is owned by a college, school or other educational institution and used solely for the purpose of transporting students or staff of the educational institution in connection with any of its activities;

(12) "fares" includes sums payable for a season ticket or in respect of the hire of a contract carriage;

(13) "goods" includes livestock, and anything (other than equipment ordinarily used with the vehicle) carried by a vehicle except living persons, but does not include luggage or personal effects carried in a motor car or in a trailer attached to a motor car or the personal luggage of passengers travelling in the vehicle;

(14) "goods carriage" means any motor vehicle constructed or adapted for use solely for the carriage of goods, or any motor vehicle not so constructed or adapted when used for the carriage of goods;

(15) "gross vehicle weight" means in respect of any vehicle the total weight of the vehicle and load certified and registered by the registering authority as permissible for that vehicle;

1. Sub-clause (a) omitted by Act 54 of 1994, sec. 2 (w.e.f. 14-11-1994).

- (16) "heavy goods vehicle" means any goods carriage the gross vehicle weight of which, or a tractor or a road-roller the unladen weight of either of which, exceeds 12,000 kilograms;
- (17) "heavy passenger motor vehicle" means any public service vehicle or private service vehicle or educational institution bus or omnibus the gross vehicle weight of any of which, or a motor car the unladen weight of which, exceeds 12,000 kilograms;
- (18) "invalid carriage" means a motor vehicle specially designed and constructed, and not merely adapted, for the use of a person suffering from some physical defect or disability, and used solely by or for such a person;
- (19) "learner's licence" means the licence issued by a competent authority under Chapter II authorising the person specified therein to drive as a learner, a motor vehicle or a motor vehicle of any specified class or description;
- (20) "licensing authority" means an authority empowered to issue licences under Chapter II or, as the case may be, Chapter III;
- (21) "light motor vehicle" means a transport vehicle or omnibus the gross vehicle weight of either of which or a motor car or tractor or road-roller the unladen weight of any of which, does not exceed ¹[7500] kilograms;
- ²[(21A) "manufacturer" means a person who is engaged in the manufacture of motor vehicles;]
- (22) "maxicab" means any motor vehicle constructed or adapted to carry more than six passengers, but not more than twelve passengers, excluding the driver, for hire or reward;
- (23) "medium goods vehicle" means any goods carriage other than a light motor vehicle or a heavy goods vehicle;
- (24) "medium passenger motor vehicle" means any public service vehicle or private service vehicle, or educational institution bus other than a motor cycle, invalid carriage, light motor vehicle or heavy passenger motor vehicle;
- (25) "motorcab" means any motor vehicle constructed or adapted to carry not more than six passengers excluding the driver for hire or reward;
- (26) "motor car" means any motor vehicle other than a transport vehicle, omnibus, road-roller, tractor, motor cycle or invalid carriage;
- (27) "motor cycle" means a two-wheeled motor vehicle, inclusive of any detachable side-car having an extra wheel, attached to the motor vehicle;
- (28) "motor vehicle" or "vehicle" means any mechanically propelled vehicle adapted for use upon roads whether the power of propulsion is transmitted thereto from an external or

1. Subs, by Act 54 of 1994, sec. 2, for "6000" (w.e.f. 14-11-1994).

2. Ins. by Act 54 of 1994, sec. 2 (w.e.f. 14-11-1994).

internal source and includes a chassis to which a body has not been attached and a trailer; but does not include a vehicle running upon fixed rails or a vehicle of a special type adapted for use only in a factory or in any other enclosed premises or a vehicle having less than four wheels fitted with engine capacity of not exceeding ¹[twenty-five cubic centimetres];

- (29) "omnibus" means any motor vehicle constructed or adapted to carry more than six persons excluding the driver;
- (30) "owner" means a person in whose name a motor vehicle stands registered, and where such person is a minor, the guardian of such minor, and in relation to a motor vehicle which is the subject of a hire-purchase, agreement, or an agreement of lease or an agreement of hypothecation, the person in possession of the vehicle under that agreement;
- (31) "permit" means a permit issued by a State or Regional Transport Authority or an authority prescribed in this behalf under this Act authorising the use of a motor vehicle as a transport vehicle;
- (32) "prescribed" means prescribed by rules made under this Act;
- (33) "private service vehicle" means a motor vehicle constructed or adapted to carry more than six persons excluding the driver and ordinarily used by or on behalf of the owner of such vehicle for the purpose of carrying persons for, or in connection with, his trade or business otherwise than for hire or reward but does not include a motor vehicle used for public purposes;
- (34) "public place" means a road, street, way or other place, whether a thoroughfare or not, to which the public have a right of access, and includes any place or stand at which passengers are picked up or set down by a stage carriage;
- (35) "public service vehicle" means any motor vehicle used or adapted to be used for the carriage of passengers for hire or reward, and includes a maxicab, a motorcab, contract carriage, and stage carriage;
- (36) "registered axle weight" means in respect of the axle of any vehicle, the axle weight certified and registered by the registering authority as permissible for that axle;
- (37) "registering authority" means an authority empowered to register motor vehicles under Chapter IV;
- (38) "route" means a line of travel which specifies the highway which may be traversed by a motor vehicle between one terminus and another;
- ²[(39) "semi-trailer" means a vehicle not mechanically propelled (other than a trailer), which is intended to be connected to a motor vehicle and which is so constructed that a portion of it is super-imposed on, ; and a part of whose weight is borne by, that motor vehicle;] ;

1. Subs, by Act 54 of 1994, sec. 2, for "thirty-five cubic centimetres" (w.e.f. 14-11-1994).

2. Subs, by Act 54 of 1994, sec. 2, for "thirty-five cubic centimetres" (w.e.f. 14-11-1994).

- (40) "stage carriage" means a motor vehicle constructed or adapted to carry more than six passengers excluding the driver for hire or reward at separate fares paid by or for individual passengers, either for the whole journey or for stages of the journey;
- (41) "State Government" in relation to a Union territory means the Administrator thereof appointed under article 239 of the Constitution;
- (42) "State transport undertaking" means any undertaking providing road transport service, where such undertaking is carried on by,-
- (i) the Central Government or a State Government;
 - (ii) any Road Transport Corporation established under section 3 of the Road Transport Corporations Act, 1950 (64 of 1950);
 - (iii) any municipality or any corporation or company owned or controlled by the Central Government or one or more State Governments, or by the Central Government and one or more State Governments.
 - ¹[(iv) Zila Parishad or any other similar local authority.]
- Explanation.-For the purposes of this clause, "road transport service" means a service of motor vehicles carrying passengers or goods or both by road for hire or reward;
- (43) "tourist vehicle" means a contract carriage, constructed or adapted and equipped and maintained in accordance with such specifications as may be prescribed in this behalf;
- (44) "tractor" means a motor vehicle which is not itself constructed to ; carry any load (other than equipment used for the purpose of propulsion); but excludes a road-roller;
- (45) "traffic signs" includes all signals, warning sign posts, direction posts, markings on the road or other devices for the information, guidance or direction of drivers of motor vehicles;
- (46) "trailer" means any vehicle, other than a semi-trailer and a side-car, drawn or intended to be drawn by a motor vehicle;
- (47) "transport vehicle" means a public service vehicle, a goods carriage, an educational institution bus or a private service vehicle;
- (48) "unladen weight" means the weight of a vehicle or trailer including all equipment ordinarily used with the vehicle or trailer when working, but excluding the weight of a driver or attendant; and where alternative parts or bodies are used the unladen weight of the vehicle means the weight of the vehicle with the heaviest such alternative part or body;
- (49) "weight" means the total weight transmitted for the time being by the wheels of a vehicle to the surface on which the vehicle rests. ;

1. Ins. by Act 54 of 1994, sec. 2 (w.e.f. 14-11-1994).

CHAPTER II LICENSING OF DRIVERS OF MOTOR VEHICLES

3. Necessity for driving licence.

(1) No person shall drive a motor vehicle in any public place unless he holds an effective driving licence issued to him authorising him to drive the vehicle; and no person shall so drive a transport vehicle [other than ¹[a motor cab or motor cycle] hired for his own use or rented under any scheme made under sub-section (2) of section 75] unless his driving licence specifically entitles him so to do.

(2) The conditions subject to which sub-section (1) shall not apply to a person receiving instructions in driving a motor vehicle shall be such as may be prescribed by the Central Government.

4. Age limit in connection with driving of motor vehicles.

(1) No person under the age of eighteen years shall drive a motor vehicle in any public place:

Provided that ²[a motor cycle with engine capacity not exceeding 50cc] may be driven in a public place by a person after attaining the age of sixteen years.

(2) Subject to the provisions of section 18, no person under the age of twenty years shall drive a transport vehicle in any public place.

(3) No learner's licence or driving licence shall be issued to any person to drive a vehicle of the class to which he has made an application unless he is eligible to drive that class of vehicle under this section.

5. Responsibility of owners of motor vehicles for contravention of sections 3 and 4.

No owner or person in charge of a motor vehicle shall cause or permit any person who does not satisfy the provisions of section 3 or section 4 to drive the vehicle.

6. Restriction on the holding of driving licences

(1) No person shall come while he holds any driving licence for the time being in force, hold any other driving licence except a learner's licence or a driving licence issued in accordance with the provisions of section 18 or a document authorising, in accordance with the rules made under section 139, the person specified therein to drive a motor vehicle.

(2) No holder of a driving licence or a learner's licence shall permit it to be used by any other person.

1. Subs. by Act 54 of 1994, sec. 3, for "a motor cab" (w.e.f. 14-11-1994).

2. Subs. by Act 54 of 1994, sec. 4, for "a motor cycle without gear" (w.e.f. 14-11-1994).

(3) Nothing in this section shall prevent a licensing authority having the jurisdiction referred to in sub-section (1) of section 9 from adding to the classes of vehicles which the driving licence authorises the holder to drive.

7. Restrictions on the granting of learner's licences for certain vehicles.

¹ [(1)No person shall be granted a learner's licence to drive a transport vehicle unless he has held a driving licence to drive a light motor vehicle for at least one year.]

(2) No person under the age of eighteen years shall be granted a learner's licence to drive a motor cycle without gear except with the consent in writing of the person having the care of the person desiring the learner's licence.

8. Grant of learner's licence.

(1) Any person who is not disqualified under section 4 for driving a motor vehicle and who is not for the time being disqualified for holding or obtaining a driving licence may, subject to the provisions of section 7, apply to the licensing authority having jurisdiction in the area-

(i) in which he ordinarily resides or carries on business, or

(ii) in which the school or establishment referred to in section 12 from where he intends to receive instruction in driving a motor vehicle is situate, for the issue to him of a learner's licence.

(2) Every application under sub-section (1) shall be in such form and shall be accompanied by such documents and with such fee as may be prescribed by the Central Government.

(3) Every application under sub-section (1) shall be accompanied by a medical certificate in such form as may be prescribed by the Central Government and signed by such registered medical practitioner, as the State Government or any person authorised in this behalf by the State Government may, by notification in the Official Gazette, appoint for this purpose:

²[Provided that no such medical certificate is required for licence to drive a vehicle other than a transport vehicle.]

(4) If, from the application or from the medical certificate referred to in subsection (3), it appears that the applicant is suffering from any disease or disability which is likely to cause the driving by him of a motor vehicle of the class which he would be authorised by the learner's licence applied for to drive to be a source of danger to the public or to the passengers, the licensing authority shall refuse to issue the learner's licence:

Provided that a learner's licence limited to driving an invalid carriage may be issued to the applicant, if the licensing authority is satisfied that he is fit to drive such a carriage.

1. Subs. by Act 54 of 1994, sec. 5, for sub-section (1) (w.e.f. 14-11-1994).

2. Added by Act 54 of 1994, sec. 6 (w.e.f. 14-11-1994).

(5) No learner's licence shall be issued to any applicant unless he passes to the satisfaction of the licensing authority such test as may be prescribed by the Central Government.

(6) When an application has been duly made to the appropriate licensing authority and the applicant has satisfied such authority of his physical fitness under sub-section (3) and has passed to the satisfaction of the licensing authority the test referred to in sub-section (5), the licensing authority shall, subject to the provisions of section 7, issue the applicant a learner's licence unless the applicant is disqualified under section 4 for driving a motor vehicle or is for the time being disqualified for holding or obtaining a licence to drive a motor vehicle:

Provided that a licensing authority may issue a learner's licence to drive a motor cycle or a light motor vehicle notwithstanding that it is not the appropriate licensing authority, if such authority is satisfied that there is good reason for the applicant's inability to apply to the appropriate licensing authority.

(7) Where the Central Government is satisfied that it is necessary or expedient so to do, it may, by rules made in this behalf, exempt generally, either absolutely or subject to such conditions as may be specified in the rules, any class of persons from the provisions of sub-section (3), or sub-section (5), or both.

(8) Any learner's licence for driving a motor cycle in force immediately before the commencement of this Act shall, after such commencement, be deemed to be effective for driving a motor cycle with or without gear.

9. Grant of driving licence.

(1) Any person who is not for the time being disqualified for holding or obtaining a driving licence may apply to the licensing authority having jurisdiction in the area-

(i) in which he ordinarily resides or carries on business, or

(ii) in which the school or establishment referred to in section 12 from where he is receiving or has received instruction in driving a motor vehicle is situated.

for the issue to him of a driving licence.

(2) Every application under sub-section (1) shall be in such form and shall be accompanied by such fee and such documents as may be prescribed by the Central Government.

¹[(3) If the applicant passes such test as may be prescribed by the Central Government, he shall be issued the driving licence:

Provided that no such test shall be necessary where the applicant produces proof to show that-

1. Subs. by Act 54 of 1994, sec. 7, for sub-section (3) (w.e.f. 14-11-1994).

- (a) (i) the applicant has previously held a driving licence to drive such class of vehicle and that the period between the date of expiry of that licence and the date of the application does not exceed five years, or
- (ii) the applicant holds or has previously held a driving licence to drive such class of vehicle issued under section 18, or
- (iii) the applicant holds a driving licence to drive such class of vehicle issued by a competent authority of any country outside India, subject to the condition that the applicant complies with the provisions of sub-section (3) of section 8,
- (b) the applicant is not suffering from any disability which is likely to cause the driving by him to be a source of danger to the public; and the licensing authority may, for that purpose, require the applicant to produce a medical certificate in the same form and in the same manner as is referred to in sub-section (3) of section 8:

Provided further that where the application is for a driving licence to drive a motor vehicle (not being a transport vehicle), the licensing authority may exempt the applicant from the test of competence to drive a vehicle prescribed under this sub-section, if the applicant possesses a driving certificate issued by any institution recognised in this behalf by the State Government.]

(4) Where the application is for a licence to drive a transport vehicle, no such authorisation shall be granted to any applicant unless he possesses such minimum educational qualification as may be prescribed by the Central Government and a driving certificate issued by a school or establishment referred to in section 12.

¹[(5) Where the applicant does not pass the test, he may be permitted to reappear for the test after a period of seven days:

Provided that where the applicant does not pass the test even after three appearances, he shall not be qualified to re-appear for such test before the expiry of a period of sixty days from the date of last such test.]

(6) The test of competence to drive shall be carried out in a vehicle of the type to which the application refers:

Provided that a person who passed a test in driving a motor cycle with gear shall be deemed also to have passed a test in driving a motor cycle without gear.

(7) When any application has been duly made to the appropriate licensing authority and the applicant has satisfied such authority of his competence to drive, the licensing authority shall issue the applicant a driving licence unless the applicant is for the time being disqualified for holding or obtaining a driving licence:

Provided that a licensing authority may issue a driving licence to drive a motor cycle or a light motor vehicle notwithstanding that it is not the appropriate licensing authority, if the licensing authority is satisfied that there is good and sufficient reason for the applicant's inability to apply to the appropriate licensing authority:

1. Subs by Act 54 of 1994, sec. 7, for sub-section (5) (w.e.f. 14-11-1994).

Provided further that the licensing authority shall not issue a new driving licence to the applicant, if he had previously held a driving licence, unless it is satisfied that there is good and sufficient reason for his inability to obtain a duplicate copy of his former licence.

(8) If the licensing authority is satisfied, after giving the applicant an opportunity of being heard, that he-

(a) is a habitual criminal or a habitual drunkard; or

(b) is a habitual addict to any narcotic drug or psychotropic substance within the meaning of the Narcotic Drugs and Psychotropic Substances Act, 1985 (61 of 1985); or

(c) is a person whose licence to drive any motor vehicle has, at any time earlier, been revoked,

it may, for reasons to be recorded in writing, make an order refusing to issue a driving licence to such person and any person aggrieved by an order made by a licensing authority under this sub-section may, within thirty days of the receipt of the order, appeal to the prescribed authority.

(9) Any driving licence for driving a motor cycle in force immediately before the commencement of this Act shall, after such commencement, be deemed to be effective for driving a motor cycle with or without gear.

10. Form and contents of licences to drive.

(1) Every learner's licence and driving licence, except a driving licence issued under section 18, shall be in such form and shall contain such information as may be prescribed by the Central Government.

(2) A learner's licence or, as the case may be, driving licence shall also be expressed as entitling the holder to drive a motor vehicle of one or more of the following classes, namely:-

(a) motor cycle without gear;

(b) motor cycle with gear;

(c) invalid carriage;

(d) light motor vehicle;

¹[(e) transport vehicle;]

(i) road-roller;

(j) motor vehicle of a specified description.

1. Subs. by Act 54 of 1994, sec. 8, for clauses (e) to (h) (w.e.f. 14-11-1994).

11. Additions to driving licence.

(1) Any person holding a driving licence to drive any class or description of motor vehicles, who is not for the time being disqualified for holding or obtaining a driving licence to drive any other class or description of motor vehicles, may apply to the licensing authority having jurisdiction in the area in which he resides or carries on his business in such form and accompanied by such documents and with such fees as may be prescribed by the Central Government for the addition of such other class or description of motor vehicles to the licence.

(2) Subject to such rules as may be prescribed by the Central Government, the provisions of section 9 shall apply to an application under this section as if the said application was for the grant of a licence under that section to drive the class or description of motor vehicles which the applicant desires to be added to his licence.

12. Licensing and regulation of schools or establishments for imparting instruction in driving of motor vehicles.

(1) The Central Government may make rules for the purpose of licensing and regulating, by the State Governments, schools or establishments (by whatever name called) for imparting instruction in driving of motor vehicles and matters connected therewith.

(2) In particular, and without prejudice to the generality of the foregoing power, such rules may provide for all or any of the following matters, namely:-

- (a) licensing of such schools or establishments including grant, renewal and revocation of such licences;
- (b) supervision of such schools or establishments;
- (c) the form of application and the form of licence and the particulars to be contained therein;
- (d) fee to be paid with the application for such licences;
- (e) conditions subject to which such licences may be granted;
- (f) appeals against the orders of refusal to grant or renew such licences and appeals against the orders revoking such licences;
- (g) conditions subject to which a person may establish and maintain any such school or establishment for imparting instruction in driving of motor vehicles;
- (h) nature, syllabus and duration of course or courses for efficient instruction in driving any motor vehicle;
- (i) apparatus and equipments (including motor vehicles fitted with dual control) required for the purpose of imparting such instruction;

- (j) suitability of the premises at which such schools or establishments may be established or maintained and facilities to be provided therein;
- (k) qualifications, both educational and professional (including experience), which a person imparting instruction in driving a motor vehicle shall possess;
- (l) inspection of such schools and establishments (including the services rendered by them and the apparatus, equipments and motor vehicles maintained by them for imparting such instruction);
- (m) maintenance of records by such schools or establishments;
- (n) financial stability of such schools or establishments;
- (o) the driving certificates, if any, to be issued by such schools or establishments and the form in which such driving certificates shall be issued and the requirements to be complied with for the purposes of issuing such certificates;
- (p) such other matters as may be necessary to carry out the purposes of this section.

(3) Where the Central Government is satisfied that it is necessary or expedient so to do, it may, by rules made in this behalf, exempt generally, either absolutely or subject to such conditions as may be specified in the rules, any class of schools or establishments imparting instruction in driving of motor vehicles or matters connected therewith from the provisions of this section.

(4) A school or establishment imparting instruction in driving of motor vehicles or matters connected therewith immediately before the commencement of this Act, whether under a licence or not, may continue to impart such instruction without a licence issued under this Act for a period of one month from such commencement, and if it has made an application for such licence under this Act within the said period of one month and such application is in the prescribed form, contains the prescribed particulars and is accompanied by the prescribed fee, till the disposal of such application by the licensing authority.

13. Extent of effectiveness of licences, to drive motor vehicles.

A learner's licence or a driving licence issued under this Act shall be effective throughout India.

14. Currency of licences to drive motor vehicles.

- (1) A learner's licence issued under this Act shall, subject to the other provisions of this Act, be effective for a period of six months from the date of issue of the licence.
- (2) A driving licence issued or renewed under this Act shall,-
 - (a) in the case of a licence to drive a transport vehicle, be effective for a period of three years: ¹[***]

1. The word "and" omitted by Act 54 of 1994, sec. 9 (w.e.f. 14-11-1994).

¹[Provided that in the case of licence to drive a transport vehicle carrying goods of dangerous or hazardous nature be effective for a period of one year and renewal thereof shall be subject to the condition that the driver undergoes one day refresher course of the prescribed syllabus; and]

(b) in the case of any other licence,-

(i) if the person obtaining the licence, either originally or on renewal thereof, has not attained the age of ¹[fifty years] on the date of issue or, as the case may be, renewal thereof,-

(A) be effective for a period of twenty years from the date of such issue or renewal; or

(B) until the date on which such person attains the age of ²[fifty years],whichever is earlier;

³[(ii) if the person referred to in sub-clause (i), has attained the age of fifty years on the date of issue or as the case may be, renewal thereof, be effective, on payment of such fee as may be prescribed, for a period of five years from the date of such issue or renewal:]

Provided that every driving licence shall, notwithstanding its expiry under this sub-section continue to be effective for a period of thirty days from such expiry.

15. Renewal of driving licences.

(1) Any licensing authority may, on application made to it, renew a driving licence issued under the provisions of this Act with effect from the date of its expiry:

Provided that in any case where the application for the renewal of a licence is made more than thirty days after the date of its expiry, the driving licence shall be renewed with effect from the date of its renewal:

Provided further that where the application is for the renewal of a licence to drive a transport vehicle or where in any other case the applicant has attained the age of forty years, the same shall be accompanied by a medical certificate in the same form and in the same manner as is referred to in sub-section (3) of section 8, and the provisions of sub-section (4) of section 8 shall, so far as may be, apply in relation to every such case as they apply in relation to a learner's licence.

(2) An application for the renewal of a driving licence shall be made in such form and accompanied by such documents as may be prescribed by the Central Government.

1. Ins. by Act 54 of 1994, sec. 9 (w.e.f. 14-11-1994).

2. Subs. by Act 54 of 1994, sec. 9, for "forty years" (w.e.f. 14-11-1994).

3. Subs. by Act 54 of 1994, sec. 9, (w.e.f. 14-11-1994).

(3) Where an application for the renewal of a driving licence is made previous to, or not more than thirty days after the date of its expiry, the fee payable for such renewal shall be such as may be prescribed by the Central Government in this behalf.

(4) Where an application for the renewal of a driving licence is made more than thirty days after the date of its expiry the fee payable for such renewal shall be such amount as may be prescribed by the Central Government:

Provided that the fee referred to in sub-section (3) may be accepted by the licensing authority in respect of an application for the renewal of a driving licence made under this sub-section if it is satisfied that the applicant was prevented by good and sufficient cause from applying within the time specified in such-section (3):

Provided further that if the application is made more than five years after the driving licence has ceased to be effective the licensing authority may refuse to renew the driving licence unless the applicant, undergoes and passes to its satisfaction the test of competence to drive referred to in sub-section (3) of section 9.

(5) Where the application for renewal has been rejected, the fee paid shall be I refunded to such extent and in such manner as may be prescribed by the Central Government.

(6) Where the authority renewing the driving licence is not the authority which issued the driving licence it shall intimate the fact of renewal to the authority which issued the driving licence

16. Revocation of driving licence on grounds of disease or disability.

Notwithstanding anything contained in the foregoing sections, any licensing authority may at any time revoke a driving licence or may require, as a condition of continuing to hold such driving licence, the holder thereof to produce a medical certificate in the same form and in the same manner as is referred to in sub-section (3) of section 8, if the licensing authority has reasonable grounds to believe that the holder of the driving licence is, by virtue of any disease of disability, unfit to drive a motor vehicle and where the authority revoking a driving licence is not the authority which issued the same, it shall intimate the fact of revocation to the authority which issued that licence.

17. Orders refusing or revoking driving licences and appeals therefrom.

(1) Where a licensing authority refuses to issue any learner's licence or to issue or renew, or revokes any driving licence, or refuses to add a class or description of motor vehicle to any driving licence, it shall do so by an order communicated to the applicant or the holder, as the case may be, giving the reasons in writing for such refusal or revocation.

(2) Any person aggrieved by an order made under sub-section (1) may within thirty days of the service on him of the order, appeal to the prescribed authority which shall decide the appeal after giving such person and the authority which made the order an opportunity of being heard and the decision of the appellate authority shall be binding on the authority which made the order.

18. Driving licences to drive motor vehicles, belonging to the Central Government.

- (1) Such authority as may be prescribed by the Central Government may issue driving licence valid throughout India to persons who have completed their eighteenth year to drive motor vehicles which are the property or for the time being under the exclusive control of the Central Government and are used for Government purposes relating to the defence of the country and unconnected with any commercial enterprise.
- (2) A driving licence issued under this section shall specify the class or description of vehicle which the holder is entitled to drive and the period for which he is so entitled.
- (3) A driving licence issued under this section shall not entitle the holder to drive any motor vehicle except a motor vehicle referred to in sub-section (1).

19. Power of licensing authority to disqualify from holding a driving licence or revoke such licence.

- (1) If a licensing authority is satisfied, after giving the holder of a driving licence an opportunity of being heard, that he-
 - (a) is a habitual criminal or habitual drunkard; or
 - (b) is a habitual addict to any narcotic drug or psychotropic substance within the meaning of the Narcotic Drugs and Psychotropic Substances Act, 1985 (61 of 1985); or
 - (c) is using or has used a motor vehicle in the commission of a cognizable offence; or
 - (d) has by his previous conduct as driver of a motor vehicle shown that his driving is likely to be attended with danger to the public; or
 - (e) has obtained any driving licence or a licence to drive a particular class or description of motor vehicle by fraud or misrepresentation; or
 - (f) has committed any such act which is likely to cause nuisance or danger to the public, as may be prescribed by the Central Government, having regard to the objects of this Act; or
 - (g) has failed to submit to, or has not passed, the tests referred to in the proviso to sub-section (3) of section 22; or
 - (h) being a person under the age of eighteen years who has been granted a learner's licence or a driving licence with the consent in writing of the person having the care of the holder of the licence and has ceased to be in such care,

it may, for reasons to be recorded in writing, make an order-

 - (i) disqualifying that person for a specified period for holding on obtaining any driving licence to drive all or any classes or descriptions of vehicles specified in the licence; or

(ii) revoke any such licence.

(2) Where an order under sub-section (1) is made, the holder of a driving licence shall forthwith surrender his driving licence to the licensing authority making the order, if the driving licence has not already been surrendered, and the licensing authority shall,-

- (a) if the driving licence is a driving licence issued under this Act, keep it until the disqualification has expired or has been removed; or
- (b) if it is not a driving licence issued under this Act, endorse the disqualification upon it and send it to the licensing authority by which it was issued; or
- (c) in the case of revocation of any licence, endorse the revocation upon it and if it is not the authority which issued the same, intimate the fact of revocation to the authority which issued that licence:

Provided that where the driving licence of a person authorises him to drive more than one class or description of motor vehicles and the order, made under sub-section (1), disqualifies him from driving any specified class or description of motor vehicles, the licensing authority shall endorse the disqualification upon the driving licence and return the same to the holder.

(3) Any person aggrieved by an order made by a licensing authority under sub-section (1) may, within thirty days of the receipt of the order, appeal to the prescribed authority, and such appellate authority shall give notice to the licensing authority and hear either party if so required by that party and may pass such order as it thinks fit and an order passed by any such appellate authority shall be final

20. Power of Court to disqualify.

(1) Where a person is convicted of an offence under this Act or of an offence in the commission of which a motor vehicle was used, the court by which such person is convicted may, subject to the provisions of this Act, in addition to imposing any other punishment authorised by law, declare the person so convicted to be disqualified, for such period as the Court may specify, from holding any driving licence to drive all classes to description of vehicles, or any particular class or description of such vehicles, as are specified in such licence:

Provided that in respect of an offence punishable under section 183 no such order shall be made for the first or second offence.

(2) Where a person is convicted of an offence under clause (c) of sub-section (1) of section 132, section 134 or section 185, the Court convicting any person of any such offence shall order the disqualification under sub-section (1), and if the offence is relatable to clause (c) of sub-section (1) of section 132 or section 134, such disqualification shall be for a period of not less than one month, and if the offence is relatable to section 185, such disqualification shall be for a period of not less than six months.

(3) A Court shall, unless for special reasons to be recorded in writing it thinks fit to order otherwise, order the disqualification of a person-

- (a) who having been convicted of an offence punishable under section 184 is again convicted of an offence punishable under that section,
- (b) who is convicted of an offence punishable under section 189, or
- (c) who is convicted of an offence punishable under section 192:

Provided that the period of disqualification shall not exceed, in the case referred to in clause (a), five years, or in the case referred to in clause (b), two years or, in the case referred to in clause (c), one year.

(4) A Court ordering the disqualification of a person convicted of an offence punishable under section 184 may direct that such person shall, whether he has previously passed the test of competence to drive as referred to in sub-section (3) of section 9 or not, remain disqualified until he has subsequent to the making of the order of disqualification passed that test to the satisfaction of the licensing authority.

(5) The court to which an appeal would ordinarily lie from any conviction of an offence of the nature specified in sub-section (1) may set aside or vary any order of disqualification made under that sub-section notwithstanding that no appeal would lie against the conviction as a result of which such order of disqualification was made.

21. Suspension of driving licence in certain cases.

(1) Where, in relation to a person who had been previously convicted of an offence punishable under section 184, a case is registered by a police officer on the allegation that such person has, by such dangerous driving as is referred to in the said section 184, of any class or description of motor vehicle caused the death of, or grievous hurt to, one or more persons, the driving licence held by such person shall in relation to such class or description of motor vehicle become suspended-

(a) for a period of six months from the date on which the case is registered, or

(b) if such person is discharged or acquitted before the expiry of the period aforesaid, until such discharge or acquittal, as the case may be.

(2) Where by virtue of the provisions of sub-section (1), the driving licence held by a person becomes suspended, the police officer, by whom the case referred to in sub-section (1) is registered, shall bring such suspension to the notice of the Court competent to take cognizance of such offence, and thereupon, such Court shall take possession of the driving licence, endorse the suspension thereon and intimate the fact of such endorsement to the licensing authority by which the licence was granted or last renewed.

(3) Where the person referred to in sub-section (1) is acquitted or discharged, the Court shall cancel the endorsement on such driving licence with regard to the suspension thereof.

(4) If a driving licence in relation to a particular class or description of motor vehicles is suspended under sub-section (1), the person holding such licence shall be debarred from holding or obtaining any licence to drive such particular class or description of motor vehicles so long as the suspension of the driving licence remains in force.

22. Suspension or cancellation of driving licence on conviction.

(1) Without prejudice to the provisions of sub-section (3) of section 20 where a person, referred to in sub-section (1) of section 21, is convicted of an offence of causing, by such dangerous driving as is referred to in section 184 of any class or description of motor vehicle the death of, or grievous hurt to, one or more persons, the Court by which such person is convicted may cancel, or suspend for such period as it may think fit, the driving licence held by such person in so far as it relates to that class or description of motor vehicle.

(2) Without prejudice to the provisions of sub-section (2) of section 20, if a person, having been previously convicted of an offence punishable under section 185 is again convicted of an offence punishable under that section, the Court, making such subsequent conviction, shall, by order, cancel the driving licence held by such person.

(3) If a driving licence is cancelled or suspended under this section, the court shall take the driving licence in its custody, endorse the cancellation or, as the case may be, suspension, thereon and send the driving licence so endorsed to the authority by which the licence was issued or last renewed and such authority shall, on receipt of the licence, keep the licence in its safe custody, and in the case of a suspended licence, return the licence to the holder thereof after the expiry of the period of suspension on an application made by him for such return:

Provided that no such licence shall be returned unless the holder thereof has, after the expiry of the period of suspension, undergone and passed, to the satisfaction of the licensing authority by which the licence was issued or last renewed, a fresh test of competence to drive referred to in sub-section (3) of section 9 and produced a medical certificate in the same form and in the same manner as is referred to in sub-section (3) of section 8.

(4) If a licence to drive a particular class or description of motor vehicles is cancelled or suspended under this section, the person holding such a licence shall be debarred from holding, or obtaining, any licence to drive such particular class or description of motor vehicles so long as the cancellation or suspension of the driving licence remains in force.

23. Effect of disqualification order.

(1) A person in respect of whom any disqualification order is made under section 19 or section 20 shall be debarred to the extent and for the period specified in such order from holding or obtaining a driving licence and the driving licence, if any, held by such person at the date of the order shall cease to be effective to such extent and during such period.

(2) The operation of a disqualification order made under section 20 shall not be suspended or postponed while an appeal is pending against such order or against the conviction as a result of which such order is made, unless the appellate Court so directs.

(3) Any person in respect of whom any disqualification order has been made may at any time after the expiry of six months from the date of the order apply to the Court or other

authority by which the order was made, to remove the disqualification; and the Court or authority, as the case may be, may, having regard to all the circumstances, either cancel or vary the disqualification order:

Provided that where the Court or other authority refuses to cancel or vary any disqualification order under this section, a second application thereunder shall not be entertained before the expiry of a period of three months from the date of such refusal.

24. Endorsement.

(1) The Court or authority making an order of disqualification shall endorse or cause to be endorsed upon the driving licence if any, held by the person disqualified, particulars of the order of disqualification and of any conviction of an offence in respect of which an order of disqualification is made; and particulars of any cancellation or variation of an order of disqualification made under sub-section (3) of section 23 shall be similarly so endorsed.

(2) A Court by which any person is convicted of an offence under this Act as may be prescribed by the Central Government, having regard to the objects of this Act, shall whether or not a disqualification order is made in respect of such conviction, endorse or cause to be endorsed particulars at such conviction on any driving licence held by the person convicted.

(3) Any person accused of an offence prescribed under sub-section (2) shall when attending the Court bring with him his driving licence if it is in his possession.

(4) Where any person is convicted of any offence under this Act and sentenced to imprisonment for a period exceeding three months, the Court awarding the sentence shall endorse the fact of such sentence upon the driving licence of the person concerned and the prosecuting authority shall intimate the fact of such endorsement to the authority by which the driving licence was granted or last renewed.

(5) When the driving licence is endorsed or caused to be endorsed by any Court, such Court shall send the particulars of the endorsement to the licensing authority by which the driving licence was granted or last renewed.

(6) Where on an appeal against any conviction or order of a Court, which has been endorsed on a driving licence, the appellate court varies or sets aside the conviction or order, the appellate court shall inform the licensing authority by which the driving licence was granted or last renewed and such authority shall amend or cause to be amended the endorsement.

25. Transfer of endorsement and issue of driving licence free from endorsement.

(1) An endorsement on any driving licence shall be transferred to any new or duplicate driving licence obtained by the holder thereof until the holder becomes entitled under the provisions of this section to have a driving licence issued to him free from endorsement.

(2) Where a driving licence is required to be endorsed and the driving licence is not in the possession of the Court or authority by which the endorsement is to be made, then-

- (a) if the person in respect of whom the endorsement is to be made is at the time the holder of a driving licence, he shall produce the driving licence to the Court or

authority within five days, or such longer time as the court or authority may fix; or

- (b) if, not being then the holder of a driving licence, he subsequently obtains a driving licence, he shall within five days after obtaining the driving licence produce it to the Court or authority,

and if the driving licence is not produced within the time specified, it shall, on the expiration of such time, be of no effect until it is produced for the purpose; of endorsement.

- (3) A person whose driving licence has been endorsed shall, if during a continuous period of three years after such endorsement no further endorsement has been made against him, be entitled on surrendering his driving licence and on payment of a fee of five rupees, to receive a new driving licence free from all endorsements:

Provided that if the endorsement is only in respect of an offence contravening the speed limits referred to in section 112, such person shall be entitled to receive a new driving licence free from such endorsements on the expiration of one year of the date of the endorsement:

Provided further that in reckoning the said period of three years and one year, respectively, and period during which the said person was disqualified for holding or obtaining a driving licence shall be excluded.

26. Maintenance of State Registers of Driving Licences.

- (1) Each State Government shall maintain, in such form as may be prescribed by the Central Government, a register to be known as the State Register of Driving Licences, in respect of driving licences issued and renewed by the licensing authorities of the State Government, containing the following particulars, namely:-

- (a) names and addresses of holders of driving licences;
- (b) licence numbers;
- (c) dates of issue or renewal of licences;
- (d) dates of expiry of licences;
- (e) classes and types of vehicles authorised to be driven; and
- (f) such other particulars as the Central Government may prescribe.

- (2) Each State Government shall supply to the Central Government a¹[printed copy or copy in such other form as the Central Government may require], of the State Register of Driving Licences and shall inform the Central Government without delay of all additions to and other amendments in such register made from time to time.

- (3) The State Register of Driving Licences shall be maintained in such manner as may be prescribed by the State Government.

1. Subs, by Act 54 of 1994, sec. 10, for "printed copy" (w.e.f. 14-11-1994).

27. Power of Central Government to make rules.

The Central Government may make rules-

- (a) regarding conditions referred to in such-section (2) of section 3;
- (b) providing for the form in which the application for learner's licence may be made, the information it shall contain and the documents to be submitted with the application referred to in sub-section (2) of section 8;
- (c) providing for the form of medical certificate referred to in subsection (3) of section 8;
- (d) providing for the particulars for the test referred to in sub-section (5) of section 8;
- (e) providing for the form in which the application for driving licence may be made, the information it shall contain and the documents to be submitted with the application referred to in sub-section (2) of section 9;
- (f) providing for the particulars regarding test of competence to drive, referred to in sub-section (3) of section 9;
- (g) specifying the minimum educational qualifications of persons to whom licences to drive transport vehicles may be issued under this Act and the time within which such qualifications are to be acquired by such persons;
- (h) providing for the form and contents of the licences referred to in subsection (1) of section 10;
- (i) providing for the form and contents of the application referred to in sub-section (1) of section 11 and documents to be submitted with the application and the fee to be charged;
- (j) providing for the conditions subject to which section 9 shall apply to an application made under section 11;
- (k) providing for the form and contents of the application referred to in sub-section (1) of section 15 and the documents to accompany such application under sub-section (2) of section 15;
- (l) providing for the authority to grant licences under sub-section (1) of section 18;
- (m) specifying the fees payable under sub-section (2) of section 8, sub section (2) of section 9 and sub-sections (3) and (4) of section 15 for the grant of learner's licences, and for the grant and renewal of driving licences and licences for the purpose of regulating the schools or establishments for imparting instructions in driving motor vehicles;
- (n) specifying the acts for the purposes of clause (f) of sub-section (1) of section 19;

- (o) specifying the offences under this Act for the purposes of sub-section (2) of section 24;
- (p) to provide for all or any of the matters referred to in sub-section (1) of section 26;
- (q) any other matter which is, or has to be, prescribed by the Central Government.

28. Power of State Government to make rules.

(1) A State Government may make rules for the purpose of carrying into effect the provisions of this Chapter other than the matters specified in section 27.

(2) Without prejudice to the generality of the foregoing power, such rules may provide for-

- (a) the appointment, jurisdiction, control and functions of licensing authorities and other prescribed authorities;
- (b) the conduct and hearing of appeals that may be preferred under the Chapter, the fees to be paid in respect of such appeals and the refund of such fees:

Provided that no fee so fixed shall exceed twenty-five rupees;

- (c) the issue of duplicate licences to replace licences lost, destroyed or mutilated, the replacement of photographs which has become ' obsolete and the fees to be charged therefore;
- (d) the badges and uniform to be worn by drivers of transport vehicles and the fees to be paid in respect of badges; ;
- (e) the fee payable for the issue of a medical certificate under sub-section (3) of section 8;
- (f) the exemption of prescribed persons, or prescribed classes of : persons, from payment of all or any portion of the fees payable I under this Chapter;
- (g) the communication of particulars of licences granted by one licensing authority to other licensing authorities;
- (h) the duties, functions and conduct of such persons to whom licences to drive transport vehicles are issued;
- (i) the exemption of drivers of road-rollers from all or any of the provisions of this Chapter or of the rules made thereunder;
- (j) the manner in which the State Register of Driving Licences shall be maintained under section 26;
- (k) any other matter which is to be, or may be, prescribed.

CHAPTER III

LICENSING OF CONDUCTORS OF STAGE CARRIAGES

29. Necessity for conductor's licence.

- (1) No person shall act as a conductor of a stage carriage unless he holds an effective conductor's licence issued to him authorising him to act as such conductor; and no person shall employ or permit any person who is not so licensed to act as a conductor of a stage carriage.
- (2) A State Government may prescribe the conditions subject to which subsection (1) shall not apply to a driver of a stage carriage performing the functions of a conductor or to a person employed to act as a conductor for a period not exceeding one month.

30. Grant of conductor's licence.

- (1) Any person who possesses such minimum educational qualification as may be prescribed by the State Government and is not disqualified under sub-section (1) of section 31 and who is not for the time being disqualified for holding or obtaining a conductor's licence may apply to the licensing authority having jurisdiction in the area in which he ordinarily resides or carries on business for the issue to him of a conductor's licence.
- (2) Every application under sub-section (1) shall be in such form and shall contain such information as may be prescribed.
- (3) Every application for a conductor's licence shall be accompanied by a medical certificate in such form as may be prescribed, signed by a registered medical practitioner and shall also be accompanied by two clear copies of a recent photograph of the applicant.
- (4) A conductor's licence issued under this Chapter shall be in such form and contain such particulars as may be prescribed and shall be effective throughout the State in which it is issued.
- (5) The fee for a conductor's licence and for each renewal thereof shall be one-half of that for a driving licence.

31. Disqualifications for the grant of conductor's licence.

- (1) No person under the age of eighteen years shall hold, or be granted, a conductor's licence.
 - (2) The licensing authority may refuse to issue a conductor's licence-
 - (a) if the applicant does not possess the minimum educational qualification;
 - (b) if the medical certificate produced by the applicant discloses that he is physically unfit to act as a conductor; and
 - (c) if any previous conductor's licence held by the applicant was revoked.
-

32. Revocation of a conductor's licence on grounds of disease or disability.

A conductor's licence may at any time be revoked by any licensing authority if that authority has reasonable grounds to believe that the holder of the licence is suffering from any disease or disability which is likely to render him permanently unfit to hold such a licence and where the authority revoking a conductor's licence is not the authority which issued the same, it shall intimate the fact of such revocation to the authority which issued that licence:

Provided that before revoking any licence, the licensing authority shall give the person holding such licence a reasonable opportunity of being heard.

33. Orders refusing etc., conductor's licences and appeals therefrom.

(1) Where a licensing authority refuses to issue or renew, or revokes any conductor's licence, it shall do so by an order communicated to the applicant or the holder, as the case may be, giving the reasons in writing for such refusal or revocation.

(2) Any person aggrieved by an order made under sub-section (1) may, within thirty days of the service on him of the order, appeal to the prescribed authority which shall decide the appeal after giving such person and the authority which made the order an opportunity of being heard and the decision of the appellate authority shall be binding on the authority which made the order.

34. Power of licensing authority to disqualify.

(1) If any licensing authority is of opinion that it is necessary to disqualify the holder of a conductor's licence for holding or obtaining such a licence on account of his previous conduct as a conductor, it may, for reasons to be recorded, make an order disqualifying that person for a specified period, not exceeding one year, for holding or obtaining a conductor's licence:

Provided that before disqualifying the holder of a licence, the licensing authority shall give the person holding such licence a reasonable opportunity of being heard.

(2) Upon the issue of any such order, the holder of the conductor's licence shall forthwith surrender the licence to the authority making the order, if the licence has not already been surrendered, and the authority shall keep the licence until the disqualification has expired or has been removed.

(3) Where the authority disqualifying the holder of a conductor's licence under this section is not the authority which issued the licence, it shall intimate the fact of such disqualification to the authority which issued the same.

(4) Any person aggrieved by an order made under sub-section (1) may, within thirty days of the service on him of the order, appeal to the prescribed authority which shall decide the appeal after giving such person and the authority which made the order an opportunity of being heard and the decision of the appellate authority shall be binding on the authority which made the order.

35. Power of Court to disqualify.

(1) Where any person holding a conductor's licence is convicted of an offence under this Act, the court by which such person is convicted may, in addition to imposing any other punishment authorised by law, declare the person so convicted to be disqualified for such period as the Court may specify for holding a conductor's licence.

(2) The Court to which an appeal lies from any conviction of an offence under this Act may set aside or vary any order of disqualification made by the court below, and the court to which appeals ordinarily lie from such Court, may set aside or vary any order of disqualification made by that Court, notwithstanding that no appeal lies against the conviction in connection with which such order was made

36. Certain provisions of Chapter II to apply to conductor's licence.

The provisions of sub-section (2) of section 6, sections 14, 15 and 23, sub-section (1) of section 24 and section 25 shall, so far as may be, apply in relation to a conductor's licence, as they apply in relation to a driving licence.

37. Savings.

If any licence to act as a conductor of a stage carriage (by whatever name called) has been issued in any State and is effective immediately before the commencement of this Act, it shall continue to be effective, notwithstanding such commencement, for the period for which it would have been effective, if this Act had not been passed, and every such licence shall be deemed to be a licence issued under this Chapter as if this Chapter has been in force on the date on which that licence was granted.

38. Power of State Government to make rules.

(1) A State Government may make rules for the purpose of carrying into effect the provisions of this Chapter.

(2) Without prejudice to the generality of the foregoing power, such rules may provide for-

- (a) the appointment, jurisdiction, control and functions of licensing authorities and other prescribed authorities under this Chapter;
- (b) the conditions subject to which drivers of stage carriages performing the functions of a conductor and persons temporarily employed to act as conductors may be exempted from the provisions of subsection (1) of section 29;
- (c) the minimum educational qualifications of conductors; their duties and functions and the conduct of persons to whom conductor's licences are issued;
- (d) the form of application for conductor's licences or for renewal of such licences and the particulars it may contain;

- (e) the form in which conductor's licences may be issued or renewed and the particulars it may contain;
- (f) the issue of duplicate licences to replace licences lost, destroyed or mutilated, the replacement of photographs which have become obsolete and the fees to be charged therefor;
- (g) the conduct and hearing of appeals that may be preferred under this Chapter, the fees to be paid in respect of such appeals and the refund of such fees:

Provided that no fee so fixed shall exceed twenty-five rupees;

- (h) the badges and uniform to be worn by conductors of stage carriages and the fees to be paid in respect of such badges;
- (i) the grant of the certificates referred to in sub-section (3) of section 30 by registered medical practitioners and the form of such certificates;
- (j) the conditions subject to which, and the extent to which, a conductor's licence issued in another State shall be effective in the State;
- (k) the communication of particulars of conductor's licences from one authority to other authorities; and
- (l) any other matter which is to be, or may be, prescribed.

CHAPTER IV

REGISTRATION OF MOTOR VEHICLES

39. Necessity for registration.

No person shall drive any motor vehicle and no owner of a motor vehicle shall cause or permit the vehicle to be driven in any public place or in any other place unless the vehicle is registered in accordance with this Chapter and the certificate of registration of the vehicle has not been suspended or cancelled and the vehicle carries a registration mark displayed in the prescribed manner:

Provided that nothing in this section shall apply to a motor vehicle in possession of a dealer subject to such conditions as may be prescribed by the Central Government

40. Registration, where to be made.

Subject to the provisions of section 42, section 43 and section 60, every owner of a motor vehicle shall cause the vehicle to be registered by a registering authority in whose jurisdiction he has the residence or place of business where the vehicle is normally kept.

41. Registration, how to be made.

(1) An application by or on behalf of the owner of a motor vehicle for registration shall be in such form and shall be accompanied by such documents, particulars and information and shall be made within such period as may be prescribed by the Central Government:

Provided that where a motor vehicle is jointly owned by more persons than one, the application shall be made by one of them on behalf of all the owners and such applicant shall be deemed to be the owner of the motor vehicle for the purposes of this Act.

(2) An application referred to in sub-section (1) shall be accompanied by such fee as may be prescribed by the Central Government.

(3) The registering authority shall issue to the owner of a motor vehicle registered by it a certificate of registration in such form and containing such particulars and information and in such manner as may be prescribed by the Central Government.

(4) In addition to the other particulars required to be included in the certificate of registration, it shall also specify the type of the motor vehicle, being a type as the Central Government may, having regard to the design construction and use of the motor vehicle, by notification in the Official Gazette, specify.

(5) The registering authority shall enter the particulars of the certificate referred to in sub-section (3) in a register to be maintained in such form and manner as may be prescribed by the Central Government.

(6) The registering authority shall assign to the vehicle, for display thereon, a distinguishing mark (in this Act referred to as the registration mark) consisting of one of the groups of such

of those letters and followed by such letters and figures as are allotted to the State by the Central Government from time to time by notification in the Official Gazette, and displayed and shown on the motor vehicle in such form and in such manner as may be prescribed by the Central Government.

(7) A certificate of registration issued under sub-section (3), whether before or after the commencement of this Act, in respect of a motor vehicle, other than a transport vehicle, shall, subject to the provisions contained in this Act, be valid only for a period of fifteen years from the date of issue of such certificate and shall be renewable.

(8) An application by or on behalf of the owner of a motor vehicle, other than a transport vehicle, for the renewal of a certificate of registration shall be made within such period and in such form, containing such particulars and information as may be prescribed by the Central Government.

(9) An application referred to in sub-section (8) shall be accompanied by such fee as may be prescribed by the Central Government.

(10) Subject to the provisions of section 56, the registering authority may, on receipt of an application under sub-section (8), renew the certificate of registration for a period of five years and intimate the fact to the original registering authority, if it is not the original registering authority.

(11) If the owner fails to make an application under sub-section (1), or, as the case may be, under sub-section (8) within the period prescribed, the registering authority may, having regard to the circumstances of the case, require the owner to pay, in lieu of any action that may be taken against him under section 177, such amount not exceeding one hundred rupees as may be prescribed under subsection (13):

Provided that action under section 177 shall be taken against the owner where the owner fails to pay the said amount.

(12) Where the owner has paid the amount under sub-section (11), no action shall be taken against him under section 177.

(13) For the purposes of sub-section (11), the State Government may prescribe different amounts having regard to the period of delay on the part of the owner in making an application under sub-section (1) or sub-section (8).

(14) An application for the issue of a duplicate certificate of registration shall be made to the 1[~~last~~ registering authority] in such form, containing such particulars and information along with such fee as may be prescribed by the Central Government.

1. Subs. by Act 54 of 1994, sec. 11, for "original registering authority" (w.e.f. 14-11-1994).

STATE AMENDMENT

Rajasthan:

In its application to the State of Rajasthan, in section 41,-

- (a) in sub-sections (7) and (8), the expression, "other than a transport vehicle," shall be omitted;
- (b) after sub-section (7) so amended, insert the following proviso, namely:- "Provided that in the case of transport vehicles, State Government may require the transport vehicles to be re-registered in the manner prescribed, subject to the age limit, if any, prescribed under section 59 of the Act."; and
- (c) in sub-section (10), after the words "for a period of five years" and before the words "and intimate", the expression "on payment of all taxes, penalties and interest, if any, levied by the State Government" shall be inserted.

[Rajasthan Act 1 of 2002, sec. 2 (w.e.f. 13-3-2002).]

NOTIFICATION

In exercise of the powers conferred by sub-section (4) of section 41 of the Motor Vehicles Act, 1988 (59 of 1988) and in supersession of the notification of the Government of India in the erstwhile Ministry of Surface Transport number S.0.451(E) dated the 19th June, 1992, the Central Government hereby specifies the types of motor vehicles as mentioned in columns 1 and 2 of the Table below for the purpose of said sub-section (4).

TABLE

<u>Transport Vehicle</u>	<u>Non- Transport Vehicle</u>
(i) Motor cycle with side car for carrying goods.	(i) Motor cycle with or without side car personal use.
(ii) Motor cycle with trailer to carry goods	(ii) Mopeds and motorized cycles (engine capacity exceeding 25 cc).
(iii) Motor cycle used for hire to carry one passenger on pillion and motorized cycle rickshaw for goods or passengers on hire.	(iii) Invalid carriage
(iv) Luxury Cab.	(iv) Three wheeled vehicle for personal use.
(v) Three wheeled vehicles for transport of passenger/ goods.	(v) Motor car.
(vi) Goods carrier trucks or tankers or mail carriers (N1 -N3 category).	(vi) Fork lift.
(vii) Power.tiller and Tractors using public roads	(vii) Vehicles or trailers fitted with equipments like Rig, generator, compressor
(viii) Mobile,clinic or X-Ray van or library vans	(viii) Crane mounted vehicle.
(ix) Mobile Workshops	(ix) Agricultural Tractor and Power Tiller

- | | |
|--|---|
| (x) Mobile canteens | (x) Private service Vehicle, registered in the name of an individual and if declared to be used by him solely for personal. |
| (xi) Private Service Vehicle | (xi) Camper van or trailer for private use |
| (xii) Public Service Vehicle such as maxi cab, motor cab, stage carriages and contract carriages including tourist vehicles. | (xii) Tow trucks, Breakdown Recovery Vehicles |
| (xiii) Educational Institution buses. | (xiii) Tower wagons and tree trimming vehicles owned by Central, State and local authorities. |
| (xiv) Ambulances [#] | (xiv) Construction Equipment Vehicles as defined in rule 2(ca)* |
| (xv) Animal ambulances ^{##} | |
| (xvi) Camper vans+ or trailers | |

(a) "Ambulance" means vehicle specially designed constructed or modified and equipped and intended to be used for emergency transportation of persons who are sick, injured, wounded or otherwise incapacitated.

(b) "Animal ambulance" means a motor vehicle intended to be used for the emergency transportation of sick, injured, wounded or otherwise incapacitated animals.

+ (c) "Camper van" means a special purpose MI category vehicle constructed to include living accommodation which contains at least the following equipment:

- Seats and table
- Sleeping accommodation which may be converted from the seats
- Cooking facilities, and Storage facilities

This equipment shall be rigidly fixed to the living compartment; however, the table may be designed to be easily removable.

++ (d) The "Omnibus" has been kept in the category of transport vehicle with a view to bringing it under the purview of fitness regime as it is exhaustively used on road. However, the taxes to be levied on such vehicle would fall within the jurisdiction of State Governments.

*(e) Under rule 2. (ca), use of public road by Construction Equipment Vehicles is incidental to the main off road function. However, when the public road is being used regularly for carrying on commercial activities, then Construction Equipment Vehicles such as dumpers and excavators being used for such activities, shall be deemed as transport vehicles.

Notification

In exercise of the powers conferred by sub-section (6) of the Act the Central Government has allotted to the States and Union Territories the groups of letters for the use as registration mark as given in table below-vide S.O. 444 (E), dated 12th June,1989 and as amended by S.O. 827 (E), dated 11th November,1992, by S.O. 1080 (E), dated 30th November,2000, by S.O. 14 (E), dated 5th January,2001 and S.O. 606 (E), dated 19th April,2007

	State/Union Territories	Group of letters		State/Union Territories	Group of letters
1.	Andaman and Nicobar	AN	17.	Lakashadeep	LD
2.	Andhra Pradesh	AP	18.	Madhya Pradesh	MP
3.	Arunachal Pradesh	AR	19.	Maharashtra	MH
4.	Assam	AS	20.	Manipur	MN
5.	Bihar	BR	21.	Meghalaya	ML
6.	Chandigarh	CH	22.	Mizoram	MZ
6A.	Chhatisgarh	CG	23.	Nagaland	NL
7.	Dadra and Nagar Haveli	DN	24.	Orissa	OR
8.	Daman and Diu	DD	25.	Pondicherry	PY
9.	Delhi	DL	26.	Punjab	PB
10.	Goa	GA	27.	Rajasthan	RJ
11.	Gujarat	GJ	28.	Sikkim	SK
12.	Haryana	HR	29.	Tamil Nadu	TN
13.	Himachal Pradesh	HP	30.	Tripura	TR
14.	Jammu and Kashmir	JK	31.	Uttar Pradesh	UP
14A.	Jharkhand	JH	31A.	Uttarakhand	UK
15.	Karnataka	KA	32.	West Bengal	WB
16.	Kerala	KL			

42. Special provision for registration of motor vehicles of diplomatic officers, etc.

(1) Where an application for registration of a motor vehicle is made under sub-section (1) of section 41 by or on behalf of any diplomatic officer or consular officer, then, notwithstanding anything contained in sub-section (3) or sub-section (6) of that section, the registering authority shall register the vehicle in such manner and in accordance with such procedure as may be provided by rules made in this behalf by the Central Government under sub-section

(3) and shall assign to the vehicle for display thereon a special registration mark in accordance with the provisions contained in those rules and shall issue a certificate (hereafter in this section referred to as the certificate of registration) that the vehicle has been registered under this section; and any vehicle so registered shall not, so long as it remains the property of any diplomatic officer or consular officer, require to be registered otherwise under this Act.

(2) If any vehicle registered under this section ceases to be the property of any diplomatic officer or consular officer, the certificate of registration issued under this section shall also cease to be effective, and the provisions of sections 39 and 40 shall thereupon apply.

(3) The Central Government may make rules for the registration of motor vehicles belonging to diplomatic officers and consular officers regarding the procedure to be followed by the registering authority for registering such vehicles, the form in which the certificates of registration of such vehicles are to be issued, the manner in which such certificates of registration are to be sent to the owners of the vehicles and the special registration marks to be assigned to such vehicles.

(4) For the purposes of this section, "diplomatic officer" or "consular officer" means any person who is recognised as such by the Central Government and if any question arises as to whether a person is or is not such an officer, the decision of the Central Government thereon shall be final.

43. Temporary registration.

(1) Notwithstanding anything contained in section 40 the owner of a motor vehicle may apply to any registering authority or other prescribed authority to have the vehicle temporarily registered in the prescribed manner and for the issue in the prescribed manner of a temporary certificate of registration and a temporary registration mark.

(2) A registration made under this section shall be valid only for a period not exceeding one month, and shall not be renewable:

Provided that where a motor vehicle so registered is a chassis to which a body has not been attached and the same is detained in a workshop beyond the said period of one month for being fitted ¹[with a body or any unforeseen circumstances beyond the control of the owner], the period may, on payment of such fees, if any, as may be prescribed, be extended by such further period or periods as the registering authority or other prescribed authority, as the case may be, may allow.

²[(3) In a case where the motor vehicle is held under hire-purchase agreement, lease or hypothecation, the registering authority or other prescribed authority shall issue a temporary certificate of registration of such vehicle, which shall incorporate legibly and prominently the full name and address of the person with whom such agreement has been entered into by the owner.]

1. Subs. by Act 54 of 1994, sec. 12, for "with a body" (w.e.f. 14-11-1994).

2. Ins. by Act 54 of 1994, sec. 12 (w.e.f. 14-11-1994).

44. Production of vehicle at the time of registration.

The registering authority shall before proceeding to register a motor vehicle or renew the certificate of registration in respect of a motor vehicle, other than a transport vehicle, require the person applying for registration of the vehicle or, as the case may be, for renewing the certificate of registration to produce the vehicle either before itself or such authority as the State Government may by order appoint in order that the registering authority may satisfy itself that the particulars contained in the application are true and that the vehicle complies with the requirements of this Act and of the rules made thereunder.

45. Refusal of registration or renewal of the certificate of registration.

The registering authority may, by order, refuse to register any motor vehicle, or renew the certificate of registration in respect of a motor vehicle (other than a transport vehicle), if in either case, the registering authority has reason to believe that it is a stolen motor vehicle or the vehicle is mechanically defective or fails to comply with the requirements of this Act or of the rules made thereunder, or if the applicant fails to furnish particulars of any previous registration of the vehicle or furnishes inaccurate particulars in the application for registration of the vehicle or, as the case may be, for renewal of the certificate or registration thereof and the registering authority shall furnish the applicant whose vehicle is refused registration, or whose application for renewal of the certificate of registration is refused, a copy of such order, together with the reasons for such refusal.

46. Effectiveness in India of registration.

Subject to the provisions of section 47, a motor vehicle registered in accordance with this Chapter in any State shall not require to be registered elsewhere in India and a certificate of registration issued or in force under this Act in respect of such vehicle shall be effective throughout India.

47. Assignment of new registration mark on removal to another State.

(1) When a motor vehicle registered in one State has been kept in another State, for a period exceeding twelve months, the owner of the vehicle shall, within such period and in such form containing such particulars as may be prescribed by the Central Government, apply to the registering authority, within whose jurisdiction the vehicle then is, for the assignment of a new registration mark and shall present the certificate of registration to that registering authority:

Provided that an application under this sub-section shall be accompanied-

- (i) by the no objection certificate obtained under section 48, or
- (ii) in a case where no such certificate has been obtained, by-
 - (a) the receipt obtained under sub-section (2) of section 48; or

(b) the postal acknowledgment received by the owner of the vehicle if he has sent an application in this behalf by registered post acknowledgment due to the registering authority referred to in section 48,

together with a declaration that he has not received any communication from such authority refusing to grant such certificate or requiring him to comply with any direction subject to which such certificate may be granted:

Provided further that, in a case where a motor vehicle is held under a hire-purchase, lease or hypothecation agreement, an application under this subsection shall be accompanied by a no objection certificate from the person with whom such agreement has been entered into, and the provisions of section 51, so far as may be, regarding obtaining of such certificate from the person with whom such agreement has been entered into, shall apply.

(2) The registering authority, to which application is made under sub-section (1), shall after making such verification, as it thinks fit, of the returns, if any, received under section 62, assign the vehicle a registration mark as specified in sub-section (6) of section 41 to be displayed and shown thereafter on the vehicle and shall enter the mark upon the certificate of registration before returning it to the applicant and shall, in communication with the registering authority by whom the vehicle was previously registered, arrange for the transfer of the registration of the vehicle from the records of that registering authority to its own records.

(3) Where a motor vehicle is held under a hire-purchase or lease or hypothecation agreement, the registering authority shall, after assigning the vehicle a registration mark under sub-section (2), inform the person whose name has been specified in the certificate of registration as the person with whom the registered owner has entered into the hire-purchase or lease or hypothecation agreement (by sending to such person a notice by registered post acknowledgment due at the address of such person entered in the certificate of registration the fact of assignment of the said registration mark).

(4) A State Government may make rules under section 65 requiring the owner of a motor vehicle not registered within the State, which is brought into or is for the time being in the State, to furnish to the prescribed authority in the State such information with respect to the motor vehicle and its registration as may be prescribed.

(5) If the owner fails to make an application under sub-section (1) within the period prescribed, the registering authority may, having regard to the circumstances of the case, require the owner to pay, in lieu of any action that may be taken against him under section 177, such amount not exceeding one hundred rupees as may be prescribed under sub-section (7):

Provided that action under section 177 shall be taken against the owner where the owner fails to pay the said amount.

(6) Where the owner has paid the amount under sub-section (5), no action shall be taken against him under section 177.

(7) For the purposes of sub-section (5), the State Government may prescribe different amounts having regard to the period of delay on the part of the owner in making an application under sub-section (1).

48. No objection certificate.

(1) The owner of a motor vehicle when applying for the assignment of a new registration mark under sub-section (1) of section 47, or where the transfer of a motor vehicle is to be effected in a State other than the State of its registration, the transferor of such vehicle where reporting the transfer under sub-section (1) of section 50, shall make an application in such form and in such manner as may be prescribed by the Central Government to the registering authority by which the vehicle was registered for the issue of a certificate (hereafter in this section referred to as the no objection certificate), to the effect that the registering authority has no objection for assigning a new registration mark to the vehicle or, as the case may be, for entering the particulars of the transfer of ownership in the certificate of registration.

(2) The registering authority shall, on receipt of an application under sub-section (1), issue a receipt in such form as may be prescribed by the Central Government.

(3) On receipt of an application under sub-section (1), the registering authority may, after making such inquiry and requiring the applicant to comply with such directions as it deems fit and within thirty days of the receipt thereof by order in writing, communicate to the applicant that it has granted or refused to grant the no objection certificate:

Provided that a registering authority shall not refuse to grant the no objection certificate unless it has recorded in writing the reasons for doing so and a copy of the same has been communicated to the applicant.

(4) Where within a period of thirty days referred to in sub-section (3), the registering authority does not refuse to grant the no objection certificate or does not communicate the refusal to the applicant, the registering authority shall be deemed to have granted the no objection certificate.

(5) Before granting or refusing to grant the no objection certificate, the registering authority shall obtain a report in writing from the police that no case relating to the theft of the motor vehicle concerned has been reported or is pending, verify whether all the amounts due to Government including road tax in respect of that motor vehicle have been paid and take into account such other factors as may be prescribed by the Central Government.

¹[(6) The owner of the vehicle shall also inform at the earliest, in writing, the registering authority about the theft of his vehicle together with the name of the police station where the theft report was lodged, and the registering authority shall take into account such report while disposing of any application for no objection certification, registration, transfer of ownership or issue of duplicate registration certificate].

49. Change of residence or place of business.

(1) If the owner of a motor vehicle ceases to reside or have his place of business at the address recorded in the certificate of registration of the vehicle, he shall, within thirty days of any such change of address, intimate in such form accompanied by such documents as may be prescribed by the Central Government, his new address, to the registering authority by which the certificate of registration was issued, or, if the new address is within the jurisdiction of another registering authority, to that other registering authority, and shall at the same time forward the certificate of registration to the registering authority or, as the case may be, to the other registering authority in order that the new address may be entered therein.

1. Ins. by Act 54 of 1994, sec. 13 (w.e.f. 14-11-1994).

(2) If the owner of a motor vehicle fails to intimate his new address to the concerned registering authority within the period specified in sub-section (1), the registering authority may, having regard to the circumstances of the case, require the owner to pay, in lieu of any action that may be taken against him under section 177, such amount not exceeding one hundred rupees as may be prescribed under sub-section (4):

Provided that action under section 177 shall be taken against the owner where he fails to pay the said amount.

(3) Where a person has paid the amount under sub-section (2), no action shall be taken against him under section 177.

(4) For the purposes of sub-section (2), a State Government may prescribe different amounts having regard to the period of delay in intimating his new address.

(5) On receipt of intimation under sub-section (1), the registering authority may, after making such verification as it may think fit, cause the new address to be entered in the certificate of registration.

(6) A registering authority other than the original registering authority making any such entry shall communicate the altered address to the original registering authority.

(7) Nothing in sub-section (1) shall apply where the change of the address recorded in the certificate of registration is due to a temporary absence not intended to exceed six months in duration or where the motor vehicle is neither used nor removed from the address recorded in the certificate of registration.

50. Transfer of ownership.

(1) Where the ownership of any motor vehicle registered under this Chapter is transferred,

(a) the transferor shall,-

(i) in the case of a vehicle registered within the same State, within fourteen days of the transfer, report the fact of transfer, in such form with such documents and in such manner, as may be prescribed by the Central Government to the registering authority within whose jurisdiction the transfer is to be effected and shall simultaneously send a copy of the said report to the transferee; and

(ii) in the case of a vehicle registered outside the State, within forty-five days of the transfer, forward to the registering authority referred to in sub-clause (i)-

(A) the no objection certificate obtained under section 48; or

(B) in a case where no such certificate has been obtained,-

(I) the receipt obtained under sub-section (2) of section 48; or

(II) the postal acknowledgment received by the transferee if he has sent an application in this behalf by registered post acknowledgment due to the registering authority referred to in section 48,

together with a declaration that he has not received any communication from such authority refusing to grant such certificate or requiring him to comply with any direction subject to which such certificate may be granted;

- (b) the transferee shall, within thirty days of the transfer, report the transfer to the registering authority within whose jurisdiction he has the residence or place of business where the vehicle is normally kept, as the case may be, and shall forward the certificate of registration to that registering authority together with the prescribed fee and a copy of the report received by him from the transferor in order that particulars of the transfer of ownership may be entered in the certificate of registration.

(2) Where-

- (a) the person in whose name a motor vehicle stands registered dies, or
- (b) a motor vehicle has been purchased or acquired at a public auction conducted by, or on behalf of, Government,

the person succeeding to the possession of the vehicle or, as the case may be, who has purchased or acquired the motor vehicle, shall make an application for the purpose of transferring the ownership of the vehicle in his name, to the registering authority in whose jurisdiction he has the residence or place of business where the vehicle is normally kept, as the case may be, in such manner, accompanied with such fee, and within such period as may be prescribed by the Central Government.

(3) If the transferor or the transferee fails to report to the registering authority the fact of transfer within the period specified in clause (a) or clause (b) of subsection (1), as the case may be, or if the person who is required to make an application under sub-section (2) (hereafter in this section referred to as the other person) fails to make such application within the period prescribed, the registering authority may, having regard to the circumstances of the case, require the transferor or the transferee, or the other person, as the case may be, to pay, in lieu of any action that may be taken against him under section 177 such amount not exceeding one hundred rupees as may be prescribed under subsection (5):

Provided that action under section 177 shall be taken against the transferor or the transferee or the other person, as the case may be, where he fails to pay the said amount.

(4) Where a person has paid the amount under sub-section (3), no action shall be taken against him under section 177.

(5) For the purposes of sub-section (3), a State Government may prescribe different amounts having regard to the period of delay on the part of the transferor or the transferee in reporting the fact of transfer of ownership of the motor vehicle or of the other person in making the application under sub-section (2).

(6) On receipt of a report under sub-section (1), or an application under subsection (2), the registering authority may cause the transfer of ownership to be entered in the certificate of registration.

(7) A registering authority making any such entry shall communicate the transfer of ownership to the transferor and to the original registering authority, if it is not the original registering authority.

51. Special provisions regarding motor vehicle subject to hire purchase agreement, etc.

(1) Where an application for registration of a motor vehicle which is held under a hire- purchase, lease or hypothecation agreement (hereafter in this section referred to as the said agreement) is made, the registering authority shall make an entry in the certificate of registration regarding the existence of the said agreement.

(2) Where the ownership of any motor vehicle registered under this Chapter is transferred and the transferee enters into the said agreement with any person, the ¹[last registering authority] shall, on receipt of an application in such form as the Central Government may prescribe from the parties to the said agreement, make an entry as to the existence of the said agreement in the certificate of registration ²[and an intimation in this regard shall be sent to the original registering authority if the last registering authority is not the original registering authority].

(3) Any entry made under sub-section (1) or sub-section (2), may be cancelled by the ¹[last registering authority] on proof of the termination of the said agreement by the parties concerned on an application being made in such form as the Central Government may prescribe ²[and an intimation in this behalf shall be sent to the original registering authority if the last registering authority is not the original registering authority].

(4) No entry regarding the transfer of ownership of any motor vehicle which is held under the said agreement shall be made in the certificate of registration except with the written consent of the person whose name has been specified in the certificate of registration as the person with whom the registered owner has entered into the said agreement.

(5) Where the person whose name has been specified in the certificate of registration as the person with whom the registered owner has entered into the said agreement, satisfies the registering authority that he has taken possession of the vehicle ³[from the registered owner] owing to the default of the registered owner under the provisions of the said agreement and that the registered owner refuses to deliver the certificate of registration or has absconded, such authority may, after giving the registered owner an opportunity to make such representation as he may wish to make (by sending to him a notice by registered post acknowledgment due at his address entered in the certificate of registration) and notwithstanding that the certificate of registration is not produced before it, cancel the certificate and issue a fresh certificate of registration in the name of the person with whom the registered owner has entered into the said agreement:

Provided that a fresh certificate of registration shall not be issued in respect of a motor vehicle, unless such person pays the prescribed fee:

Provided further that a fresh certificate of registration issued in respect of a motor vehicle, other than a transport vehicle, shall be valid only for the remaining period for which the certificate cancelled under this sub-section would have been in force.

1. Subs. by Act 54 of 1994, sec. 14, for "original registering authority" (w.e.f. 14-11-1994).

2. Added by Act 54 of 1994, sec. 14 (w.e.f. 14-11-1994).

3. Ins. by Act 54 of 1994, sec. 14 (w.e.f. 14-11-1994).

(6) The registered owner shall, before applying to the appropriate authority, for the renewal of a permit under section 81 or for the issue of duplicate certificate of registration under sub-section (14) of section 41, or for the assignment of a new registration mark ¹[under section 47, or removal of the vehicle to another State, or at the time of conversion of the vehicle from one class to another, or for issue of no objection certificate under section 48, or for change of residence or place of business under section 49, or for the alteration of the vehicle under section 52, make an application] to the person with whom the registered owner has entered into the said agreement, (such person being hereafter in this section referred to as the financier) for the issue of a no objection certificate (hereafter in this section referred to as the certificate).

Explanation.-For the purposes of this sub-section and sub-sections (8) and (9), "appropriate authority" in relation to any permit, means the authority which is authorised by this Act to renew such permit and, in relation to registration means the authority which is authorised by this Act to issue duplicate certificate of registration or to assign a new registration mark.

(7) Within seven days of the receipt of an application under sub-section (6) the financier may issue, or refuse, for reasons which shall be recorded in writing communicate to the applicant, to issue, the certificate applied for, and where the financier fails to issue the certificate and also fails to communicate the reasons for refusal to issue the certificate to the applicant within the said period of seven days, the certificate applied for shall be deemed to have been issued by the financier.

(8) The registered owner shall, while applying to the appropriate authority for the renewal of any permit under section 81, or for the issue of a duplicate certificate of registration under sub-section (14) of section 41, or while applying for assignment of a new registration mark under section 47, submit with such application the certificate, if any, obtained under sub-section (7) or, where no such certificate has been obtained, the communication received from the financier under that sub-section, or, as the case may be, a declaration that he has not received any communication from the financier within the period of seven days specified in that sub-section.

(9) On receipt of an application for the renewal of any permit or for the issue of duplicate certificate of registration or for assignment of a new registration mark in respect of a vehicle which is held under the said agreement, the appropriate authority may, subject to the other provisions of this Act,-

- (a) in a case where the financier has refused to issue the certificate applied for, after giving the applicant an opportunity of being heard, either-
 - (i) renew or refuse to renew the permit, or
 - (ii) issue or refuse to issue the duplicate certificate of registration, or
 - (iii) assign or refuse to assign a new registration mark;
- (b) in any other case,-
 - (i) renew the permit, or
 - (ii) issue duplicate certificate of registration, or
 - (iii) assign a new registration mark.

1. Subs. by Act 54 of 1994, sec. 14, for "under section 47, make an application" (w.e.f. 14-11-1994).

- (10) A registering authority making an entry in the certificate of registration regarding-
- (a) hire-purchase, lease or hypothecation agreement of a motor vehicle, or
 - (b) the cancellation under sub-section (3) of an entry, or
 - (c) recording transfer of ownership of motor vehicle, or
 - (d) any alteration in a motor vehicle, or
 - (e) suspension or cancellation of registration of a motor vehicle, or
 - (f) change of address,

shall communicate ¹[by registered post acknowledgment due] to the financier that such entry has been made.

²[(11) A registering authority registering the new vehicle, or issuing the duplicate certificate of registration or a no objection certificate or a temporary certificate of registration, or issuing or renewing, a fitness certificate or substituting entries relating to another motor vehicle in the permit, shall intimate the financier of such transaction.

(12) The registering authority where it is not the original registering authority, when making entry under sub-section (1) or sub-section (2), or cancelling the said entry under sub-section (3) or issuing the fresh certificate of registration under sub-section (5) shall communicate the same to the original registering authority.]

³**52. Alteration in motor vehicle.**

(1) No owner of a motor vehicle shall so alter the vehicle that the particulars contained in the certificate of registration are at variance with those originally specified by the manufacturer:

Provided that where the owner of a motor vehicle makes modification of the engine, or any part thereof, of a vehicle for facilitating its operation by different type of fuel or source of energy including battery, compressed natural gas, solar power, liquid petroleum gas or any other fuel or source of energy, by fitment of a conversion kit, such modification shall be carried out subject to such conditions as may be prescribed:

Provided further that the Central Government may prescribe specifications, conditions for approval, retrofitment and other related matters for such conversion kits:

Provided also that the Central Government may grant exemption for alteration of vehicles in a manner other than specified above, for any specific purpose.

(2) Notwithstanding anything contained in sub-section (1), a State Government may, by notification in the Official Gazette, authorise, subject to such conditions as may be specified in the notification, and permit any person owning not less than ten transport vehicles to alter any vehicle owned by him so as to replace the engine thereof with engine of the same make and type, without the approval of registering authority.

1. Ins. by Act 54 of 1994, sec. 14 (w.e.f. 14-11-1994).

2. Sub., by Act 54 of 1994, sec 14, for sub-section (11) (w.e.f. 14-11-1994).

3. Subs. by Act 27 of 2000, sec. 2, for section 52 (w.e.f. 11-8-2000).

(3) Where any alteration has been made in motor vehicle without the approval of registering authority or by reason of replacement of its engine without such approval under sub-section (2), the owner of the vehicle shall, within fourteen days of the making of the alteration, report the alteration to the registering authority within whose jurisdiction he resides and shall forward the certificate of registration to that authority together with the prescribed fee in order that particulars of registration may be entered therein.

(4) A registering authority other than the original registering authority making any such entry shall communicate the details of the entry to the original registering authority.

(5) Subject to the provisions made under sub-sections (1), (2), (3) and (4), no person holding a vehicle under a hire-purchase agreement shall make any alteration to the vehicle except with the written consent of the registered owner.

Explanation:-For the purposes of this section, "alteration" means a change in the structure of a vehicle which results in a change in its basic feature.].

53. Suspension of registration.

(1) If any registering authority or other prescribed authority has reason to believe that any motor vehicle within its jurisdiction-

- (a) is in such a condition that its use in a public place would constitute a danger to the public, or that it fails to comply with the requirements of this Act or of the rules made thereunder, or
- (b) has been, or is being, used for hire or reward without a valid permit for being used as such,

the authority may, after giving the owner an opportunity of making any representation he may wish to make (by sending to the owner a notice by registered post acknowledgment due at his address entered in the certificate of registration), for reasons to be recorded in writing, suspend the certificate of registration of the vehicle-

- (i) in any case falling under clause (a), until the defects are rectified to its satisfaction; and
- (ii) in any case falling under clause (b), for a period not exceeding four months.

(2) An authority other than a registering authority shall when making a suspension order under sub-section (1), intimate in writing the fact of such suspension and the reasons therefor to the registering authority within whose jurisdiction the vehicle is at the time of the suspension.

(3) Where the registration of a motor vehicle has been suspended under subsection (1) for a continuous period of not less than one month, the registering authority, within whose jurisdiction the vehicle was when the registration was suspended, shall, if it is not the original registering authority, inform that authority of the suspension.

- (4) The owner of a motor vehicle shall, on the demand of a registering authority or other prescribed authority which has suspended the certificate of registration of the vehicle under this section, surrender the certificate of registration.
- (5) A certificate of registration surrendered under sub-section (4) shall be returned to the owner when the order suspending registration has been rescinded and not before.

54. Cancellation of registration suspended under section 53.

When the suspension of registration of a vehicle under section 53 has continued without interruption for a period of not less than six months, the registering authority within whose jurisdiction the vehicle was when the registration was suspended, may, if it is the original registering authority, cancel the registration, and if it is not the original registering authority, shall forward the certificate of registration to that authority which may cancel the registration.

55. Cancellation of registration.

- (1) If a motor vehicle has been destroyed or has been rendered permanently incapable of use, the owner shall, within fourteen days or as soon as may be, report the fact to the registering authority within whose jurisdiction he has the residence or place of business where the vehicle is normally kept, as the case may be, and shall forward to the authority the certificate of registration of the vehicle.
- (2) The registering authority shall, if it is the original registering authority, cancel the registration and the certificate of registration, or, if it is not, shall forward the report and the certificate of registration to the original registering authority and that authority shall cancel the registration.
- (3) Any registering authority may order the examination of a motor vehicle within its jurisdiction by such authority as the State Government may by order appoint and, if upon such examination and after giving the owner an opportunity to make any representation he may wish to make (by sending to the owner a notice by registered post acknowledgment due at his address entered in the certificate of registration), it is satisfied that the vehicle is in such a condition that it is incapable of being used or its use in a public place would constitute a danger to the public and that it is beyond reasonable repair, may cancel the registration.
- (4) If a registering authority is satisfied that a motor vehicle has been permanently removed out of India, the registering authority shall cancel the registration.
- (5) If a registering authority is satisfied that the registration of a motor vehicle has been obtained on the basis of documents which were, or by representation of facts which was, false in any material particular, or the engine number or the chassis number embossed thereon are different from such number entered in the certificate of registration, the registering authority shall after giving the owner an opportunity to make such representation as he may wish to make (by sending to the owner a notice by registered post acknowledgment due at his address entered in the certificate of registration), and for reasons to be recorded in writing, cancel the registration.

(6) A registering authority cancelling the registration of a motor vehicle under section 54 or under this section shall communicate such fact in writing to the owner of the vehicle, and the owner of the vehicle shall forthwith surrender to that authority the certificate of registration of the vehicle.

(7) A registering authority making an order of cancellation under section 54 or under this section shall, if it is the original registering authority, cancel the certificate of registration and the entry relating to the vehicle in its records, and, if it is not the original registering authority, forward the certificate of registration to that authority, and that authority shall cancel the certificate of registration and the entry relating to the motor vehicle in its records.

(8) The expression "original registering authority" in this section and in sections 41,49, 50,52, 53 and 54 means the registering authority in whose records the registration of the vehicle is recorded.

(9) In this section "certificate of registration" includes a certificate of registration renewed under the provisions of this Act.

56. Certificate of fitness of transport vehicles.

(1) Subject to the provisions of sections 59 and 60, a transport vehicle shall not be deemed to be validly registered for the purposes of section 39, unless it carries a certificate of fitness in such form containing such particulars and information as may be prescribed by the Central Government, issued by the prescribed authority, or by an authorized testing station mentioned in sub-section (2), to the effect that the vehicle complies for the time being with all the requirements of this Act and the rules made thereunder:

Provided that where the prescribed authority or the "authorized testing station" refuses to issue such certificate, it shall supply the owner of the vehicle with its reasons in writing for such refusal.

(2) The "authorized testing station" referred to in sub-section (1) means a vehicle service station or public or private garage which the State Government, having regard to the experience, training and ability of the operator of such station or garage and the testing equipment and the testing personnel therein, may specify in accordance with the rules made by the Central Government for regulation and control of such stations or garages.

(3) Subject to the provisions of sub-section (4), certificate of fitness shall remain effective for such period as may be prescribed by the Central Government having regard to the objects of this Act.

(4) The prescribed authority may for reasons to be recorded in writing cancel a certificate of fitness at any time, if satisfied that the vehicle to which it relates no longer complies with all the requirements of this Act and the rules made thereunder; and on such cancellation the certificate of registration of the vehicle and any permit granted in respect of the vehicle under Chapter V shall be deemed to be suspended until a new certificate of fitness has been obtained:
¹[Provided that no such cancellation shall be made by the prescribed authority unless such prescribed authority holds such technical qualification as may be prescribed or where the prescribed authority does not hold such technical qualification on the basis of the report of an officer having such qualifications.]

1. Ins. by Act 54 of 1994, sec. 16 (w.e.f. 14-11-1994).

(5) A certificate of fitness issued under this Act shall, while it remains effective be valid throughout India.

57. Appeals.

¹[(1) Any person aggrieved by an order of the registering I authority under section 41, 42, 43, 45, 47, 48, 49, 50, 52, 53, 55 or 56 may, within thirty days of the date on which he has received notice of such order, appeal against the order to the prescribed authority.]

(2) The appellate authority shall give notice of the appeal to the original authority and after giving an opportunity to the original authority and the appellant to be heard in the appeal pass such order as it thinks fit.

58. Special provisions in regard to transport vehicles.

(1) The Central Government may, having regard to the number, nature and size of the tyres attached to the wheels of a transport vehicle (other than a motor cab), and its make and model and other relevant considerations, by notification in the Official Gazette, specify, in relation to each make and model of a transport vehicle, the ²[maximum gross vehicle weight] of such vehicle and the maximum safe axle weight of each axle of such vehicle.

(2) A registering authority, when registering a transport vehicle, other than a motor cab, shall enter in the record of registration and shall also enter in the certificate of registration of the vehicle the following particulars, namely:-

- (a) the unladen weight of the vehicle;
- (b) the number, nature and size of the tyres attached to each wheel;
- (c) the gross vehicle weight of the vehicle and the registered axle weights pertaining to the several axles thereof; and
- (d) if the vehicle is used or adapted to be used for the carriage of passengers solely or in addition to goods, the number of passengers for whom accommodation is provided,

and the owner of the vehicle shall have the same particulars exhibited in the prescribed manner on the vehicle.

(3) There shall not be entered in the certificate of registration of any such vehicle any gross vehicle weight or a registered axle weight of any of the axles different from that specified in the notification under sub-section (1) in relation to the make and model of such vehicle and to the number, nature and size of the tyres attached to its wheels:

Provided that where it appears to the Central Government that heavier weights than those specified in the notification under sub-section (1) may be permitted in a particular locality for vehicles of a particular type, the Central Government may, by order in the Official Gazette direct that the provisions of this sub-section shall apply with such modifications as may be specified in the order.

³[***]

1.Subs, by Act 54 of 1994, sec. 17, for sub-section (1) (w.e.f. 14-11-1994).

2. Subs. by act 54 of 1994, sec. 18. for "maximum safe laden weight" (w.e.f. 14-11-1994).

3. Sub-section (4) omitted by Act 27 of 2000, sec. 3 (w.e.f. 11-8-2000).

(5) In order that the gross vehicle weight entered in the certificate of registration of a vehicle may be revised in accordance with the provisions of subsection (3), the registering authority may require the owner of transport vehicle in accordance with such procedure as may be prescribed to produce the certificate of registration within such time as may be specified by the registering authority.

59. Power to fix the age limit of motor vehicle.

(1) The Central Government may, having regard to the public safety, convenience and objects of this Act, by notification in the Official Gazette, specify the life of a motor vehicle reckoned from the date of its manufacture, after the expiry of which the motor vehicle shall not be deemed to comply with the requirements of this Act and the rules made thereunder:

Provided that the Central Government may specify different ages for different classes or different types of motor vehicles.

(2) Notwithstanding anything contained in sub-section (1), the Central Government may, having regard to the purpose of a motor vehicle, such as, display or use for the purposes of a demonstration in any exhibition, use for the purposes of technical research or taking part in a vintage car rally, by notification in the Official Gazette, exempt, by a general or special order, subject to such conditions as may be specified in such notification, any class or type of motor vehicle from the operation of sub-section (1) for the purpose to be stated in the notification.

(3) Notwithstanding anything contained in section 56, no prescribed authority or authorized testing station shall grant a certificate of fitness to a motor vehicle in contravention of the provisions of any notification issued under sub-section (1).

60. Registration of vehicles belonging to the Central Government.

(1) Such authority as the Central Government may, by notification in the Official Gazette, specify, may register any motor vehicle which is the property or for the time being under the exclusive control of the Central Government and is used for Government purposes relating to the defence of the country and unconnected with any commercial enterprise and any vehicle so registered shall not, so long as it remains the property or under the exclusive control of the Central Government, require to be registered otherwise under this Act.

(2) The authority registering a vehicle under sub-section (1) shall assign a registration mark in accordance with the provisions contained in the rules made in this behalf by the Central Government and shall issue a certificate in respect of that vehicle to the effect that such vehicle complies for the time being with all the requirements of this Act and the rules made thereunder and that the vehicle has been registered under this section.

(3) A vehicle registered under this section shall carry the certificate issued under sub-section (2).

(4) If a vehicle registered under this section ceases to be the property or under the exclusive control of the Central Government, the provisions of sections 39 and 40 shall thereupon apply.

(5) The authority registering a vehicle under sub-section (1) shall furnish to any State Government all such information regarding the general nature, overall dimensions and axle weights of the vehicle as the State Government may at any time require.

61. Application of Chapter to trailers.

(1) The provisions of this Chapter shall apply to the registration of trailers as they apply to the registration of any other motor vehicle.

(2) The registration mark assigned to a trailer shall be displayed in such manner on the side of the drawing vehicle as may be prescribed by the Central Government.

(3) No person shall drive a motor vehicle to which a trailer is or trailers are attached unless the registration mark of the motor vehicle so driven is displayed on the trailer or on the last trailer in the train, as the case may be, in such manner as may be prescribed by the Central Government

62. Information regarding stolen and recovered motor vehicles to be furnished by the police to the State Transport Authority.

The State Government may, if it thinks necessary or expedient so to do in the public interest, direct the submission by the Inspector General of Police (by whatever designation called) and such other police officers as the State Government may specify in this behalf, of such returns containing the information regarding vehicles which have been stolen and stolen vehicles which have been recovered of which the police are aware, to the State Transport Authority, and may prescribe the form in which and the period within which such returns shall be made.

63. Maintenance of State Registers of Motor Vehicles.

(1) Each State Government shall maintain in such form as may be prescribed by the Central Government a register to be known as the State Register of Motor Vehicles, in respect of the motor vehicles in that State, containing the following particulars, namely:-

- (a) registration numbers;
- (b) years of manufacture;
- (c) classes and types;
- (d) names and addresses of registered owners; and
- (e) such other particulars as may be prescribed by the Central Government.

(2) Each State Government shall supply to the Central Government ¹[if so desired by it] a printed copy of the State Register of Motor Vehicles and shall also inform the Central Government without delay of all additions to and other amendments in such register made from time to time.

1. Ins. by Act 54 of 1994, sec. 19 (w.e.f. 14-11-1994).

(3) The State Register of Motor Vehicles shall be maintained in such manner as may be prescribed by the State Government.

64. Power of Central Government to make rules.

The Central Government may make rules to provide for all or any of the following matters, namely:-

- (a) the period within which and the form in which an application shall be made and the documents, particulars and information it shall accompany under sub-section (1) of section 41;
- (b) the form in which the certificate of registration shall be made and the particulars and information it shall contain and the manner in which it shall be issued under sub-section (3) of section 41;
- (c) the form and manner in which the particulars of the certificate of registration shall be entered in the records of the registering authority under sub-section (5) of section 41;
- (d) the manner in which and the form in which the registration mark, the letters and figures and other particulars referred to in sub-section (6) of section 41 shall be displayed and shown;
- (e) the period within which and the form in which the application shall be made and the particulars and information it shall contain under sub-section (8) of section 41;
- (f) the form in which the application referred to in sub-section (14) of section 41 shall be made, the particulars and information it shall contain and the fee to be charged;
- (g) the form in which and the period within which the application referred to in sub-section (1) of section 47 shall be made and the particulars it shall contain;
- (h) the form in which and the manner in which the application for "No Objection Certificate" shall be made under sub-section (1) of section 48 and the form of receipt to be issued under sub-section (2) of section 48;
- (i) the matters that are to be complied with by an applicant before no objection certificate may be issued under section 48;
- (j) the form in which the intimation of change of address shall be made under sub-section (1) of section 49 and the documents to be submitted along with the application;

- (k) the form in which and the manner in which the intimation of transfer of ownership shall be made under sub-section (1) of section 50 or under sub-section (2) of section 50 and the document to be submitted along with the application;
- (l) the form in which the application under sub-section (2) or subsection (3) of section 51 shall be made;
- (m) the form in which the certificate of fitness shall be issued under subsection (1) of section 56 and the particulars and information it shall contain;
- (n) the period for which the certificate of fitness granted or renewed under section 56 shall be effective;
- (o) the fees to be charged for the issue or renewal or alteration of certificates of registration, for making an entry regarding transfer of ownership on a certificate of registration, for making or cancelling an endorsement in respect of agreement of hire-purchase or lease or hypothecation on a certificate of registration, for certificates of fitness for registration marks, and for the examination or inspection of motor vehicles, and the refund of such fees,
- (p) any other matter which is to be, or may be, prescribed by the Central Government.

65. Power of State Government to make rules

- (1) A State Government may make rules for the purpose of carrying into effect the provisions of this Chapter other than the matters specified in section 64.
- (2) Without prejudice to the generality of the foregoing power, such rules may provide for-
 - (a) the conduct and hearing of appeals that may be preferred under this Chapter (the fees to be paid in respect of such appeals and the refund of such fees);
 - (b) the appointment, functions and jurisdiction of registering and other prescribed authorities;
 - (c) the exemption of road-rollers, graders and other vehicles designed and used solely for the construction, repair and cleaning of roads from all or any of the provisions of this Chapter and the rules made thereunder and the conditions governing such exemption;
 - (d) the issue or renewal of certificates of registration and fitness and duplicates of such certificates to replace the certificates lost, destroyed or mutilated;
 - (e) the production of certificates of registration before the registering authority for the revision of entries therein of particulars relating the gross vehicle weight;
 - (f) the temporary registration of motor vehicles and the issue temporary certificate of registration and marks;

- (g) the manner in which the particulars referred to in sub-section (2) section 58 and other prescribed particulars shall be exhibited;
- (h) the exemption of prescribed persons or prescribed classes of persons from payment of all or any portion of the fees payable under this Chapter;
- (i) the forms, other than those prescribed by the Central Government, to be used for the purpose of this Chapter;
- (j) the communication between registering authorities of particulars of certificates of registration and by owners of vehicles registered outside the State of particulars of such vehicles and of their registration;
- (k) the amount or amounts under sub-section (13) of section 41 or sub-section (7) of section 47 or sub-section (4) of section 49 or sub-section (5) of section 50;
- (l) the extension of the validity of certificates of fitness pending consideration of applications for their renewal;
- (m) the exemption from the provisions of this Chapter and the conditions and fees for exemption, of motor vehicles in the possession of dealers;
- (n) the form in which and the period within which the return under section 62 shall be sent;
- (o) the manner in which the State Register of Motor Vehicles shall be maintained under section 63;
- (p) any other matter which is to be or may be prescribed.

**CHAPTER V
CONTROL OF TRANSPORT VEHICLES**

66. Necessity for permits.

(1) No owner of a motor vehicle shall use or permit the use of the vehicle as a transport vehicle in any public place whether or not such vehicle is actually carrying any passengers or goods save in accordance with the conditions of a permit granted or countersigned by a Regional or State Transport Authority or any prescribed authority authorising him the use of the vehicle in that place in the manner in which the vehicle is being used:

Provided that a stage carriage permit shall, subject to any conditions that may be specified in the permit, authorise the use of the vehicle as a contact carriage:

Provided further that a stage carriage permit may, subject to any conditions that may be specified in the permit, authorise the use of the vehicle as a goods carriage either when carrying passengers or not:

Provided also that a goods carriage permit shall, subject to any conditions that may be specified in the permit, authorise the holder to use the vehicle for the carriage of goods for or in connection with a trade or business carried on by him.

(2) The holder of a goods carriage permit may use the vehicle, for the drawing of any trailer or semi-trailer not owned by him, subject to such conditions as may be prescribed:

¹[Provided that the holder of a permit of any articulated vehicle may use the prime-mover of that articulated vehicle for any other semi-trailor.]

(3) The provisions of sub-section (1) shall not apply-

- (a) to any transport vehicle owned by the Central Government or a State Government and used for Government purposes unconnected with any commercial enterprise;
- (b) to any transport vehicle owned by a local authority or by a person acting under contract with a local authority and used solely for road cleaning, road watering or conservancy purposes;
- (c) to any transport vehicle used solely for police, fire brigade or ambulance purposes;
- (d) to any transport vehicle used solely for the conveyance of corpses and the mourners accompanying the corpses;
- (e) to any transport vehicle used for towing a disabled vehicle or for removing goods from a disabled vehicle to a place of safety;
- (f) to any transport vehicle used for any other public purpose as may be prescribed by the State Government in this behalf;

1. Added by Act 54 of 1994, sec. 20 (w.e.f. 14-11-1994).

- (g) to any transport vehicle used by a person who manufactures or deals in motor vehicles or builds bodies for attachment to chassis, solely for such purposes and in accordance with such conditions as the Central Government may, by notification in the Official Gazette, specify in this behalf;

¹[***]

- (i) to any goods vehicle, the gross vehicle weight of which does not exceed 3,000 kilograms;
- (j) subject to such conditions as the Central Government may, by notification in the Official Gazette, specify, to any transport vehicle purchased in one State and proceeding to a place, situated in that State or in any other State, without carrying any passenger or goods;
- (k) to any transport vehicle which has been temporarily registered under section 43 while proceeding empty to any place for the purpose of registration of the vehicle;

²[***]

- (m) to any transport vehicle which, owing to flood, earthquake or any other natural calamity, obstruction on road, or unforeseen circumstances, is required to be diverted through any other route, whether within or outside the State, with a view to enabling it to reach its destination;
- (n) to any transport vehicle used for such purposes as the Central or State Government may, by order, specify;
- (o) to any transport vehicle which is subject to a hire-purchase, lease or hypothecation agreement and which owing to the default of the owner has been taken possession of by or on behalf of the person with whom the owner has entered into such agreement, to enable such motor vehicle to reach its destination; or
- (p) to any transport vehicle while proceeding empty to any place for purpose of repair.
- (4) Subject to the provisions of sub-section (3), sub-section (1) shall, if the State Government by rule made under section 96 so prescribes, apply to any motor vehicle adapted to carry more than nine persons excluding the driver.

1. Clause (h) omitted by Act 27 of 2000, sec. 4 (w.e.f. 11-8-2000).

2. Clause (l) subs, by Act 54 of 1994, sec. 20 (w.e.f. 14-11-1994) and omitted by Act 39 of 2001, sec. 2 27-9-2001).

67. Power to State Government to control road transport.

- (1) A State Government, having regard to-
- (a) the advantages offered to the public, trade and industry by the development of motor transport,
 - (b) the desirability of co-ordinating road and rail transport,
 - (c) the desirability of preventing the deterioration of the road system and
 - (d) the desirability of preventing uneconomic competition among holders of permits. may, from time to time, by notification in the Official Gazette, issue directions both to the State Transport Authority and Regional Transport Authority-
 - (i) regarding the fixing of fares and freights (including the maximum and minimum in respect thereof) for stage carriages, contract carriages and goods carriages:

¹[***]

- (ii) regarding the prohibition or restriction, subject to such conditions as may be specified in the directions, of the conveying of long distance goods traffic generally, or of specified classes of goods by goods carriages;
- (iii) regarding any other matter which may appear to the State Government necessary or expedient for giving effect to any agreement entered into with the Central Government or any other State Government or the Government of any other country relating to the regulation of motor transport generally, and in particular to its coordination with other means of transport and the conveying of long distance goods traffic:

Provided that no such notification in respect of the matter: referred to in clause (ii) or clause (iii) shall be issued unless a draft of the proposed directions is published in the Official Gazette specifying therein a date being not less than one month after such publication, on or after which the draft will be taken into consideration and any objection or suggestion which may be received has, in consultation with the State Transport Authority, been considered after giving the representatives of the interests affected an opportunity of being heard.

- (2) Any direction under sub-section (1) regarding the fixing of fares and freights for stage carriages, contract carriages and goods carriages may provide that such fares or freights shall be inclusive of the tax payable by the passengers or the consignors of the goods, as the case may be, to the operators of the stage carriages, contract carriages or goods carriages under any law for the time being in force relating to tax on passengers and goods.

1. Proviso ins. by Act 54 of 1994, sec. 21 (w.e.f. 14-11-1994) and omitted by Act 39 of 2001 sec. 3 27-9-2001).

68. Transport Authorities

(1) The State Government shall by notification in the Official Gazette, constitute for the State a State Transport Authority to exercise and discharge the powers and functions specified in sub-section (3), and shall in like manner constitute Regional Transport Authorities to exercise and discharge throughout such areas (in this Chapter referred to as regions) as may be specified in the notification in respect of each Regional Transport Authority; the powers and functions conferred by or under this Chapter on such Authorities:

Provided that in the Union Territories, the Administrator may abstain from constituting any Regional Transport Authority.

(2) A State Transport Authority or a Regional Transport Authority shall consist of a Chairman who has had judicial experience or experience as an appellate or a revisional authority or as an adjudicating authority competent to pass any order or take any decision under any law and in the case of a State Transport Authority, such other persons (whether officials or not), not being more than four and, in the case of a Regional Transport Authority, such other persons (whether officials or not), not being more than two, as the State Government may think fit to appoint; but no person who has any financial interest whether as proprietor, employee or otherwise in any transport undertaking shall be appointed, or continue to be, a member of a State or Regional Transport Authority, and, if any person being a member of a any such Authority acquires a financial interest in any transport undertaking, he shall within four weeks of so doing, give notice in writing to the State Government of the acquisition of such interest and shall vacate office:

Provided that nothing in this sub-section shall prevent any of the members of the State Transport Authority or a Regional Transport Authority, as the case may be, to preside over a meeting of such Authority during the absence of the Chairman, notwithstanding that such member does not possess judicial experience or experience as an appellate or a revisional authority or as an adjudicating authority competent to pass any order or take any decision under any law:

Provided further that the State Government may,-

- (i) where it considers necessary or expedient so to do, constitute the State Transport Authority or a Regional Transport Authority for any region so as to consist of only one member who shall be an official with judicial experience or experience as an appellate or a revisional authority or as an adjudicating authority competent to pass any order or take any decision under any law;
- (ii) by rules made in this behalf, provide for the transaction of business of such authorities in the absence of the Chairman of any other member and specify the circumstances under which, and the manner in which, such business could be so transacted:

Provided also that nothing in this sub-section shall be construed as debarring an official (other than an official connected directly with the management or operation of a transport undertaking) from being appointed or continuing as a member of any such authority merely by reason of the fact that the Government employing the official has, or acquires, any financial interest in a transport undertaking.

(3) The State Transport Authority and every Regional Transport Authority shall give effect to any directions issued under section 67 and the State Transport Authority shall, subject to such directions and save as otherwise provided by or under this Act, exercise and discharge throughout the State the following power and functions, namely:-

- (a) to coordinate and regulate the activities and policies of the Regional Transport Authorities, if any, of the State;
- (b) to perform the duties of a Regional Transport Authority where there is no such Authority and, if it thinks fit or if so required by a Regional Transport Authority, to perform those duties in respect of any route common to two or more regions;
- (c) to settle all disputes and decide all matters on which differences of opinion arise between Regional Transport Authorities; and

¹[(ca) Government to formulate routes for plying stage carriages; and]

- (d) to discharge such other functions as may be prescribed.

(4) For the purpose of exercising and discharging the powers and functions specified in sub-section (3), a State Transport Authority may, subject to such conditions as may be prescribed, issue directions to any Regional Transport Authority, and the Regional Transport Authority shall, in the discharge of its functions under this Act, give effect to and be guided by such directions.

(5) The State Transport Authority and any Regional Transport Authority, if authorised in this behalf by rules made under section 96, may delegate such of its powers and functions to such authority or person subject to such restrictions, limitations and conditions as may be prescribed by the said rules.

69. General provision as to applications for permits.

(1) Every application for a permit shall be made to the Regional Transport Authority of the region in which it is proposed to use the vehicle or vehicles:

Provided that if it is proposed to use the vehicle or vehicles in two or more regions lying within the same State, the application shall be made to the Regional Transport Authority of the region in which the major portion of the proposed route or area lies, and in case the portion of the proposed route or area in each of the regions is approximately equal, to the Regional Transport Authority of the region in which it is proposed to keep the vehicle or vehicles:

Provided further that if it is proposed to use the vehicle or vehicles in two or more regions lying in different States, the application shall be made to the Regional Transport Authority of the region in which the applicant resides or has his principal place of business.

(2) Notwithstanding anything contained in sub-section (1), the State Government may, by notification in the Official Gazette, direct that in the case of any vehicle or vehicles proposed to be used in two or more regions lying in different States, the application under that sub-section shall be made to the State Transport Authority of the region in which the applicant resides or has his principal place of business.

1. Ins. by Act 54 of 1994, sec. 22 (w.e.f. 14-11-1994).

70. Application for stage carriage permit.

(1) An application for a permit in respect of a stage carriage (in this Chapter referred to as a stage carriage permit) or as a reserve stage carriage shall, as far as may be, contain the following particulars, namely:-

- (a) the route or routes or the area or areas to which the application relates;
- (b) the type and seating capacity of each such vehicle;
- (c) the minimum and maximum number of daily trips proposed to be provided and the time-table of the normal trips.

Explanation.-For the purposes of this section, section 72, section 80 and section 102, "trip" means a single journey from one point to another, and every return journey shall be deemed to be a separate trip;

- (d) the number of vehicles intended to be kept in reserve to maintain the service and to provide for special occasions;
- (e) the arrangements intended to be made for the housing, maintenance and repair of the vehicles, for the comfort and convenience of passengers and for the storage and safe custody of luggage;
- (f) such other matters as may be prescribed.

(2) An application referred to in sub-section (1) shall be accompanied by such documents as may be prescribed.

71. Procedure of Regional Transport Authority in considering application for stage carriage permit.

(1) A Regional Transport Authority shall, while considering an application for a stage carriage permit, have regard to the objects of this Act.

¹[***]

(2) A Regional Transport Authority shall refuse to grant a stage carriage permit if it appears from any time-table furnished that the provisions of this Act relating to the speed at which vehicles may be driven are likely to be contravened:

Provided that before such refusal an opportunity shall be given to the applicant to amend the time-table so as to conform to the said provisions.

(3) (a) The State Government shall, if so directed by the Central Government having regard to the number of vehicles, road conditions and other relevant matters, by notification in the Official Gazette, direct a State Transport Authority and a Regional Transport Authority to limit the number of stage carriage; generally or of any specified type, as may be fixed and specified in the notification, operating on city routes in towns with a population of not less than five lakhs.

1. Proviso omitted by Act 54 of 1994, sec. 23 (w.e.f. 14-11-1994).

- (b) Where the number of stage carriages are fixed under clause (a), the Government of the State shall reserve in the State certain percentage of stage carriage permits for the scheduled castes and the scheduled tribes in the same ratio as in the case of appointments made by direct recruitment to public services in the State.
- (c) Where the number of stage carriages are fixed under clause (a), the Regional Transport Authority shall reserve such number of permits for the scheduled castes and the scheduled tribes as may be fixed by the State Government under sub-clause (b).
- (d) After reserving such number of permits as is referred to in clause (c), the Regional Transport Authority shall in considering an application have regard to the following matters, namely:-
- (i) financial stability of the applicant;
 - (ii) satisfactory performance as a stage carriage operator including payment of tax if the applicant is or has been an operator of stage carriage service; and
 - (iii) such other matters as may be prescribed by the State Government:

Provided that, other conditions being equal, preference shall be given to applications for permits from-

- (i) State transport undertakings;
- (ii) co-operative societies registered or deemed to have been registered under any enactment for the time being in force; ¹[***]
- (iii) ex-servicemen; ²[or]
- ³[(iv) any other class or category of persons, as the State Government may, for reasons to be recorded in writing, consider necessary.]

³[***]

Explanation.-For the purposes of this section "company" means any body corporate, and includes a firm or other association of individuals; and "director", in relation to a firm, means a partner in the firm.

72. Grant of stage carriage permit-

- (1) Subject to the provisions of section 71, a Regional Transport Authority may, on an application made to it under section 70, grant a stage carriage permit in accordance with the application or with such modification as it deems fit or refuse to grant such a permit.

1. Word "or" omitted by Act 54 of 1994, sec. 23 (w.e.f. 14-11-1994).

2. Ins. by Act 54 of 1994, sec. 23 (w.e.f. 14-11-1994).

3. Sub-sections (4) and (5) omitted by Act 54 of 1994, sec. 23 (w.e.f. 14-11-1994).

Provided that no such permit shall be granted in respect of any route or area not specified in the application.

(2) The Regional Transport Authority, if it decides to grant a stage carriage permit, may grant the permit for a stage carriage of a specified description and may, subject to any rules that may be made under this Act, attach to the permit any one or more of the following conditions, namely-

- (i) that the vehicles shall be used only in a specified area, or on a specified route or routes;
- (ii) that the operation of the stage carriage shall be commenced with effect from a specified date;
- (iii) the minimum and maximum number of daily trips to be provided in relation to any route or area generally or on specified days and occasions;
- (iv) that copies of the time-table of the stage carriage approved by the Regional Transport Authority shall be exhibited on the vehicle and at specified stands and halts on the route or within the area;
- (v) that the stage carriage shall be operated within such margins of deviation from the approved time-table as the Regional Transport Authority may from time to time specify;
- (vi) that within municipal limits and such other areas and places as may be prescribed, passengers or goods shall not be taken up or set down except at specified points;
- (vii) the maximum number of passengers and the maximum weight of luggage that may be carried on the stage carriage, either generally or on specified occasion or at specified times and seasons;
- (viii) the weight and nature of passengers luggage that shall be carried free of charge, the total weight of luggage that may be carried in relation to each passenger, and the arrangements that shall be made for the carriage of luggage without causing inconvenience to passengers;
- (ix) the rate of charge that may be levied for passengers' luggage in excess of the free allowance;
- (x) that vehicles of specified type fitted with body conforming to approved specifications shall be used.

Provided that the attachment of this condition to a permit shall not prevent the continued use, for a period of two years from the date of publication of the approved specifications, of any vehicle operating on that date;

- (xi) that specified standards of comfort and cleanliness shall be maintained in the vehicles;

- (xii) the conditions subject to which goods may be carried in the stage carriage in addition to or to the exclusion of passengers;
- (xiii) that specified shall be charged in accordance with the approved fare table;
- (xiv) that a copy of or extract from the fare table approved by the Regional Transport Authority and particulars of any special fares or rates of fares so approved for particular occasions shall be exhibited on the stage carriage and at specified stands and halts;
- (xv) that tickets bearing specified particulars shall be issued to passengers and shall show the fares actually charged and that records of tickets issued shall be kept in a specified manner;
- (xvi) that mails shall be carried on the vehicle subject to such conditions (including conditions as to the time in which mails are to be carried and the charge which may be levied) as may be specified;
- (xvii) the vehicles to be kept as reserve by the holder of the permit to maintain the operation and to provide for special occasions;
- (xviii) the conditions subject to which vehicle may be used as a contract carriage;
- (xix) that specified arrangements shall be made for the housing, maintenance and repair of vehicle;
- (xx) that any specified bus station or shelter maintained by Government or a local authority shall be used and any specified rent or fee shall be paid for such use;
- (xxi) that the conditions of the permit shall not be departed from, save with the approval of the Regional Transport Authority;
- (xxii) that the Regional Transport Authority may, after giving notice of not less than one month,-
 - (a) vary the conditions of the permit;
 - (b) attach to the permit further conditions.

Provided that the conditions specified in pursuance of clause (i) shall not be varied so as to alter the distance covered by the original route by more than 24 kilometers, and any variation within such limits shall be made only after the Regional Transport Authority is satisfied that such variation will serve the convenience of the public and that it is not expedient to grant a separate permit in respect of the original route as so varied or any part thereof;

- (xxiii) that the holder of a permit shall furnish to the Regional Transport Authority such periodical returns, statistics and other information as the State Government may from time to time prescribe;
- (xxiv) any other conditions which may be prescribed

73. Application for contract carriage permit-

An application for a permit in respect of a contract carriage (in this Chapter referred to as a contract carriage permit) shall contain the following particulars, namely-

- (a) the type and seating capacity of the vehicle;
- (b) the area for which the permit is required;
- (c) any other particulars which may be prescribed.

74. Grant of contract carriage permit.

(1) Subject to the provisions of subsection (3), a Regional Transport Authority may, on an application made to it under section 73, grant a contract carriage permit in accordance with the application or with such modifications as it deems fit or refuse to grant such a permit:

Provided that no such permit shall be granted in respect of any area not specified in the application.

(2) The Regional Transport Authority, if it decides to grant a contract carriage permit, may, subject to any rules that may be made under this Act, attach to the permit any one or more of the following conditions, namely:-

- (i) that the vehicles shall be used only in a specified area or on a specified route or routes;
- (ii) that except in accordance with specified conditions, no contract of hiring, other than an extension or modification of a subsisting contract, may be entered into outside the specified area;
- (iii) the maximum number of passengers and the maximum weight of luggage that may be carried on the vehicles, either generally or on specified occasions or at specified times and seasons;
- (iv) the conditions subject to which goods may be carried in any contract carriage in addition to, or to the exclusion of, passengers;
- (v) that, in the case of motorcabs, specified fares or rates of fares shall be charged and a copy of the fare table shall be exhibited on the vehicle;
- (vi) that, in the case of vehicles other than motorcabs, specified rates of hiring not exceeding specified maximum shall be charged;
- (vii) that in the case of motorcabs, a specified weight of passengers' luggage shall be carried free of charge, and that the charge, if any, for any luggage in excess thereof shall be at a specified rate;
- (viii) that, in the case of motorcabs, a taximeter shall be fitted and maintained in proper working order, if prescribed;

- (ix) that the Regional Transport Authority may, after giving notice of not less than one month,-
 - (a) vary the conditions of the permit;
 - (b) attach to the permit further conditions;
 - (x) that the conditions of permit shall not be departed from save with the approval of the Regional Transport Authority;
 - (xi) that specified standards of comfort and cleanliness shall be maintained in the vehicles;
 - (xii) that, except in the circumstances of exceptional nature, the plying of the vehicle or carrying of the passengers shall not be refused;
 - (xiii) any other conditions which may be prescribed.
- (3) (a) The State Government shall, if so directed by the Central Government, having regard to the number of vehicles, road conditions and other relevant matters, by notification in the Official Gazette, direct a State Transport Authority and a Regional Transport Authority to limit the number of contract carriages generally or of any specified type, as may be fixed and specified in the notification, operating on city routes in towns with a population of not less than five lakhs.
- (b) Where the number of contract carriages are fixed under clause (a), the Regional Transport Authority shall, in considering an application for the grant of permit in respect of any such contract carriage, have regard to the following matters, namely:-
- (i) financial stability of the applicant;
 - (ii) satisfactory performance as a contract carriage operator including payment of tax if the applicant is or has been an operator of contract carriages; and
 - (iii) such other matters as may be prescribed by the State Government:
- Provided that, other conditions being equal, preference shall be given to applications for permits from-
- (i) the India Tourism Development Corporation;
 - (ii) State Tourism Development Corporations;
 - (iii) State Tourism Departments;
 - (iv) State Transport Undertakings;
 - (v) co-operative societies registered or deemed to have been registered under any enactment for the time being in force;

(vi) ex-servicemen.

75. Scheme for renting of motor cabs.

(1) The Central Government may, by notification in the Official Gazette, make a scheme for the purpose of regulating the business of renting of¹[motor cabs or motor cycles to persons desiring to drive either by themselves or through drivers, motor cabs or motor cycles] for their own use and for matters connected therewith.

2) A scheme made under sub-section (1) may provide for all or any of the following matters, namely:-

- (a) licensing of operators under the scheme including grant, renewal and revocation of such licences;
- (b) form of application and form of licences and the particulars to be contained therein;
- (c) fee to be paid with the application for such licences;
- (d) the authorities to which the application shall be made;
- (e) condition subject to which such licences may be granted, renewed or revoked;
- (f) appeals against orders of refusal to grant or renew such licences and appeals against orders revoking such licences;
- (g) conditions subject to which motor cabs may be rented;
- (h) maintenance of records and inspection of such records;
- (i) such other matters as may be necessary to carry out the purposes of this section.

76. Application for private service vehicle permit.

(1) A regional Transport Authority may, on an application made to it, grant a private service vehicle permit in accordance with the application or with such modification as it deems fit or refuse to grant such permit:

Provided that no such permit shall be granted in respect of any area or route not specified in the application.

(2) An application for a permit to use a motor vehicle as a private service vehicle shall contain the following particulars, namely:-

- (a) type and seating capacity of the vehicle;
- (b) the area or the route or routes to which the application relates;

1. Subs, by Act 54 of 1994, sec. 24, for "motor cabs to persons desiring to drive the cabs" (w.e.f. 14-11-1994).

- (c) the manner in which it is claimed that the purpose of carrying persons otherwise than for hire or reward or in connection with the trade or business carried on by the applicant will be served by vehicle; and
 - (d) any other particulars which may be prescribed.
- (3) The Regional Transport Authority if it decides to grant the permit may subject to any rules that may be made under this Act, attach to the permit any one or more of the following conditions, namely:-
- (i) that the vehicle be used only in a specified area or on a specified route or routes;
 - (ii) the maximum number of persons and the maximum weight of luggage that may be carried;
 - (iii) that the Regional Transport Authority may, after giving notice of not less than one month-
 - (a) vary the conditions of the permit;
 - (b) attach to the permit further conditions;
 - (iv) that the conditions of permit shall not be departed from, save with the approval of the Regional Transport Authority;
 - (v) that specified standards of comforts and cleanliness shall be maintained in the vehicle;
 - (vi) that the holder of the permit shall furnish to the Regional Transport Authority such periodical returns, statistics and other information as the State Government may, from time to time, specify; and
 - (vii) such other conditions as may be prescribed.

77. Application for goods carriage permit.

An application for a permit to use a motor vehicle for the carriage of goods for hire or reward or for the carriage of goods for or in connection with a trade or business carried on by the applicant (in this Chapter referred to as a goods carriage permit) shall, as far as may be contain the following particulars, namely:-

- (a) the area or the route or routes to which the application relates;
- (b) the type and capacity of the vehicle;
- (c) the nature of the goods it is proposed to carry;
- (d) the arrangements intended to be made for the housing, maintenance and repair of the vehicle and for the storage and safe custody of the goods;

- (e) such particulars as the Regional Transport Authority may require with respect to any business as a carrier of goods for hire or reward carried on by the applicant at any time before the making of the application, and of the rates charged by the applicant;
- (f) particulars of any agreement, or arrangement, affecting in any material respect the provision within the region of the Regional Transport Authority of facilities for the transport of goods for hire or reward, entered into by the applicant with any other person by whom such facilities are provided, whether within or without the region;
- (g) any other particulars which may be prescribed.

78. Consideration of application for goods carriage permit.

A Regional Transport Authority shall, in considering an application for a goods carriage permit, have regard to the following matters, namely:-

- (a) the nature of the goods to be carried with special reference to their dangerous or hazardous nature to human life;
- (b) the nature of the chemicals or explosives to be carried with special reference to the safety to human life.

79. Grant of goods carriage permit.

(1) A Regional Transport Authority may, on an application made to it under section 77, grant a goods carriage permit to be valid throughout the State or in accordance with the application or with such modifications as it deems fit or refuse to grant such a permit:

Provided that no such permit shall be granted in respect of any area or route not specified in the application.

(2) The Regional Transport Authority, if it decides to grant a goods carriage permit, may grant the permit and may, subject to any rules that may be made under this Act, attach to the permit any one or more of the following conditions, namely:-

- (i) that the vehicle shall be used only in a specified area, or on a specified route or routes;
- (ii) that the gross vehicle weight of any vehicle used shall not exceed a specified maximum;
- (iii) that goods of a specified nature shall not be carried;
- (iv) that goods shall be carried at specified rates;
- (v) that specified arrangement shall be made for the housing, maintenance and repair of the vehicle and the storage and safe custody of the goods carried;

- (vi) that the holder of the permit shall furnish to the Regional Transport Authority such periodical returns, statistics and other information as the State Government may, from time to time, prescribe;
 - (vii) that the Regional Transport Authority may, after giving notice of not less than one month,-
 - (a) vary the conditions of the permit;
 - (b) attach to the permit further conditions;
 - (viii) that the conditions of the permit shall not be departed from, save with the approval of the Regional Transport Authority;
 - (ix) any other conditions which may be prescribed.
- (3) The conditions referred to in sub-section (2) may include conditions relating to the packaging and carriage of goods of dangerous or hazardous nature to human life

80. Procedure in applying for and granting permits.

- (1) An application for a permit of any kind may be made at any time.
- (2) A ¹[Regional Transport Authority, State Transport Authority or any prescribed authority referred to in sub-section (1) of section 66] shall not ordinarily refuse to grant an application for permit of any kind made at any time under this Act:

Provided that the ¹[Regional Transport Authority, State Transport Authority or any prescribed authority referred to in sub-section (1) of section 66] may summarily refuse the application if the grant of any permit in accordance with the application would have the effect of increasing the number of stage carriages as fixed and specified in a notification in the Official Gazette under clause (a) of sub-section (3) of section 71 or of contract carriages as fixed and specified in a notification in the Official Gazette under clause (a) of sub-section (3) of section 74:

Provided further that where a ¹[Regional Transport Authority, State Transport Authority or any prescribed authority referred to in sub-section (1) of section 66] refuses an application for the grant of a permit of any kind under this Act, it shall give to the applicant in writing its reasons for the refusal of the same and an opportunity of being heard in the matter.

- (3) An application to vary the conditions of any permit, other than a temporary permit, by the inclusion of a new route or routes or a new area or by altering the route or routes or area covered by it, or in the case of a stage carriage permit by increasing the number of trips above the specified maximum or by the variation, extension or curtailment of the route or routes or the area specified in the permit shall be treated as an application for the grant of a new permit:

Provided that it shall not be necessary so to treat an application made by the holder of stage carriage permit who provides the only service on any route to increase the frequency of the service so provided without any increase in the number of vehicles:

Provided further that,-

- (i) in the case of variation, the termini shall not be altered and the distance covered by the variation shall not exceed twenty-four kilometres;

1. Subs. by Act 54 of 1994, sec. 25, for "Regional Transport Authority" (w.e.f. 14-11-1994).

- (ii) in the case of extension, the distance covered by extension shall not exceed twenty-four kilometres from the termini,

and any such variation or extension within such limits shall be made only after the transport authority is satisfied that such variation will serve the convenience of the public and that it is not expedient to grant a separate permit in respect of the original route as so varied or extended or any part thereof.

(4) A ¹[Regional Transport Authority, State Transport Authority or any prescribed authority referred to in sub-section (1) of section 66] may, before such date as may be specified by it in this behalf, replace any permit granted by it before the said date by a fresh permit conforming to the provisions of section 72 or section 74 or section 76 or section 79, as the case may be, and the fresh permit shall be valid for the same route or routes or the same area for which the replaced permit

Provided that no condition other than a condition which was already attached to the replaced permit or which could have been attached thereto under the law in force when that permit was granted shall be attached to the fresh permit except with the consent in writing of the holder of the permit.

(5) Notwithstanding anything contained in section 81, a permit issued under the provisions of sub-section (4) shall be effective without renewal for the remainder of the period during which the replaced permit would have been so effective.

81. Duration and renewal of permits.

(1) A permit other than a temporary permit issued under section 87 or a special permit issued under sub-section (8) of section 88 shall be effective²[from the date of issuance or renewal thereof] for a period of five years:

Provided that where the permit is countersigned under sub-section (1) of section 88, such counter-signature shall remain effective without renewal for such period so as to synchronise with the validity of the primary permit.

(2) A permit may be renewed on an application made not less than fifteen days before the date of its expiry.

(3) Notwithstanding anything contained in sub-section (2), the Regional Transport Authority or the State Transport Authority as the case may be, entertain an application for the renewal of a permit after the last date specified in that sub-section if it is satisfied that the applicant was prevented by good and sufficient cause from making an application within the time specified.

(4) The Regional Transport Authority or the State Transport Authority, as the case may be, may reject an application for the renewal of a permit on one or more of the following grounds, namely:-

1.Subs. by Act 54 of 1994, sec. 25, for "Regional Transport Authority" (w.e.f. 14-11-1994).

Subs. by Act 54 of 1994, sec. 26 for "without renewal" (w.e.f. 14-11-1994).

- (a) the financial condition of the applicant as evidenced by insolvency, or decrees for payment of debts remaining unsatisfied for a period of thirty days, prior to the date of consideration of the application;
- (b) the applicant had been punished twice or more for any of the following offences within twelve months reckoned from fifteen days prior to the date of consideration of the application committed as a result of the operation of a stage carriage service by the applicant, namely:-
 - (i) plying any vehicle-
 - (1) without payment of tax due on such vehicle;
 - (2) without payment of tax during the grace period allowed for payment of such tax and then stop the plying of such vehicle;
 - (3) on any unauthorised route;
 - (ii) making unauthorised trips:

Provided that in computing the number of punishments for the purpose of clause (b), any punishment stayed by the order of an appellate authority shall not be taken into account:

Provided further that no application under this sub-section shall be rejected unless an opportunity of being heard is given to the applicant.

(5) Where a permit has been renewed under this section after the expiry of the period thereof, such renewal shall have effect from the date of such expiry irrespective of whether or not a temporary permit has been granted under clause (d) of section 87, and where a temporary permit has been granted, the fee paid in respect of such temporary permit shall be refused.

82. Transfer of permit.

(1) Save as provided in sub-section (2), a permit shall not be transferable from one person to another except with the permission of the transport authority which granted the permit and shall not, without such permission, operate to confer on any person to whom a vehicle covered by the permit is transferred any right to use that vehicle in the manner authorised by the permit.

(2) Where the holder of a permit dies, the person succeeding to the possession of the vehicle covered by the permit may, for a period of three months, use the permit as if it had been granted to himself:

Provided that such person has, within thirty days of the death of the holder, informed the transport authority which granted the permit of the death of the holder and of his own intention to use the permit:

Provided further that no permit shall be so used after the date on which it would have ceased to be effective without renewal in the hands of the deceased holder.

(3) The transport authority may, on application made to it within three months of the death of the holder of a permit, transfer the permit to the person succeeding to the possession of the vehicles covered by the permit:

Provided that the transport authority may entertain an application made after the expiry of the said period of three months if it is satisfied that the applicant was prevented by good and sufficient cause from making an application within the time specified.

83. Replacement of vehicles.

The holder of a permit may, with the permission of the authority by which the permit was granted, replace any vehicle covered by the permit by any other vehicle of the same nature.

84. General conditions attaching to all permits.

The following shall be conditions of every permit-

- (a) that the vehicle to which the permit relates carries valid certificate of fitness issued under section 56 and is at all times so maintained as to comply with the requirements of this Act and the rules made thereunder;
 - (b) that the vehicle to which the permit relates is not driven at a speed exceeding the speed permitted under this Act;
 - (c) that any prohibition or restriction imposed any fares or freight fixed by notification made under section 67 are observed in connection with the vehicle to which the permit relates;
 - (d) that the vehicle to which the permit relates is not driven in contravention of the provisions of section 5 or section 113;
 - (e) that the provisions of this Act limiting the hours of work of drivers are observed in connection with any vehicle or vehicles to which the permit relates;
 - (f) that the provisions of Chapters X, XI, and XII so far as they apply to the holder of the permit are observed; and
 - (g) that the name and address of the operator shall be painted or otherwise firmly affixed to every vehicle to which the permit relates on the exterior of the body of that vehicle on both sides thereof in a colour or colours vividly contrasting to the colour of the vehicle centred as high as practicable below the window line in bold letters.
-

85. General form of permits.

Every permit issued under this Act shall be complete in itself and shall contain all the necessary particulars of the permit and the conditions attached thereto.

86. Cancellation and suspension of permits.

- (1) The transport authority which granted a permit may cancel the permit or may suspend it for such period as it thinks fit-
- (a) on the breach of any condition specified in section 84 or of any condition contained in the permit, or
 - (b) if the holder of the permit uses or causes or allows a vehicle to be used in any manner not authorised by the permit, or
 - (c) if the holder of the permit ceases to own the vehicle covered by the permit, or
 - (d) if the holder of the permit has obtained the permit by fraud or misrepresentation, or
 - (e) if the holder of the goods carriage permit, fails without reasonable cause, to use the vehicle for the purposes for which the permit was granted, or
 - (f) if the holder of the permit acquires the citizenship of any foreign country:

Provided that no permit shall be suspended or cancelled unless an opportunity has been given to the holder of the permit to furnish his explanation

- (2) The transport authority may exercise the powers conferred on it under sub-section (1) in relation to a permit granted by any authority or person to whom power in this behalf has been delegated under sub-section (5) of section 68 as if the said permit was a permit granted by the transport authority.
- (3) Where a transport authority cancels or suspends a permit, it shall give to the holder in writing its reasons for the action taken.
- (4) The powers exercisable under sub-section (1) (other than the power to cancel a permit) by the transport authority which granted the permit may be exercised by any authority or person to whom such powers have been delegated under sub-section (5) of section 68.
- (5) Where a permit is liable to be cancelled or suspended under clause (a) or clause (b) or clause (e) of sub-section (1) and the transport authority is of opinion that having regard to the circumstances of the case, it would not be necessary or expedient so to cancel or suspend the permit if the holder of the permit agrees to pay a certain sum of money, then, notwithstanding anything contained in sub-section (1), the transport authority may, instead of cancelling or suspending the permit, as the case may be, recover from the holder of the permit the sum of money agreed upon.

(6) The powers exercisable by the transport authority under sub-section (5) may, where an appeal has been preferred under section 89, be exercised also by the appellate authority.

(7) In relation to a permit referred to in sub-section (9) of section 88, the powers exercisable under sub-section (1) (other than the power to cancel a permit) by the transport authority which granted the permit, may be exercised by any transport authority and any authority or persons to whom power in this behalf has been delegated under sub-section (5) of section 68, as if the said permit was a permit granted by any such authority or persons.

87. Temporary permits.

(1) A Regional Transport Authority and the State Transport Authority may without following the procedure laid down in section 80, grant permits to be effective for a limited period which shall, not in any case exceed four months, to authorise the use of a transport vehicle temporarily-

- (a) for the conveyance of passengers on special occasions such as to and from fairs and religious gatherings, or
- (b) for the purposes of a seasonal business, or
- (c) to meet a particular temporary need, or
- (d) pending decision on an application for the renewal of a permit, and may attach to any such permit such condition as it may think fit:

Provided that a Regional Transport Authority or, as the case may be, State Transport Authority may, in the case of goods carriages, under the circumstances of an exceptional nature, and for reasons to be recorded in writing, grant a permit for a period exceeding four months, but not exceeding one year.

(2) Notwithstanding anything contained in sub-section (1), a temporary permit may be granted thereunder in respect of any route or area where-

- (i) no permit could be issued under section 72 or section 74 or section 76 or section 79 in respect of that route or area by reason of an order of a Court or other competent authority restraining the issue of the same, for a period not exceeding the period for which the issue of the permit has been so restrained;
- (ii) as a result of the suspension by a Court or other competent authority of the permit of any vehicle in respect of that route or area, there is no transport vehicle of the same class with a valid permit in respect of that route or area, or there is no adequate number of such vehicles in respect of that route or area, for a period not exceeding the period of such suspension:

Provided that the number of transport vehicles in respect of which temporary permits are so granted shall not exceed the number of vehicles in respect of which the issue of the permits have been restrained or, as the case may be, the permit has been suspended.

88. Validation of permits for use outside region in which granted.

(1) Except as may be otherwise prescribed, a permit granted by the Regional Transport Authority of any one region shall not be valid in any other region, unless the permit has been countersigned by the Regional Transport Authority of that other region, and a permit granted in any one State shall not be valid in any other State unless countersigned by the State Transport Authority of that other State or by the Regional Transport Authority concerned:

Provided that a goods carriage permit, granted by the Regional Transport Authority of any one region, for any area in any other region or regions within the same State shall be valid in that area without the counter-signature of the Regional Transport Authority of the other region or of each of the other regions concerned:

Provided further that where both the starting point and the terminal point of a route are situate within the same State, but part of such route lies in any other State and the length of such part does not exceed sixteen kilometres, the permit shall be valid in the other State in respect of that part of the route which is in that other State notwithstanding that such permit has not been countersigned by the State Transport authority or the Regional Transport Authority of that other State:

Provided also that-

- (a) where a motor vehicle covered by a permit granted in one State is to be used for the purposes of defence in any other State, such vehicle shall display a certificate, in such form, and issued by such Authority, as the Central Government may, by notification in the Official Gazette, specify, to the effect that the vehicle shall be used for the period specified therein exclusively for the purposes of defence; and
 - (b) any such permit shall be valid in that other State notwithstanding that such permit has not been countersigned by the State Transport Authority or the Regional Transport Authority of that other State.
- (2) Notwithstanding anything contained in sub-section (1), a permit granted or countersigned by a State Transport Authority shall be valid in the whole State or in such regions within the State as may be specified in the permit.
- (3) A Regional Transport Authority when countersigning the permit may attach to the permit any condition which it might have imposed if it had granted the permit and may likewise vary any condition attached to the permit by the authority by which the permit was granted.
- (4) The provisions of this Chapter relating to the grant, revocation and suspension of permits shall apply to the grant, revocation and suspension of countersignatures of permits:

Provided that it shall not be necessary to follow the procedure laid down in section 80 for the grant of countersignatures of permits, where the permits granted in any one State are required to be countersigned by the State Transport Authority or another State or by the Regional Transport Authority concerned as a result of any agreement arrived at between the States after complying with the requirements of sub-section (5).

(5) Every proposal to enter into an agreement between the States to fix the number of permits which is proposed to be granted or countersigned in respect of each route or area, shall be published by each of the State Governments concerned in the Official Gazette and in any one or more of the newspapers in regional language circulating in the area or route proposed to be covered by the agreement together with a notice of the date before which representations in connection therewith may be submitted, and the date not being less than thirty days from the date of publication in the Official Gazette, on which, and the authority by which, and the time and place at which, the proposal and any representation received in connection therewith will be considered.

(6) Every agreement arrived at between the States shall, in so far as it relates to the grant of countersignature of permits, be published by each of the State Governments concerned in the Official Gazette and in any one or more of the newspapers in the regional language circulating in the area or route covered by the agreement and the State Transport Authority of the State and the Regional Transport Authority concerned shall give effect to it.

(7) Notwithstanding anything contained in sub-section (1), a Regional Transport Authority of one region may issue a temporary permit under section 87 to be valid in another region or State with the concurrence, given generally or for the particular occasion, of the Regional Transport Authority of that other region or of the State Transport Authority of that other State, as the case may be.

(8) Notwithstanding anything contained in sub-section (1), but subject to any rules that may be made under this Act by the Central Government, the Regional Transport Authority of any one region or, as the case may be, the State Transport Authority may, for the convenience of the public,¹[grant a special permit to any public service vehicle including any vehicle covered] by a permit issued under section 72 (including a reserve stage carriage) or under section 74 or under subsection (9) of this section for carrying a passenger or passengers for hire or reward under a contract, express or implied, for the use of the vehicle as a whole without stopping to pick up or set down along the line of route passengers not included in the contract, and in every case where such special permit is granted, the Regional Transport Authority shall assign to the vehicle, for display thereon, a special distinguishing mark in the form and manner specified by the Central Government and such special permit shall be valid in any other region or State without the countersignature of the Regional Transport Authority of the other region or of the State Transport Authority of the other State, as the case may be.

(9) Notwithstanding anything contained in sub-section (1) but subject to any rules that may be made by the Central Government under sub-section (14), any State Transport Authority may, for the purpose of promoting tourism, grant permits in respect of tourist vehicles valid for the whole of India, or in such contiguous States not being less than three in number including the State in which the permit is issued as may be specified in such permit in accordance with the choice indicated in the application and the provisions of sections 73, 74, 80, 81, 82, 83, 84, 85, 86 ²[clause (d) of sub-section (1) of section 87 and section 89] shall, as far as may be, apply in relation to such permits.

³[***]

1. Subs, by Act 54 of 1994, sec. 27, for "grant a special permit in relation to a vehicle covered" (w.e.f. 14-11-1994).

2. Subs. by Act 54 of 1994, sec. 27, for "and 89" (w.e.f. 14-11-1994).

3. Sub-section (10) omitted by Act 54 of 1994, sec. 27 (w.e.f. 14-11-1994).

(11) The following shall be conditions of every permit granted under subsection (9), namely:-

- (i) every motor vehicle in respect of which such permit is granted shall conform to such description, requirement regarding the seating capacity, standards of comforts, amenities and other matters, as the Central Government may specify in this behalf;
- (ii) every such motor vehicle shall be driven by a person having such qualifications and satisfying such conditions as may be specified by the Central Government; and
- (iii) such other conditions as may be prescribed by the Central Government.

(12) Notwithstanding anything contained in sub-section (1), but, subject to the rule that may be made by the Central Government under sub-section (14), the appropriate authority may, for the purpose of encouraging long distance inter-State road transport, grant in a State, national permits in respect of goods carriages and the provisions of sections 69, 77, 79, 80, 81, 82, 83, 84, 85, 86, ¹[clause (d) of sub-section (1) of section 87 and section 89] shall, as far as may be, apply to or in relation to the grant of national permits.

²[***]

(14)

- (a) The Central Government may make rules for carrying out the provisions of this section.
- (b) In particular, and without prejudice to the generality of the foregoing power, such rules may provide for all or any of the following matters, namely:-
 - (i) the authorisation fee payable of the issue of a permit referred to in sub-sections (9) and (12);
 - (ii) the fixation of the laden weight of the motor vehicle;
 - (iii) the distinguishing particulars or marks to be carried or exhibited in or on the motor vehicle;
 - (iv) the colour or colours in which the motor vehicle is to be painted;
 - (v) such other matters as the appropriate authority shall consider in granting a national permit.

Explanation.-In this section,-

- (a) "appropriate authority", in relation to a national permit, means the authority which is authorised under this Act to grant a goods carriage permit;

1. Sub. by Act 54 of 1994, sec. 27, for "and 89" (w.e.f. 14-11-1994).

2. Sub-section (13) omitted by Act 54 of 1994, sec. 27 (w.e.f. 14-11-1994).

- (b) "authorisation fee" means the annual fee, not exceeding one thousand rupees, which may be charged by the appropriate authority of a State to enable a motor vehicle, covered by the permit referred to in sub-sections (9) and (12) to be used in other States subject to the payment of taxes or fees, if any, levied by the States concerned;
- (c) "national permit" means a permit granted by the appropriate authority to goods carriages to operate throughout the territory of India or in such contiguous States, not being less than four in number, including the State in which the permit is issued as may be specified in such permit in accordance with the choice indicated in the application.

89. Appeals.

- (1) Any person-
 - (a) aggrieved by the refusal of the State or a Regional Transport Authority to grant a permit, or by any condition attached to a permit granted to him, or
 - (b) aggrieved by the revocation or suspension of the permit or by any variation of the conditions thereof, or
 - (c) aggrieved by the refusal to transfer the permit under section 82, or
 - (d) aggrieved by the refusal of the State or a Regional Transport Authority to countersign a permit, or by any condition attached to such countersignature, or
 - (e) aggrieved by the refusal of renewal of a permit, or
 - (f) aggrieved by the refusal to grant permission under section 83, or
 - (g) aggrieved by any other order which may be prescribed, may, within the prescribed time and in the prescribed manner, appeal to the State Transport Appellate Tribunal constituted under sub-section (2), who shall, after giving such person and the original authority an opportunity of being heard, give a decision thereon which shall be final.

¹[(2) The State Government shall constitute such number of Transport Appellate Tribunals as it thinks fit and each such Tribunal shall consist of a judicial officer who is not below the rank of a District Judge or who is qualified to be a Judge of the High Court and it shall exercise jurisdiction within such area as may be notified by that Government.]

(3) Notwithstanding anything contained in sub-section (1) or sub-section (2), every appeal pending at the commencement of this Act, shall continue to be proceeded with and disposed of as if this Act had not been passed.

Explanation.-For the removal of doubts, it is hereby declared that when any order is made by the State Transport Authority or the Regional Transport Authority in pursuance of a direction issued by the Inter-State Transport Commission under clause (c) of sub-section (2) of section 63A of the Motor Vehicles Act, 1939 (4 of 1939), as it stood immediately before the commencement of this Act, and any person feels aggrieved by such order on the ground that it

1. Subs. by Act 54 of 1994, sec. 28, for sub-section (2) (w.e.f. 14-11-1994).

is not in consonance with such direction, he may appeal under sub-section (1) to the State Transport Appellate Tribunal against such order but not against the direction so issued.

90. Revision.

The State Transport Appellate Tribunal may, on an application made to it, call for the record of any case in which an order has been made by a State Transport Authority or Regional Transport Authority against which no appeal lies, and if it appears to the State Transport Appellate Tribunal that the order made by the State Transport Authority or Regional Transport Authority is improper or illegal, the State Transport Appellate Tribunal may pass such order in relation to the case as it deems fit and every such order shall be final:

Provided that the State Transport Appellate Tribunal shall not entertain any application from a person aggrieved by an order of a State Transport Authority or Regional Transport Authority, unless the application is made within thirty days from the date of the order:

Provided further that the State Transport Appellate Tribunal may entertain the application after the expiry of the said period of thirty days, if it is satisfied that the applicant was prevented by good and sufficient cause from making the application in time:

Provided also that the State Transport Appellate Tribunal shall not pass an order under this section prejudicial to any person without giving him a reasonable opportunity of being heard.

91. Restriction of hours of work of drivers.

¹(1) The hours of work of any person engaged for operating a transport vehicle shall be such as provided in the Motor Transport Workers Act, 1961 (7 of 1961)].

(2) A State Government may, by notification in the Official Gazette, grant such exemptions from the provisions of sub-section (1) as it thinks fit, to meet cases of emergency or of delays by reason of circumstances which could not be foreseen.

(3) A State Government or, if authorised in this behalf by the State Government by rules made under section 96, the State or a Regional Transport Authority may require persons employing any person whose work is subject to any of the provisions of sub-section (1) to fix beforehand the hours of work of such persons so as to conform to those provisions, and may provide for the recording of the hours so fixed.

(4) No person shall work or shall cause or allow any other person to work outside the hours fixed or recorded for the work of such persons under subsection (3).

(5) A State Government may prescribe the circumstances under which and the period during which the driver of a vehicle although not engaged in work is required to remain on or near the vehicle may be deemed to be an interval for rest within the meaning of sub-section (1).

¹ Subs. by Act 54 of 1994, sec. 29, for sub-section (1) (w.e.f. 14-11-1994).

92. Voidance of contracts restrictive of liability.

Any contract for the conveyance of a passenger in a stage carriage or contract carriage, in respect of which a permit has been issued under this Chapter, shall, so far as it purports to negative or restrict the liability of any person in respect of any claim made against that person in respect of the death of, or bodily injury to, the passenger while being carried in, entering or alighting from the vehicle, or purports to impose any conditions with respect to the enforcement of any such liability, be void.

93. Agent or canvasser to obtain licence.

(1) No person shall engage himself-

- (i) as an agent or a canvasser, in the sale of tickets for travel by public service vehicles or in otherwise soliciting customers for such vehicles, or
- (ii) as an agent in the business of collecting, forwarding or distributing goods carried by goods carriages,

unless he has obtained a licence from such authority and subject to such conditions as may be prescribed by the State Government.

(2) The conditions referred to in sub-section (1) may include all or any of the following matters, namely:-

- (a) the period for which a licence may be granted or renewed;
- (b) the fee payable for the issue or renewal of the licence;
- (c) the deposit of security-
 - (i) of a sum not exceeding rupees fifty thousand in the case of an agent in the business of collecting, forwarding or distributing goods carried by goods carriages,
 - (ii) of a sum not exceeding rupees five thousand in the case of any other agent or canvasser,

and the circumstances under which the security may be forfeited;

- (d) the provision by the agent of insurance of goods in transit;
- (e) the authority by which and the circumstances under which the licence may be suspended or revoked;
- (f) such other conditions as may be prescribed by the State Government.

(3) It shall be a condition of every licence that no agent or canvasser to whom the licence is granted shall advertise in any newspaper, book, list, classified directory or other publication unless there is contained in such advertisement appearing in such newspaper, book, list,

classified directory or other publication the licence number, the date of expiry of licence and the particulars of the authority which granted the licence.

94. Bar on jurisdiction of Civil Courts.

No Civil Court shall have jurisdiction to entertain any question relating to the grant of a permit under this Act, and no injunction in respect of any action taken or to be taken by the duly constituted authorities under this Act with regard to the grant of a permit, shall entertained by any Civil Court.

95. Power of State Government to make rules as to stage carriages and contract carriages.

- (1) A State Government may make rules to regulate, in respect of stage carriages and contract carriages and the conduct of passengers in such vehicles.
- (2) Without prejudice to the generality of the foregoing provision, such rules may-
 - (a) authorise the removal from such vehicle of any person contravening the rules by the driver or conductor of the vehicle, or, on the request of the driver or conductor, or any passenger, by any police officer;
 - (b) require a passenger who is reasonably suspected by the driver or conductor of contravening the rules to give his name and address to a police officer or to the driver or conductor on demand;
 - (c) require a passenger to declare, if so demanded by the driver or conductor, the journey he intends to take or has taken in the vehicle and to pay the fare for the whole of such journey and to accept any ticket issued therefor;
 - (d) require, on demand being made for the purpose by the driver or conductor or other person authorised by the owners of the vehicle, production during the journey and surrender at the end of the journey by the holder thereof of any ticket issued to him;
 - (e) require a passenger, if so requested by the driver or conductor, to leave the vehicle on the completion of the journey the fare for which he has paid;
 - (f) require the surrender by the holder thereof on the expiry of the period for which it is issued of a ticket issued to him;
 - (g) require a passenger to abstain from doing anything which is likely to obstruct or interfere with the working of the vehicle or to cause damage to any part of the vehicle or its equipment or to cause injury or discomfort to any other passenger;
 - (h) require a passenger not to smoke in any vehicle on which a notice prohibiting smoking is exhibited;
 - (i) require the maintenance of complaint books in stage carriages and prescribe the conditions under which passengers can record any complaints in the same.

96. Power of State Government to make rules for the purposes of this Chapter.

- (1) A State Government may make rules for the purpose of carrying into effect the provisions of this Chapter.
- (2) Without prejudice to the generality of the foregoing power, rules under this section may be made with respect to all or any of the following matters, namely:-

- (i) the period of appointment and the terms of appointment of and the conduct of business by Regional and State Transport Authorities and the reports to be furnished by them;
- (ii) the conduct of business by any such authority in the absence of any member (including the Chairman) thereof and the nature of business which, the circumstances under which and the manner in which, business could be so conducted;
- (iii) The conduct and hearing of appeals that may be preferred under this Chapter, the fees to be paid in respect of such appeals and the refund of such fees;
- (iv) the forms to be used for the purposes of this Chapter, including the forms or permits;
- (v) the issue of copies of permits in place of permits lost, destroyed or mutilated;
- (vi) the documents, plates and marks to be carried by transport vehicles, the manner in which they are to be carried and the languages in which any such documents are to be expressed;
- (vii) the fees to be paid in respect of applications for permits, duplicate permits and plates;
- (viii) the exemption of prescribed person or prescribed classes of persons from payment of all or any or any portion of the fees payable under this Chapter;
- (ix) the custody, production and cancellation on revocation or expiration of permits, and the return of permits which have been cancelled;
- (x) the conditions subject to which, and the extent to which, a permit granted in another State shall be valid in the State without countersignature;
- (xi) the conditions subject to which, and the extent to which, a permit granted in one region shall be valid in another region within the State without countersignature;
- (xii) the conditions to be attached to permits for the purpose of giving effect to any agreement such as is referred to in clause (iii) of subsection (1) of section 67;
- (xiii) the authorities to whom, the time within which and the manner in which appeals may be made;
- (xiv) the construction and fittings of, and the equipment to be carried by, stage and contract carriages, whether generally or in specified areas;
- (xv) the determination of the number of passengers a stage or contract carriage is adapted to carry and the number which may be carried;
- (xvi) the conditions subject to which goods may be carried on stage and contract carriages partly or wholly in lieu of passengers;

- (xvii) the safe custody and disposal of property left in a stage or contract carriage;
- (xviii) regulating the painting or marking of transport vehicles and the display of advertising matter thereon, and in particular prohibiting the painting or marking of transport vehicles in such colour or manner as to induce any person to believe that the vehicle is used for the transport of mails;
- (xix) the conveyance in stage or contract carriages of corpses or persons suffering from any infectious or contagious disease or goods likely to cause discomfort or injury to passengers and the inspection and disinfection of such carriages if used for such purposes;
- (xx) the provision of taxi meters on motor cabs requiring approval or standard types of taxi meters to be used and examining testing and sealing taxi meters;
- (xxi) prohibiting the picking up or setting down of passengers by stage or contract carriages at specified places or in specified areas or at places other than duly notified stands or halting places and requiring the driver of a stage carriage to stop and remain stationary for, a reasonable time when so required by a passenger desiring to board or alight from the vehicle at a notified halting place;
- (xxii) the requirements which shall be complied with in the construction or use of any duly notified stand or halting place, including the provision of adequate equipment and facilities for the convenience of all users thereof; the fees, if any, which may be charged for the use of such facilities, the records which shall be maintained at such stands or places, the staff to be employed thereat, and the duties and conduct of such staff, and generally for maintaining such stands and places in a serviceable and clean condition;
- (xxiii) the regulation of motor cab ranks;
- (xxiv) requiring the owners of transport vehicles to notify any change of address or to report the failure of or damage to any vehicle used for the conveyance of passengers for hire or reward;
- (xxv) authorising specified persons to enter at all reasonable times and inspect all premises used by permit holders for the purposes of their business;
- (xxvi) requiring the person in charge of a stage carriage to carry any person tendering the legal or customary fare;
- (xxvii) the conditions under which and the types of containers or vehicles in which animals or birds may be carried and the seasons during which animals or birds may or may not be carried;
- (xxviii) the licensing of and the regulation of the conduct of agents or canvassers who engage in the sale of tickets for travel by public service vehicles or otherwise solicit customers for such vehicles;

- (xxix) the licensing of agents engaged in the business of collecting for forwarding and distributing goods carried by goods carriages;
- (xxx) the inspection of transport vehicles and their contents and of the permits relating to them;
- (xxxi) the carriage of persons other than the driver in goods carriages;
- (xxxii) the records to be maintained and the returns to be furnished by the owners of transport vehicles; and
- (xxxiii) any other matter which is to be or may be prescribed.

CHAPTER VI
SPECIAL PROVISIONS RELATING TO STATE TRANSPORT UNDERTAKINGS

97. Definition.

In this Chapter, unless the context otherwise requires, "road transport service" means a service of motor vehicles carrying passengers or goods or both by road for hire or reward.

98. Chapter to override Chapter V and other laws.

The provisions of this Chapter and the rules and orders made thereunder shall have effect notwithstanding anything inconsistent therewith contained in Chapter V or in any other law for the time being in force or in any instrument having effect by virtue of any such law

99. Preparation and publication of proposal regarding road transport service of a State transport undertaking.

¹[(1) Where any State Government is of opinion that for the purpose of providing an efficient, adequate, economical and properly co-ordinated road transport service, it is necessary in the public interest that road transport services in general or any particular class of such service in relation to any area or route or portion thereof should be run and operated by the State transport undertaking, whether to the exclusion, complete or partial, of other persons or otherwise, the State Government may formulate a proposal regarding a scheme giving particulars of the nature of the services proposed to be rendered, the area or route proposed to be covered and other relevant particulars respecting thereto and shall publish such proposal in the Official Gazette of the State formulating such proposal and in not less than one newspaper in the regional language circulating in the area or route proposed to be covered by such scheme and also in such other manner as the State Government formulating such proposal deem fit. ²[(2) Notwithstanding anything contained in sub-section (1), when a proposal is published under that sub-section, then from the date of publication of such proposal, no permit shall be granted to any person, except a temporary permit during the pendency of the proposal and such temporary permit shall be valid only for a period of one year from the date of its issue or till the date of final publication of the scheme under section 100, whichever is earlier.]

100. Objection to the proposal.

(1) On the publication of any proposal regarding a scheme in the Official Gazette and in not less than one newspaper in the regional language circulating in the area or route which is to be covered by such proposal any person may, within thirty days from the date of its publication in the Official Gazette, file objections to it before the State Government.

(2) The State Government may, after considering the objections and after giving an opportunity to the objector or his representatives and the representatives of the State transport undertaking to be heard in the matter, if they so desire, approve or modify such proposal.

1. Section 99 renumbered as sub-section (1) thereof by Act 54 of 1994, sec. 30 (w.e.f. 14-11-194),

2. Ins. by Act 54 of 1994, sec. 30 (w.e.f. 14-11-1994).

(3) The scheme relating to the proposal as approved or modified under subsection (2) shall then be published in the Official Gazette by the State Government making such scheme and in not less than one newspaper in the regional language circulating in the area or route covered by such scheme and the same shall thereupon become final on the date of its publication in the Official Gazette and shall be called the approved scheme and the area or route of which it relates shall be called the notified area or notified route:

Provided that no such scheme which relates to any inter-State route shall be deemed to be an approved scheme unless it has the previous approval of the Central Government.

(4) Notwithstanding anything contained in this section, where a scheme is not published as an approved scheme under sub-section (3) in the Official Gazette within a period of one year from the date of publication of the proposal regarding the scheme in the Official Gazette under sub-section (1), the proposal shall be deemed to have lapsed.

Explanation.-In computing the period of one year referred to in this sub-section, any period or periods during which the publication of the approved scheme under sub-section (3) was held up on account of any stay or injunction by the order of any Court shall be excluded.

101. Operation of additional services by a State transport undertaking in certain circumstances.

Notwithstanding anything contained in section 87, a State transport undertaking may, in the public interest operate additional services for the conveyance of the passengers on special occasions such as to and from fairs and religious gatherings:

Provided that the State transport undertaking shall inform about the operation of such additional services to the concerned Transport Authority without delay.

102. Cancellation or modification of scheme.

(1) The State Government may, at any time, if it considers necessary, in the public interest so to do, modify any approved scheme after giving-

- (i) the State transport undertaking; and
- (ii) any other person who, in the opinion of the State Government, is likely to be affected by the proposed modification,

and opportunity of being heard in respect of the proposed modification.

(2) The State Government shall publish any modification proposed under sub-section (1) in the Official Gazette and in one of the newspapers in the regional languages circulating in the area in which it is proposed to be covered by such modification, together with the date, not being less than thirty days from such publication in the Official Gazette, and the time and place at which any representation received in this behalf will be heard by the State Government.

103. Issue of permits to State transport undertakings.

(1) Where, in pursuance of an approved scheme, any State transport undertaking applies in such manner as may be prescribed by the State Government in this behalf for a stage carriage permit or a goods carriage permit or a contract carriage permit in respect of a notified area or notified route, the State Transport Authority in any case where the said area or route lies in more than one region and the Regional Transport Authority in any other case shall issue such permit to the State transport undertaking, notwithstanding anything to the contrary contained in Chapter V.

(2) For the purpose of giving effect to the approved scheme in respect of a notified area or notified route, the State Transport Authority or, as the case may be, the Regional Transport Authority concerned may, by order,-

- (a) refuse to entertain any application for the grant or renewal of any other permit or reject any such application as may be pending;
- (b) cancel any existing permit;
- (c) modify the terms of any existing permit so as to-
 - (i) render the permit ineffective beyond a specified date;
 - (ii) reduce the number of vehicles authorised to be used under the permit;
 - (iii) curtail the area or route covered by the permit in so far as such permit relates to the notified area or notified route.

(3) For the removal of doubts, it is hereby declared that no appeal shall lie against any action taken, or order passed, by the State Transport Authority or any Regional Transport Authority under sub-section (1) or sub-section (2).

STATE AMENDMENTS

Karnataka:

In section 103, after sub-section (1), insert the following sub-section, namely:-

"(1A) It shall be lawful for the State Transport Undertaking to operate on any route as stage carriage, under any permit issued therefor to such Undertaking under sub-section (1), any vehicle placed at the disposal and under the control of such Undertaking by the owner of such vehicle under any arrangement entered into between such owner and the Undertaking for the use of the said vehicle by the Undertaking."

[Karnataka Act 11 of 1996, sec. 2 (w.r.e.f. 8-7-1996)]

Uttar Pradesh:

In section 103, after sub-section (1), the following sub-section shall be inserted, namely:-

"(1A) It shall be lawful for a State transport undertaking to operate on any route as stage carriage, under any permit issued therefor to such undertaking under sub-section (1), any vehicle placed at the disposal and under the control of such undertaking by the owner of such vehicle under any arrangement entered into between such owner and the undertaking for the use of the said vehicle by the undertaking."

[Uttar Pradesh Act 5 of 1993, sec. 2 (w.r.e.f. 16-1-1993)].

104. Restriction on grant of permits in respect of a notified area or notified route.

Where a scheme has been published under sub-section (3) of section 100 in respect of any notified area or notified route, the State Transport Authority or the Regional Transport Authority, as the case may be, shall not grant any permit except in accordance with the provisions of the scheme:

Provided that where no application for a permit has been made by the State Transport Undertaking in respect of any notified area or notified route in pursuance of an approved scheme, the State Transport Authority or the Regional Transport Authority, as the case may be, may grant temporary permits to any person in respect of such notified area or notified route subject to the condition that such permit shall cease to be effective on the issue of a permit to the State transport undertaking in respect of that area or route.

105. Principles and method of determining compensation and payment thereof.

(1) Where, in exercise of the powers conferred by clause (b) or clause (c) of sub-section (2) of section 103, any existing permit is cancelled or the terms thereof are modified, there shall be paid by the State transport undertaking to the holder of the permit, compensation, the amount of which shall be determined in accordance with the provisions of sub-section (4) or sub-section (5), as the case may be.

(2) Notwithstanding anything contained in sub-section (1), no compensation shall be payable on account of the cancellation of any existing permit or any modification of the terms thereof, when a permit for an alternative route or area in lieu thereof has been offered by the State Transport Authority or the Regional Transport Authority, as the case may be and accepted by the holder of the permit.

(3) For the removal of doubts, it is hereby declared that no compensation shall be payable on account of the refusal to renew a permit under clause (a) of sub-section (2) of section 103.

(4) Where, in exercise of the powers conferred by clause (b) or sub-clause (i) or sub-clause (ii) of clause (c) of sub-section (2) of section 103, any existing permit is cancelled or the terms thereof are modified so as to prevent the holder of the permit from using any vehicle authorised to be used thereunder for the full period from which the permit, would otherwise have been effective, the compensation payable to the holder of the permit for each vehicle affected by such cancellation or modification shall be computed as follows:-

- (a) for every complete month or part of a month exceeding fifteen days of the unexpired period of the permit: Two hundred rupees;
- (b) for part of a month not exceeding fifteen days of the unexpired period of the permit; One hundred rupees:

Provided that the amount of compensation shall, in no case, be less than four hundred rupees.

(5) Where, in exercise of the powers conferred by sub-clause (iii) of clause (c) of sub-section (2) of section 103, the terms of an existing permit are modified so as to curtail the area or route of any vehicle authorised to be used thereunder, the compensation payable to the holder of the permit on account of such curtailment shall be an amount computed in accordance with the following formula, namely:- $Y \times A / R$

Explanation.-In this formula,-

- (i) "Y" means the length or area by which the route or area covered by the permit is curtailed;
- (ii) "A" means the amount computed in accordance with sub-section (4);
- (iii) "R" means the total length of the route or the total area covered by the permit.

(6) The amount of compensation payable under this section shall be paid by the State transport undertaking to the person or persons entitled thereto within one month from the date on which the cancellation or modification of the permit becomes effective:

Provided that where the State transport undertaking fails to make the payment within the said period of one month, it shall pay interest at the rate of seven per cent, per annum from the date on which it falls due.

106. Disposal of article found in vehicles.

Where any article found in any transport vehicle operated by the State transport undertaking is not claimed by its owner within the prescribed period, the State transport undertaking may sell the article in prescribed manner and the sale proceeds thereof, after deducting the costs incidental to sale, shall be paid to the owner on demand.

107. Power of State Government to make rules.

(1) The State Government may make rules for the purpose of carrying into effect the provisions of this Chapter.

(2) In particular and without prejudice to the generality of the foregoing power, such rules may provide for all or any of the following matters, namely:-

- (a) the form in which any proposal regarding a scheme may be published under section 99;
- (b) the manner in which objections may be filed under sub-section (1) of section 100;
- (c) the manner in which objections may be considered and disposed of under sub-section (2) of section 100;
- (d) the form in which any approved scheme may be published under sub-section (3) of section 100;

- (e) the manner in which application under sub-section (1) of section 103 may be made;
- (f) the period within which the owner may claim any article found left in any transport vehicle under section 106 and the manner of sale of such article;
- (g) the manner of service of orders under this Chapter;
- (h) any other matter which has to be, or may be, prescribed.

108. Certain powers of State Government exercisable by the Central Government.

The powers conferred on the State Government under this Chapter shall, in relation to a corporation or company owned or controlled by the Central Government or by the Central Government and one or more State Governments, be exercisable only by the Central Government in relation to an inter-State route or area.

CHAPTER VII

CONSTRUCTION, EQUIPMENT AND MAINTENANCE OF MOTOR VEHICLES

109. General provision regarding construction and maintenance of vehicles.

(1) Every motor vehicle shall be so constructed and so maintained as to be at all times under the effective control of the person driving the vehicle.

(2) Every motor vehicle shall be so constructed as to have right hand steering control unless it is equipped with a mechanical or electrical signalling device of prescribed nature.

¹[(3) If the Central Government is of the opinion that it is necessary or expedient so to do in public interest, it may by order published in the Official Gazette, notify that any article or process used by a manufacturer shall conform to such standard as may be specified in that order.]

110. Power of Central Government to make rules.

(1) The Central Government may make rules regulating the construction, equipment and maintenance of motor vehicles and trailers with respect to all or any of the following matters, namely:-

(a) the width, height, length and overhang of vehicles and of the loads carried;

²[(b) the size, nature, maximum retail price and condition of tyres, including embossing thereon of date and year of manufacture, and the maximum load carrying capacity;]

(c) brakes and steering gear;

(d) the use of safety glasses including prohibition of the use of tinted safety glasses;

(e) signalling appliances, lamps and reflectors;

(f) speed governors;

(g) the emission of smoke, visible vapour, sparks, ashes, grit or oil;

(h) the reduction of noise emitted by or caused by vehicles;

(i) the embossment of chassis number and engine number and the date of manufacture;

(j) safety belts, handle bars of motor cycles, auto-dippers and other equipments essential for safety of drivers, passengers and other road-users;

(k) standards of the components used in the vehicle as inbuilt safety devices;

1. Ins. by Act 54 of 1994, sec. 31 (w.e.f. 14-11-1994).

2. Subs. by Act 54 of 1994, sec. 32, for clause (b) (w.e.f. 14-11-1994).

- (l) provision for transportation of goods of dangerous or hazardous nature to human life;
- (m) standards for emission of air pollutants;
- ¹[(n) installation of catalytic convertors in the class of vehicles to be prescribed;
- (o) the placement of audio-visual or radio or tape recorder type of devices in public vehicles;
- (p) warranty after sale of vehicle and norms therefor:]

Provided that any rules relating to the matters dealing with the protection of environment, so far as may be, shall be made after consultation with the Ministry of the Government of India dealing with environment.

(2) Rules may be made under sub-section (1) governing the matters mentioned therein, including the manner of ensuring the compliance with such matters and the maintenance of motor vehicles in respect of such matters, either generally in respect of motor vehicles or trailers or in respect of motor vehicles or trailers of a particular class or in particular circumstances.

(3) Notwithstanding anything contained in this section,-

- (a) the Central Government may exempt any class of motor vehicles from the provisions of this Chapter;
- (b) a State Government may exempt any motor vehicle or any class or description of motor vehicles from the rules made under sub-section (1) subject to such conditions as may be prescribed by the Central Government.

111. Power of State Government to make rules.

(1) A State Government may make rules regulating the construction, equipment and maintenance of motor vehicles and trailers with respect to all matters other than the matters specified in sub-section (1) of section 110.

(2) Without prejudice to the generality of the foregoing power, rules may be made under this section governing all or any of the following matters either generally in respect of motor vehicles or trailers or in respect of motor vehicles or trailers of a particular class or description or in particular circumstances, namely:-

- (a) seating arrangements in public service vehicles and the protection of passengers against the weather;
- (b) prohibiting or restricting the use of audible signals at certain times or in certain places;

1. Ins. by Act 54 of 1994, sec. 32 (w.e.f. 14-11-1994).

- (c) prohibiting the carrying of appliances likely to cause annoyance or danger;
- (d) the periodical testing and inspection of vehicles by prescribed authorities ¹[and fees to be charged for such test];
- (e) the particulars other than registration marks to be exhibited by vehicles and the manner in which they shall be exhibited;
- (f) the use of trailers with motor vehicles; and

²[***]

1. Ins. by Act 54 of 1994 sec. 33 (w.e.f. 14-11-1994).

2. Clause (g) omitted by Act 54 of 1994 sec. 33 (w.e.f. 14-11-1994).

CHAPTER VIII CONTROL OF TRAFFIC

112. Limits of speed.

(1) No person shall drive a motor vehicle or cause or allow a motor vehicle to be driven in any public place at a speed exceeding the maximum speed or below the minimum speed fixed for the vehicle under this Act or by or under any other law for the time being in force:

Provided that such maximum speed shall in no case exceed the maximum fixed for any motor vehicle or class or description of motor vehicles by the Central Government by notification in the Official Gazette.

(2) The State Government or any authority authorised in this behalf by the State Government may, if satisfied that it is necessary to restrict the speed of motor vehicles in the interest of public safety or convenience or because of the nature of any road or bridge, by notification in the Official Gazette, and by causing appropriate traffic signs to be placed or erected under section 116 at suitable places, fix such maximum speed limits or minimum speed limits as it thinks fit for motor vehicles or any specified class or description of motor vehicles or for motor vehicles to which a trailer is attached, either generally or in a particular area or on a particular road or roads:

Provided that no such notification is necessary if any restriction under this section is to remain in force for not more than one month.

(3) Nothing in this section shall apply to any vehicle registered under section 60 while it is being used in the execution of military manoeuvres within the area and during the period specified in the notification under sub-section (1) of section 2 of the Manoeuvres, Field Firing and Artillery Practice Act, 1938 (5 of 1938).

113. Limits of weight and limitations on use.

(1) The State Government may prescribe the conditions for the issue of permits for ¹[transport vehicles] by the State or Regional Transport Authorities and may prohibit or restrict the use of such vehicles in any area or route.

(2) Except as may be otherwise prescribed, no person shall drive or cause or allow to be driven in any public place any motor vehicle which is not fitted with pneumatic tyres.

(3) No person shall drive or cause or allow to be driven in any public place any motor vehicle or trailer-

- (a) the unladen weight of which exceeds the unladen weight specified in the certificate of registration of the vehicle, or
- (b) the laden weight of which exceeds the gross vehicle weight specified in the certificate of registration.

1. Subs. by Act 54 of 1994, sec. 34, for "heavy goods vehicles or heavy passenger motor vehicles" (w.e.f. 14-11-1994).

(4) Where the driver or person in charge of a motor vehicle or trailer driven in contravention of sub-section (2) or clause (a) of sub-section (3) is not the owner, a Court may presume that the offence was committed with the knowledge of or under the orders of the owner of the motor vehicle or trailer.

114. Power to have vehicle weighed.

(1) ¹[Any officer of the Motor Vehicles Department authorised in this behalf by the State Government shall, if he has reason to believe that a goods vehicle or trailer is being used in contravention of section 113,] require the driver to convey the vehicle to a weighing device, if any, within a distance of ten kilometres from any point on the forward route or within a distance of twenty kilometres from the destination of the vehicle for weighing; and if on such weighing the vehicle is found to contravene in any respect the provisions of section 113 regarding weight, he may, by order in writing, direct the driver to off-load the excess weight at his own risk and not to remove the vehicle or trailer from that place until the laden weight has been reduced or the vehicle or trailer has otherwise been dealt with so that it complies with section 113 and on receipt of such notice, the driver shall comply with such directions.

(2) Where the person authorised under sub-section (1) makes the said order in writing, he shall also endorse the relevant details of the overloading on the goods carriage permit and also intimate the fact of such endorsement to the authority which issued that permit.

115. Power to restrict the use of vehicles.

The State Government or any authority authorised in this behalf by the State Government, if satisfied that it is necessary in the interest of public safety or convenience, or because of the nature of any road or bridge, may by notification in the Official Gazette, prohibit or restrict, subject to such exceptions and conditions as may be specified in the notification, the driving of motor vehicles or of any specified class or description of motor vehicles or the use of trailers either generally in a specified area or on a specified road and when any such prohibition or restriction is imposed, shall cause appropriate traffic signs to be placed or erected under section 116 at suitable places:

Provided that where any prohibition or/ restriction under this section is to remain in force for not more than one month, notification thereof in the Official Gazette shall not be necessary, but such local publicity as the circumstances may permit, shall be given of such prohibition or restriction.

116. Power to erect traffic signs.

(1) (a) The State Government or any authority authorised in this behalf by the State Government may cause or permit traffic signs to be placed or erected in any public place for the purpose of bringing to public notice any speed limits fixed under sub-section (2) of section 112 or any prohibitions or restrictions imposed under section 115 or generally for the purpose of regulating motor vehicle traffic.

1. Subs, by Act 54 of 1994, sec. 35, for certain words (w.e.f. 14-11-1994).

(b) A State Government or any authority authorised in this behalf by the State Government may, by notification in the Official Gazette or by the erection at suitable places of the appropriate traffic sign referred to in Part A of the Schedule, designate certain roads as main roads for the purposes of the driving regulations made by the Central Government.

(2) Traffic signs placed or erected under sub-section (1) for any purpose for which provision is made in the Schedule shall be of the size, colour and type and shall have the meanings set forth in the Schedule, but the State Government or any authority empowered in this behalf by the State Government may make or authorise the addition to any sign set forth in the said Schedule, of transcriptions of the words, letters or figures thereon in such script as the State Government may think fit provided that the transcriptions shall be of similar size and colour to the words, letters or figures set forth in the Schedule.

(3) Except as provided by sub-section (1), no traffic sign shall, after the commencement of this Act, be placed or erected on or near any road; but all traffic signs placed or erected prior to the commencement of this Act by any competent authority shall for the purpose of this Act by any competent authority shall for the purpose of this Act be deemed to be traffic signs placed or erected under the provisions of sub-section (1).

(4) A State Government may, by notification in the Official Gazette, empower any police officer not below the rank of a Superintendent of Police to remove or cause to be removed any sign or advertisement which is so placed in his opinion as to obscure any traffic sign from view or any sign or advertisement which in his opinion is so similar in appearance to a traffic sign as to be misleading or which in his opinion is likely to distract the attention or concentration of the driver.

(5) No person shall wilfully remove, alter, deface, or in any way tamper with, any traffic signs placed or erected under this section.

(6) If any person accidentally causes such damage to a traffic sign as renders it useless for the purpose for which it is placed or erected under this section, he shall report the circumstances of the occurrence to a police officer or at a police station as soon as possible, and in any case within twenty four hours of the occurrence.

(7) For the purpose of bringing the signs set forth in ¹[the First Schedule] in conformity with any International Convention relating to motor traffic to which the Central Government is for the time being a party, the Central Government may, by notification in the Official Gazette, make any addition or alteration to any such sign and on the issue of any such notification, ¹[the First Schedule] shall be deemed to be amended accordingly.

117. Parking places and halting stations.

The State Government or any authority authorised in this behalf by the State Government may, in consultation with the local authority having jurisdiction in the area concerned, determine places at which motor vehicles may stand either indefinitely or for a specified period of time, and may determine the places at which public service vehicles may stop for a longer time than is necessary for the taking up and setting down of passengers.

1. Subs, by Act 54 of 1994, sec. 36, for "the Schedule" (w.e.f. 14-11-1994).

118. Driving regulations.

The Central Government may, by notification in the Official Gazette, make regulations for the driving of motor vehicles.

119. Duty to obey traffic signs.

(1) Every driver of a motor vehicle shall drive the vehicle in conformity with any indication given by mandatory traffic sign and in conformity with the driving regulations made by the Central Government, and shall comply with all directions given to him by any police officer for the time being engaged in the regulation of traffic in any public place.

(2) In this section "mandatory traffic sign" means a traffic sign included in Part A of ¹[The First Schedule], or any traffic sign of similar form (that is to say, consisting of or including a circular disc displaying a device, word or figure and having a red ground or border) placed or erected for the purpose of regulating motor vehicle traffic under sub-section (1) of section 116.

120. Vehicles with left hand control.

No person shall drive or cause or allow to be driven in any public place any motor vehicle with a left-hand steering control unless it is equipped with a mechanical or electrical signalling device of a prescribed nature and in working order.

121. Signals and signalling devices.

The driver of a motor vehicle shall make such signals and on such occasions as may be prescribed by the Central Government:

Provided that the signal of an intention to turn to the right or left or to stop-

- (a) in the case of a motor vehicle with a right-hand steering control, may be given by a mechanical or electrical device of a prescribed nature affixed to the vehicle; and
- (b) in the case of a motor vehicle with a left hand steering control, shall be given by a mechanical or electrical device of a prescribed nature affixed to the vehicle:

Provided further that the State Government may, having regard to the width and condition of the roads in any area or route, by notification in the Official Gazette, exempt subject to such conditions as may be specified therein any motor vehicle or class or description of motor vehicles from the operation of this section for the purpose of plying in that area or route.

¹. Subs, by Act 54 of 1994, sec. 36, for "the Schedule" (w.e.f. 14-11-1994).

121. Signals and signalling devices.

The driver of a motor vehicle shall make such signals and on such occasions as may be prescribed by the Central Government:

Provided that the signal of an intention to turn to the right or left or to stop-

- (a) in the case of a motor vehicle with a right-hand steering control, may be given by a mechanical or electrical device of a prescribed nature affixed to the vehicle; and
- (b) in the case of a motor vehicle with a left hand steering control, shall be given by a mechanical or electrical device of a prescribed nature affixed to the vehicle:

Provided further that the State Government may, having regard to the width and condition of the roads in any area or route, by notification in the Official Gazette, exempt subject to such conditions as may be specified therein any motor vehicle or class or description of motor vehicles from the operation of this section for the purpose of plying in that area or route.

122. Leaving vehicle in dangerous position.

No person in charge of a motor vehicle shall cause or allow the vehicle or any trailer to be abandoned or to remain at rest on any public place in such a position or in such a condition or in such circumstances as to cause or likely to cause danger, obstruction or undue inconvenience to other users of the public place or to the passengers.

123. Riding on running board, etc.

- (1) No person driving or in charge of a motor vehicle shall carry any person or permit any person to be carried on the running board or otherwise than within the body of the vehicle.
- (2) No person shall travel on the running board or on the top or on the bonnet of a motor vehicle.

124. Prohibition against travelling without pass or ticket.

No person shall enter or remain in any stage carriage for the purposes of travelling therein unless he has with him a proper pass or ticket:

Provided that where arrangements for the supply of tickets are made in the stage carriage by which a person has to travel, a person may enter such stage carriage but as soon as may be after his entry therein, he shall make the payment of his fare to the conductor or the driver who performs the functions of a conductor and obtain from such conductor or driver, as the case may be, a ticket for his journey.

Explanation.-In this section,-

- (a) "pass" means a duty, privilege or courtesy pass entitling the person to whom it is given to travel in a stage carriage gratuitously and includes a pass issued on payment for travel in a stage carriage for the period specified therein;

- (b) "ticket" includes a single ticket, a return ticket or a season ticket.

125. Obstruction of driver.

No person driving a motor vehicle shall allow any person to stand or sit or to place anything in such a manner or position as to hamper the driver in his control of the vehicle.

126. Stationary vehicles.

No person driving or in charge of a motor vehicle shall cause or allow the vehicle to remain stationary in any public place, unless there is in the driver's seat a person duly licensed to drive the vehicle or unless the mechanism has been stopped and a brake or brakes applied or such other measures taken as to ensure that the vehicle cannot accidentally be put in motion in the absence of the driver.

127. Removal of motor vehicles abandoned or left unattended on a public place.

¹[(1) Where any motor vehicle is abandoned or left unattended on a public place for ten hours or more or is parked in a place where parking is legally prohibited, its removal by a towing service or its immobilisation by any means including wheel clamping may be authorised by a police officer in uniform having jurisdiction.]

(2) Where an abandoned, unattended, wrecked, burnt or partially dismantled vehicle is creating a traffic hazard, because of its position in relation to the ²[public place], or its physical appearance is causing the impediment to the traffic, its immediate removal from the ²[public place] by a towing service may be authorised by a police officer having jurisdiction.

(3) Where a vehicle is authorised to be removed under sub-section (1) or subsection (2) by a police officer, the owner of the vehicle shall be responsible for all towing costs, besides any other penalty.

128. Safety measures for drivers and pillion riders.

(1) No driver of a two-wheeled motor cycle shall carry more than one person in addition to himself on the motor cycle and no such person shall be carried otherwise than sitting on a proper seat securely fixed to the motor cycle behind the driver's seat with appropriate safety measures.

(2) In addition to the safety measures mentioned in sub-section (1), the Central Government may, prescribe other safety measures for the drivers of two-wheeled motor cycles and pillion riders thereon.

1. Subs. by Act 54 of 1994, sec. 37, for sub-section (1) (w.e.f. 14-11-1994).

2. Subs. by Act 54 of 1994, sec. 37, for "highway" (w.e.f. 14-11-1994).

129. Wearing of protective headgear.

Every person driving or riding (otherwise than in a side car, on a motor cycle of any class or description) shall, while in a public place, wear¹[protective headgear conforming to the standards of Bureau of Indian Standards]:

Provided that the provisions of this sections shall not apply to a person who is a Sikh, if he is, while driving or riding on the motor cycle, in a public place, wearing a turban:

Provided further that the State Government may, by such rules, provide for such exceptions as it may think fit.

Explanation.-"Protective headgear" means a helmet which,-

- (a) by virtue of its shape, material and construction, could reasonably be expected to afford to the person driving or riding on a motor cycle a degree or protection from injury in the event of an accident; and
- (b) is securely fastened to the head of the wearer by means of straps or other fastenings provided on the headgear.

130. Duty to produce licence and certificate of registration.

(1) The driver of a motor vehicle in any public place shall, on demand by any police officer in uniform, produce his licence for examination:

Provided that the driver may, if his licence has been submitted to, or has been seized by, any officer or authority under this or any other Act, produce in lieu of the licence a receipt or other acknowledgment issued by such officer or authority in respect thereof and thereafter produce the licence within such period, in such manner as the Central Government may prescribe to the police officer making the demand.

²[(2) The conductor, if any, of a motor vehicle on any public place shall on demand by any officer of the Motor Vehicles Department authorised in this behalf, produce the licence for examination.]

³[(3) The owner of a motor vehicle (other than a vehicle registered under section 60), or in his absence the driver or other person in charge of the vehicle, shall, on demand by a registering authority or any other officer of the Motor Vehicles Department duly authorised in this behalf, produce the certificate of insurance of the vehicle and, where the vehicle is a transport vehicle, also the certificate of fitness referred to in section 56 and the permit; and if any or all of the certificates or the permit are not in his possession, he shall, within fifteen days from the date of demand, submit photo copies of the same, duly attested in person or send the same by registered post to the officer who demanded it.

1.Subs. by Act 54 of 1994, sec. 38, for certain words (w.e.f. 14-11-1994).

2. Subs. by Act 54 of 1994, sec. 39, for sub-section (2) (w.e.f. 14-11-1994).

3. Subs. by Act 54 of 1994, sec. 39, for sub-section (3) (w.e.f. 14-11-1994).

Explanation.-For the purposes of this sub-section, "certificate" of insurance" means the certificate issued under sub-section (3) of section 147.]

(4) If the licence referred to in sub-section (2) or the certificates or permit referred to in sub-section (3), as the case may be, are not at the time in the possession of the person to whom demand is made, it shall be a sufficient compliance with this section if such person produces the licence or certificates or permit within such period in such manner as the Central Government may prescribe, to the police officer or authority making the demand:

Provided that, except to such extent and with such modifications as may be prescribed, the provisions of this sub-section shall not apply to any person required to produce the certificate of registration or the certificate of fitness of a transport vehicle.

131. Duty of the driver to take certain precautions at unguarded railway level crossings.

Every driver of a motor vehicle at the approach of any unguarded railway level crossing shall cause the vehicle to stop and the driver of the vehicle shall cause the conductor or cleaner or attendant or any other person in the vehicle to walk up to the level crossing and ensure that no train or trolley is approaching from either side and then pilot the motor vehicle across such level crossing, and where no conductor or cleaner or attendant or any other person is available in the vehicle, the driver of the vehicle shall get down from the vehicle himself to ensure that no train or trolley is approaching from either side before the railway track is crossed.

132. Duty of driver to stop in certain cases.

(1) The driver of a motor vehicle shall cause the vehicle to stop and remain stationary so long as ¹[may for such reasonable time as may be necessary, but not exceeding twenty-four hours],-

²[(a) when required to do so by any police officer not below the rank of a Sub-Inspector in uniform, in the event of the vehicle being involved in the occurrence of an accident to a person, animal or vehicle or of damage to property, or]

(b) when required to do so by any person in charge of an animal if such person apprehends that the animal is, or being alarmed by the vehicle will become, unmanageable,

³[***]

and he shall give his name and address and the name and address of the owner of the vehicle to any person affected by any such accident or damage who demands it provided such person also furnishes his name and address.

(2) The driver of a motor vehicle shall, on demand by a person giving his own name and address and alleging that the driver has committed an offence punishable under section 184 given his name and address to that person.

(3) In this section the expression "animal" means any horse, cattle, elephant, camel, ass, mule, sheep or goat.

1. Subs. by Act 54 of 1994, sec. 40, for "may reasonably be necessary" (w.e.f. 14-11-1994).

2. Subs. by Act 54 of 1994, sec. 40, for clause (a) (w.e.f. 14-11-1994).

3. Clause (c) omitted by Act 54 of 1994, sec. 40 (w.e.f. 14-11-1994).

133. Duty of owner of motor vehicle to give information.

The owner of a motor vehicle, the driver or conductor of which is accused of any offence under this Act shall, on the demand of any police officer authorised in this behalf by the State Government, give all information regarding the name and address of, and the licence held by, the driver or conductor which is in his possession or could by reasonable diligence be ascertained by him.

134. Duty of driver in case of accident and injury to a person.

When any person is injured or any property of a third party is damaged, as a result of an accident in which a motor vehicle is involved, the driver of the vehicle or other person in charge of the vehicle shall-

- (a) unless it is not practicable to do so on account of mob fury or any other reason beyond his control, take all reasonable steps to secure medical attention for the injured person, ¹[by conveying him to the nearest medical practitioner or hospital, and it shall be the duty of every registered medical practitioner or the doctor on the duty in the hospital immediately to attend to the injured person and render medical aid or treatment without waiting for any procedural formalities], unless the injured person or his guardian, in case he is a minor, desires otherwise;
- (b) give on demand by a police officer any information required by him, or, if no police officer is present, report the circumstances of the occurrence, including the circumstances, if any, for not taking reasonable steps to secure medical attention as required under clause (a), at the nearest police station as soon as possible, and in any case within twenty-four hours of the occurrence;
- ²[(c) give the following information in writing to the insurer, who has issued the certificates of insurance, about the occurrence of the accident, namely:-
 - (i) insurance policy number and period of its validity;
 - (ii) date, time and place of accident;
 - (iii) particulars of the persons injured or killed in the accident;
 - (iv) name of the driver and the particulars of his driving licence.

Explanation.-For the purposes of this section the expression "driver" includes the owner of the vehicle.]

1. Subs, by Act 54 of 1994, sec. 41, of "and, if necessary, convey him to the nearest hospital" 2. Ins. by Act 54 of 1994, sec. 41 (w.e.f. 14-11-1994).

135. Schemes to be framed for the investigation of accident cases and wayside amenities, etc.

(1) The State Government may, by notification in the Official Gazette, make one or more schemes to provide for-

- (a) an in depth study on causes and analysis of motor vehicle accidents;
- (b) wayside amenities on highways;
- (c) traffic aid posts on highways; and
- (d) truck parking complexes along highways.

(2) Every scheme made under this section by any State Government shall be laid, as soon as may be after it is made, before the State Legislature.

136. Inspection of vehicle involved in accident.

When any accident occurs in which a motor vehicle is involved, any person authorised in this behalf by the State Government may, on production if so required of his authority, inspect the vehicle and for that purpose may enter at any reasonable time any premises where the vehicle may be, and may remove the vehicle for examination:

Provided that the place to which the vehicle is so removed shall be intimated to the owner of the vehicle and the vehicle shall be returned¹[after completion of the formalities to the owner, driver or the person in charge of the vehicle within twenty-four hours].

137. Power of Central Government to make rules.

The Central Government may make rules to provide for all or any of the following matters, namely:-

- (a) the occasions on which signals shall be made by drivers of motor vehicles and such signals under section 121;
- (b) the manner in which the licences and certificates may be produced to the police officer under section 130.

138. Power of State Government to make rules.

(1) The State Government may make rules for the purpose of carrying into effect the provisions of this Chapter other than the matters specified in section 137.

(2) Without prejudice to the generality of the foregoing power, such rules may provide for-

1. Subs. by Act 54 of 1994, sec. 42, for "without unnecessary delay" (w.e.f. 14-11-1994).

- (a) the removal and the safe custody of vehicles including their loads which have broken down or which have been left standing or have been abandoned on road;
- (b) the installation and use of weighing devices;
- (c) the maintenance and management of wayside amenities complexes;
- (d) the exemption from all or any of the provisions of this Chapter of fire brigade vehicles, ambulances and other special classes or descriptions of vehicle, subject to such conditions as may be prescribed;
- (e) the maintenance and management of parking places and stands and the fees, if any, which may be charged for their use;
- (f) prohibiting the driving downhill of a motor vehicle with the gear disengaged either generally or in a specified place;
- (g) prohibiting the taking hold of or mounting of a motor vehicle in motion;
- (h) prohibiting the use of foot-paths or pavements by motor vehicles;
- (i) generally, the prevention of danger, injury or annoyance to the public or any person, or of danger or injury to property or of obstruction to traffic; and
- (j) any other matter which is to be, or may be, prescribed.

CHAPTER IX
MOTOR VEHICLES TEMPORARILY LEAVING OR VISITING INDIA

139. Power of Central Government to make rules.

(1) The Central Government may, by notification in the Official Gazette, make rules for all or any of the following purposes, namely:-

- (a) the grant and authentication of travelling passes, certificates or authorisations to persons temporarily taking motor vehicles out of India to any place outside India or to persons temporarily proceeding out of India to any place outside India and desiring to drive a motor vehicle during their absence from India;
- (b) prescribing the conditions subject to which motor vehicles brought temporarily into India from outside India by persons intending to make a temporary stay in India may be possessed and used in India; and
- (c) prescribing the conditions subject to which persons entering India from any place outside India for a temporary stay in India may drive motor vehicles in India.

(2) For the purpose of facilitating and regulating the services of motor vehicles operating between India and any other country under any reciprocal arrangement and carrying passengers or goods or both by road for hire or reward, the Central Government may, by notification in the Official Gazette, make rules with respect to all or any of the following matters, namely:-

- (a) the conditions subject to which motor vehicles carrying on such services may be brought into India from outside India and possessed and used in India;
- (b) the conditions subject to which motor vehicles may be taken from any place in India to any place outside India;
- (c) the conditions subject to which persons employed as drivers and conductors of such motor vehicles may enter or leave India;
- (d) the grant and authentication of travelling passes, certificates or authorisations to persons employed as drivers and conductors of such motor vehicles;
- (e) the particulars (other than registration marks) to be exhibited by such motor vehicles and the manner in which such particulars are to be exhibited;
- (f) the use of trailers with such motor vehicles;
- (g) the exemption of such motor vehicles and their drivers and conductors from all or any or the provisions of this Act [other than those referred to in sub-section (4)] of the rules made thereunder;
- (h) the identification of the drivers and conductors of such motor vehicles;

- (i) the replacement of the travelling passes, certificates or authorisations, permits, licences or any other prescribed documents lost or defaced, on payment of such fee as may be prescribed;
 - (j) the exemption from the provisions of such laws as relate to customs, police or health with a view to facilitate such road transport services;
 - (k) any other matter which is to be, or may be, prescribed.
- (3) No rule made under this section shall operate to confer on any person any immunity in any State from the payment of any tax levied in that State on motor vehicles or their users.
- (4) Nothing in this Act or in any rule made thereunder by a State Government relating to-
- (a) the registration and identification of motor vehicles, or
 - (b) the requirements as to construction, maintenance and equipment of motor vehicles, or
 - (c) the licensing and the qualifications of drivers and conductors of motor vehicles, shall
- apply-
- (i) to any motor vehicle to which or to any driver of a motor vehicle to whom any rules made under clause (b) or clause (c) of sub-section (1) or under sub-section (2) apply; or
 - (ii) to any conductor of a motor vehicle to whom any rules made under sub-section (2) apply.

CHAPTER X
LIABILITY WITHOUT FAULT IN CERTAIN CASES

140. Liability to pay compensation in certain cases on the principle of no fault.

(1) Where death or permanent disablement of any person has resulted I from an accident arising out of the use of a motor vehicle or motor vehicles, the 1 owner of the vehicle shall, or, as the case may be, the owners of the vehicles shall, I jointly and severally, be liable to pay compensation in respect of such death or disablement in accordance with the provisions of this section.

(2) The amount of compensation which shall be payable under sub-section (1) in respect of the death of any person shall be a fixed sum of ¹[fifty thousand rupees] and the amount of compensation payable under that sub-section in respect of the permanent disablement of any person shall be a fixed sum of ²[twenty-five thousand rupees].

(3) In any claim for compensation under sub-section (1), the claimant shall not be required to plead and establish that the death or permanent disablement in respect of which the claim has been made was due to any wrongful act, neglect or default of the owner or owners of the vehicle or vehicles concerned or of any other person.

(4) A claim for compensation under sub-section (1) shall not be defeated by reason of any wrongful act, neglect or default of the person in respect of whose death or permanent disablement the claim has been made nor shall the quantum of compensation recoverable in respect of such death or permanent disablement be reduced on the basis of the share of such person in the responsibility for such death or permanent disablement.

³[(5) Notwithstanding anything contained in sub-section (2) regarding death or bodily injury to any person, for which the owner of the vehicle is liable to give compensation for relief, he is also liable to pay compensation under any other law for the time being in force:

Provided that the amount of such compensation to be given under any other law shall be reduced from the amount of compensation payable under this section or under section 163A.]

141. Provisions as to other right to claim compensation for death or permanent disablement.

(1) The right to claim compensation under section 140 in respect of death or permanent disablement of any person shall be in addition to ⁴[any other right, except the right to claim under the scheme referred to in section 163A (such other right hereafter] in this section referred to as the right on the principle of fault) to claim compensation in respect thereof under any other provision of this Act or of any other law for the time being in force].

1. Subs. by Act 54 of 1994, sec. 43, for "twenty-five thousand rupees" (w.e.f. 14-11-1994).

2. Sub, by Act 54 of 1994 sec. 43, for "twelve thousand rupees" (w.e.f. 14-11-1994).

3. Ins. by Act 54 of 1994, sec. 43 (w.e.f. 14-11-1994).

4. Subs. by Act 54 of 1994, sec. 44, for "any other right (hereafter" (w.e.f. 14-11-1994).

(2) A claim for compensation under section 140 in respect of death or permanent disablement of any person shall be disposed of as expeditiously as possible and where compensation is claimed in respect of such death or permanent disablement under section 140 and also in pursuance of any right on the principle of fault, the claim for compensation under section 140 shall be disposed of as aforesaid in the first place.

(3) Notwithstanding anything contained in sub-section (1), where in respect of the death or permanent disablement of any person, the person liable to pay compensation under section 140 is also liable to pay compensation in accordance with the right on the principle of fault, the person so liable shall pay the first- mentioned compensation and-

- (a) if the amount of the first-mentioned compensation is less than the amount of the second-mentioned compensation, he shall be liable to pay (in addition to the first-mentioned compensation) only so much of the second-mentioned compensation as is equal to the amount by which it exceeds the first mentioned compensation;
- (b) if the amount of the first-mentioned compensation is equal to or more than the amount of the second-mentioned compensation, he shall not be liable to pay the second-mentioned compensation.

142. Permanent disablement.

For the purposes of this Chapter, permanent disablement of a person shall be deemed to have resulted from an accident of the nature referred to in sub-section (1) of section 140 if such person has suffered by reason of the accident, any injury or injuries involving:-

- (a) permanent privation of the sight of either eye or the hearing of either ear, or privation of any member or joint; or
- (b) destruction or permanent impairing of the powers of any member or joint; or
- (c) permanent disfiguration of the head or face.

143. Applicability of Chapter to certain claims under Act 8 of 1923.

The provisions of this Chapter shall also apply in relation to any claim for compensation in respect of death or permanent disablement of any person under the Workmen's Compensation Act, 1923 resulting from an accident of the nature referred to in sub-section (1) of section 140 and for this purpose, the said provisions shall, with necessary modifications, be deemed to form part of that Act.

144. Overriding effect.

The provisions of this Chapter shall have effect notwithstanding anything contained in any other provision of this Act or of any other law for the time being in force.

CHAPTER XI

INSURANCE OF MOTOR VEHICLES AGAINST THIRD PARTY RISKS

145. Definitions.

In this Chapter,-

- (a) "authorised insurer" means an insurer for the time being carrying on general insurance business in India under the General Insurance Business (Nationalisation) Act, 1972, and any Government insurance fund authorised to do general insurance business under that Act;
- (b) "certificate of insurance" means a certificate issued by an authorised insurer in pursuance of sub-section (3) of section 147 and includes a cover note complying with such requirements as may be prescribed, and where more than one certificate has been issued in connection with a policy, or where a copy of a certificate has been issued, all those certificates or that copy, as the case may be;
- (c) "liability", wherever used in relation to the death of or bodily injury to any person, includes liability in respect thereof under section 140;
- (d) "policy of insurance" includes "certificate of insurance";
- (e) "property" includes goods carried in the motor vehicle, roads, bridges, culverts, causeways, trees, posts and mile-stones;
- (f) "reciprocating country" means any such country as may on the basis of reciprocity be notified by the Central Government in the Official Gazette to be a reciprocating country for the purposes of this Chapter;
- (g) "third party" includes the Government.

146. Necessity for insurance against third party risk.

(1) No person shall use, except as a passenger, or cause or allow any other person to use, a motor vehicle in a public place, unless there is in force in relation to the use of the vehicle by that person or that other person, as the case may be, a policy of insurance complying with the requirements of this Chapter:

¹[Provided that in the case of a vehicle carrying, or meant to carry, dangerous or hazardous goods, there shall also be a policy of insurance under the Public Liability Insurance Act, 1991 (6 of 1991).]

Explanation.-A person driving a motor vehicle merely as a paid employee, while there is in force in relation to the use of the vehicle no such policy as is required by this sub-section, shall not be deemed to act in contravention of the sub-section unless he knows or has reason to believe that there is no such policy in force.

1. Ins. by Act 54 of 1994, sec. 45 (w.e.f. 14-11-1994).

(2) Sub-section (1) shall not apply to any vehicle owned by the Central Government or a State Government and used for Government purposes unconnected with any commercial enterprise.

(3) The appropriate Government may, by order, exempt from the operation of sub-section (1) any vehicle owned by any of the following authorities, namely:-

- (a) the Central Government or a State Government, if the vehicle is used for Government purposes connected with any commercial enterprise;
- (b) any local authority;
- (c) any State transport undertaking:

Provided that no such order shall be made in relation to any such authority unless a fund has been established and is maintained by that authority in accordance with the rules made in that behalf under this Act for meeting any liability arising out of the use of any vehicle of that authority which that authority or any person in its employment may incur to third parties.

Explanation.-For the purposes of this sub-section, "appropriate Government" means the Central Government or a State Government, as the case may be, and-

- (i) in relation to any corporation or company owned by the Central Government or any State Government, means the Central Government or that State Government;
- (ii) in relation to any corporation or company owned by the Central Government and one or more State Governments, means the Central Government;
- (iii) in relation to any other State transport undertaking or any local authority, means that Government which has control over that undertaking or authority.

147. Requirements of policies and limits of liability.

(1) In order to comply with the requirements of this Chapter, a policy of insurance must be a policy which-

- (a) is issued by a person who is an authorised insurer; or
- (b) insurer the person or classes of persons specified in the policy to the extent specified in sub-section (2)-
 - (i) against any liability which may be incurred by him in respect of the death of or bodily ¹[injury to any person, including owner of the goods or his authorised representative carried in the vehicle] or damage to any property of a third party caused by or arising out of the use of the vehicle in a public place;
 - (ii) against the death of or bodily injury to any passenger of a public service vehicle caused by or arising out of the use of the vehicle in a public place:

1. Subs. by Act 54 of 1994, sec. 46, for "injury to any person" (w.e.f. 14-11-1994).

Provided that a policy shall not be required-

- (i) to cover liability in respect of the death, arising out of and in the course of his employment, of the employee of a person insured by the policy or in respect of bodily injury sustained by such an employee arising out of and in the course of his employment other than a liability arising under the Workmen's Compensation Act, 1923 (8 of 1923) in respect of the death of, or bodily injury to, any such employee-
 - (a) engaged in driving the vehicle, or
 - (b) if it is a public service vehicle engaged as conductor of the vehicle or in examining tickets on the vehicle, or
 - (c) if it is a goods carriage, being carried in the vehicle, or
- (ii) to cover any contractual liability.

Explanation.-For the removal of doubts, it is hereby declared that the death of or bodily injury to any person or damage to any property of a third party shall be deemed to have been caused by or to have arisen out of, the use of a vehicle in a public place notwithstanding that the person who is dead or injured or the property which is damaged was not in a public place at the time of the accident, if the act or omission which led to the accident occurred in a public place.

(2) Subject to the proviso to sub-section (1), a policy of insurance referred to in sub-section (1), shall cover any liability incurred in respect of any accident, up to the following limits, namely:-

- (a) save as provided in clause (b), the amount of liability incurred;
- (b) in respect of damage to any property of a third party, a limit of rupees six thousand:

Provided that any policy of insurance issued with any limited liability and in force, immediately before the commencement of this Act, shall continue to be effective for a period of four months after such commencement or till the date of expiry of such policy whichever is earlier.

(3) A policy shall be of no effect for the purposes of this Chapter unless and until there is issued by the insurer in favour of the person by whom the policy is effected a certificate of insurance in the prescribed form and containing the prescribed particulars of any condition subject to which the policy is issued and of any other prescribed matters; and different forms, particulars and matters may be prescribed in different cases.

(4) Where a cover note issued by the insurer under the provisions of this Chapter or the rules made thereunder is not followed by a policy of insurance within the prescribed time, the insurer shall, within seven days of the expiry of the period of the validity of the cover note, notify the fact to the registering authority in whose records the vehicle to which the cover note relates has been registered or to such other authority as the State Government may prescribe.

(5) Notwithstanding anything contained in any law for the time being in force, an insurer issuing a policy of insurance under this section shall be liable to indemnify the person or classes of persons specified in the policy in respect of any liability which the policy purports to cover in the case of that person or those classes of persons.

148. Validity of policies of insurance issued in reciprocating countries.

Where, in pursuance of an arrangement between India and any reciprocating country, the motor vehicle registered in the reciprocating country operates on any route or within any area common to the two countries and there is in force in relation to the use of the vehicle in the reciprocating country, a policy of insurance complying with the requirements of the law of insurance in force in that country, then, notwithstanding anything contained in section 147 but subject to any rules which may be made under section 164, such policy of insurance shall be effective throughout the route or area in respect of which, the arrangement has been made, as if the policy of insurance had complied with the requirements of this Chapter.

149. Duty of insurers to satisfy judgments and awards against persons insured in respect of third party risks.

(1) If, after a certificate of insurance has been issued under sub-section (3) of section 147 in favour of the person by whom a policy has been effected, judgment or award in respect of any such liability as is required to be covered by a policy under clause (b) of sub-section (1) of section 147 (being a liability covered by the terms of the policy) ¹[for under the provisions of section 163A] is obtained against any person insured by the policy, then, notwithstanding that the insurer may be entitled to avoid or cancel or may have avoided or cancelled the policy, the insurer shall, subject to the provisions of this section, pay to the person entitled to the benefit of the decree any sum not exceeding the sum assured payable thereunder, as if he were the judgment debtor, in respect of the liability, together with any amount payable in respect of costs and any sum payable in respect of interest on that sum by virtue of any enactment relating to interest on judgments.

(2) No sum shall be payable by an insurer under sub-section (1) in respect of any judgment or award unless, before the commencement of the proceedings in which the judgment or award is given the insurer had notice through the Court or, as the case may be, the Claims Tribunal of the bringing of the proceedings, or in respect of such judgment or award so long as execution is stayed thereon pending an appeal; and an insurer to whom notice of the bringing of any such proceedings is so given shall be entitled to be made a party thereto and to defend the action on any of the following grounds, namely:-

- (a) that there has been a breach of a specified condition of the policy, being one of the following conditions, namely:-
 - (i) a condition excluding the use of the vehicle-
 - (a) for hire or reward, where the vehicle is on the date of the contract of insurance a vehicle not covered by a permit to ply for hire or reward, or
 - (b) for organised racing and speed testing, or

¹ Ins. by Act 54 of 1994, sec. 47 (w.e.f. 14-11-1994).

(c) for a purpose not allowed by the permit under which the vehicle is used, where the vehicle is a transport vehicle, or

(d) without side-car being attached where the vehicle is a motor cycle; or

(ii) a condition excluding driving by a named person or persons or by any person who is not duly licensed, or by any person who has been disqualified for holding or obtaining a driving licence during the period of disqualification; or

(iii) a condition excluding liability for injury caused or contributed to by conditions of war, civil war, riot or civil commotion; or

(b) that the policy is void on the ground that it was obtained by the nondisclosure of a material fact or by a representation of fact which was false in some material particular.

(3) Where any such judgment as is referred to in sub-section (1) is obtained from a Court in a reciprocating country and in the case of a foreign judgment is, by virtue of the provisions of section 13 of the Code of Civil Procedure, 1908 (5 of 1908) conclusive as to any matter adjudicated upon by it, the insurer (being an insurer registered under the Insurance Act, 1938 (4 of 1938) and whether or not he is registered under the corresponding law of the reciprocating country) shall be liable to the person entitled to the benefit of the decree in the manner and to the extent specified in sub-section (1), as if the judgment were given by a Court in India:

Provided that no sum shall be payable by the insurer in respect of any such judgment unless, before the commencement of the proceedings in which the judgment is given, the insurer had notice through the Court concerned of the bringing of the proceedings and the insurer to whom notice is so given is entitled to be made a party to the proceedings and to defend the action on grounds similar to those specified in sub-section (2).

(4) Where a certificate of insurance has been issued under sub-section (3) of section 147 to the person by whom a policy has been effected, so much of the policy as purports to restrict the insurance of the persons insured thereby by reference to any condition other than those in clause (b) of sub-section (2) shall, as respects such liabilities as are required to be covered by a policy under clause (b) of sub-section (1) of section 147, be of no effect:

Provided that any sum paid by the insurer in or towards the discharge of any liability of any person which is covered by the policy by virtue only of this subsection shall be recoverable by the insurer from that person.

(5) If the amount which an insurer becomes liable under this section to pay in respect of a liability incurred by a person insured by a policy exceeds the amount for which the insurer would apart from the provisions of this section be liable under the policy in respect of that liability, the insurer shall be entitled to recover the excess from that person.

(6) In this section the expression "material fact" and "material particular" means, respectively a fact or particular of such a nature as to influence the judgment of a prudent insurer in determining whether he will take the risk and, if so, at what premium and on what conditions, and the expression "liability covered by the terms of the policy" means a liability

which is covered by the policy or which would be so covered but for the fact that the insurer is entitled to avoid or cancel or has avoided or cancelled the policy.

(7) No insurer to whom the notice referred to in sub-section (2) or sub-section (3) has been given shall be entitled to avoid his liability to any person entitled to the benefit of any such judgment or award as is referred to in sub-section (1) or in such judgment as is referred to in sub-section (3) otherwise than in the manner provided for in sub-section (2) or in the corresponding law of the reciprocating country, as the case may be.

Explanation.-For the purposes of this section, "Claims Tribunal" means a Claims Tribunal constituted under section 165 and "award" means an award made by that Tribunal under section 168.

150. Rights of third parties against insurers on insolvency of the insured.

(1) Where under any contract of insurance effected in accordance with the provisions of this Chapter, a person is insured against liabilities which he may incur to third parties, then-

- (a) in the event of the person becoming insolvent or making a composition or arrangement with his creditors, or
- (b) where the insured person is a company, in the event of a winding-up order being made or a resolution for a voluntary winding-up being passed with respect to the company or of a receiver or manager of the company's business or undertaking being duly appointed, or of possession being taken by or on behalf of the holders of any debentures secured by a floating charge of any property comprised in or subject to the charge,

if, either before or after that event, any such liability is incurred by the insured person, his rights against the insurer under the contract in respect of the liability shall, notwithstanding anything to the contrary in any provision of law, be transferred to and vest in the third party to whom the liability was so incurred.

(2) Where an order for the administration of the estate of a deceased debtor is made according to the law of insolvency, then, if any debt provable in insolvency is owing by the deceased in respect of a liability to a third party against which he was insured under a contract of insurance in accordance with the provisions of this Chapter, the deceased debtor's rights against the insurer in respect of that liability shall, notwithstanding anything to the contrary in any provision of law, be transferred to and vest in the person to whom the debt is owing.

(3) Any condition in a policy issued for the purposes of this Chapter purporting either directly or indirectly to avoid the policy or to alter the rights of the parties thereunder upon the happening to the insured person of any of the events specified in clause (a) or clause (b) of sub-section (1) or upon the making of an order for the administration of the estate of a deceased debtor according to the law of insolvency shall be of no effect.

(4) Upon a transfer under sub-section (1) or sub-section (2), the insurer shall be under the same liability to the third party as he would have been to the insured person, but-

- (a) if the liability of the insurer to the insured person exceeds the liability of the insured person to the third party, nothing in this Chapter shall affect the rights of the insured person against the insurer in respect of the excess, and
- (b) if the liability of the insurer to the insured person is less than the liability of the insured person to the third party, nothing in this Chapter shall affect the rights of the third party against the insured person in respect of the balance.

151. Duty to give information as to insurance.

No person against whom a claim is made in respect of any liability referred to in clause (b) of section 147 shall on demand by or on behalf of the person making the claim refuse to state whether or not he was insured in respect of that liability by any policy issued under the provisions of this Chapter, or would have been so insured if the insurer had not avoided or cancelled the policy, nor shall he refuse, if he was or would have been so insured, to give such particulars with respect to that policy as were specified in the certificate of insurance issued in respect thereof.

(2) In the event of any person becoming insolvent or making a composition or arrangement with his creditors or in the event of an order being made for the administration of the estate of deceased person according to the law of insolvency, or in the event of a winding up order being made or a resolution for a voluntary winding-up being passed with respect to any company or of a receiver or manager of the company's business or undertaking being duly appointed or of possession being taken by or on behalf of the holders of any debentures secured by a floating charge on any property comprised in or subject to the charge, it shall be the duty of the insolvent debtor, personal representative of the deceased debtor or company, as the case may be, or the official assignee or receiver in insolvency, trustee, liquidator, receiver or manager, or person in possession of the property to give at the request of any person claiming that the insolvent debtor, deceased debtor or company is under such liability to him as is covered by the provisions of this Chapter, such information as may reasonably be required by him for the purpose of ascertaining whether any rights have been transferred to and vested in him by section 150, and for the purpose of enforcing such rights, if any; and any such contract of insurance as purports whether directly or indirectly to avoid the contract or to alter the rights of the parties thereunder upon the giving of such information in the events aforesaid, or otherwise to prohibit or prevent the giving thereof in the said events, shall be of no effect.

(3) If, from the information given to any person in pursuance of sub-section (2) or otherwise, he has reasonable ground for supposing that there have or may have been transferred to him under this Chapter rights against any particular insurer, that insurer shall be subject to the same duty as is imposed by the said sub-section on the persons therein mentioned.

(4) The duty to give the information imposed by this section shall include a duty to allow all contracts of insurance, receipts for premiums, and other relevant documents in the possession or power of the person on whom the duty is so imposed to be inspected and copies thereof to be taken.

152. Settlement between insurers and insured persons.

(1) No settlement made by an insurer in respect of any claim which might be made by a third party in respect of any liability of the nature referred to in clause (b) of sub-section (1) of section 147 shall be valid unless such third party is a party to the settlement.

(2) Where a person who is insured under a policy issued for the purposes of (his Chapter has become insolvent, or where, if such insured person is a company, a winding-up order has been made or a resolution for a voluntary winding-up has been passed with respect to the company, no agreement made between the insurer and the insured person after the liability has been incurred to a third party and after the commencement of the insolvency or winding-up, as the case may be, nor any waiver, assignment or other disposition made by or payment made to the insured person after the commencement aforesaid shall be effective to defeat the rights transferred to the third party under this Chapter, but those rights shall be the same as if no such agreement, waiver, assignment or disposition or payment has been made.

153. Saving in respect of sections 150,151 and 152.

(1) For the purposes of sections 150, 151 and 152 a reference to "liabilities to third parties" in relation to a person insured under any policy of insurance shall not include a reference to any liability of that person in the capacity of insurer under some other policy of insurance.

(2) The provisions of sections 150, 151, and 152 shall not apply where a company is wound-up voluntarily merely for the purposes of reconstruction or of an amalgamation with another company.

154. Insolvency of insured persons not to affect liability of insured or claims by third parties.

Where a certificate of insurance has been issued to the person by whom a policy has been effected, the happening in relation to any person insured by the policy of any such event as is mentioned in sub-section (1) or sub-section (2) of section 150 shall, notwithstanding anything contained in this Chapter, not affect any liability of that person of the nature referred to in clause (b) of sub-section (1) of section 147; but nothing in this section shall affect any rights against the insurer conferred under the provisions of sections 150, 151 and 152 on the person to whom the liability was incurred.

155. Effect of death on certain causes of action.

Notwithstanding anything contained in section 306 of the Indian Succession Act, 1925 (39 of 1925), the death of a person in whose favour a certificate of insurance had been issued, if it occurs I after the happening of an event which has given rise to a claim under the provisions of this Chapter, shall not be a bar to the survival of any cause of action arising out of the said event against his estate or against the insurer.

156. Effect of certificate of insurance.

When an insurer has issued a certificate of insurance in respect of a contract of insurance between the insurer and the insured person, then-

- (a) if and so long as the policy described in the certificate has not been issued by the insurer to the insured, the insurer shall, as between himself and any other person except the insured, be deemed to have issued to the insured person a policy of insurance conforming in all respects with the description and particulars stated in such certificate; and
- (b) if the insurer has issued to the insured the policy described in the certificate, but the actual terms of the policy are less favourable to persons claiming under or by virtue of the policy against the insurer either directly or through the insured than the particulars of the policy as stated in the certificate, the policy shall, as between the insurer and any other person except the insured, be deemed to be in terms conforming in all respects with the particulars stated in the said certificate.

157. Transfer of certificate of insurance.

(1) Where a person in whose favour the certificate of insurance has been issued in accordance with the provisions of this Chapter transfers to another person the ownership of the motor vehicle in respect of which such insurance was taken together with the policy of insurance relating thereto, the certificate of insurance and the policy described in the certificate shall be deemed to have been transferred in favour of the person to whom the motor vehicle is transferred with effect from the date of its transfer.

¹[Explanation.-For the removal of doubts, it is hereby declared that such deemed transfer shall include transfer of rights and liabilities of the said certificate of insurance and policy of insurance.]

(2) The transferee shall apply within fourteen days from the date of transfer in the prescribed form to the insurer for making necessary changes in regard to the fact of transfer in the certificate of insurance and the policy described in the certificate in his favour and the insurer shall make the necessary changes in the certificate and the policy of insurance in regard to the transfer of insurance.

158. Production of certain certificates, licence and permit in certain cases

(1) Any person driving a motor vehicle in any public place shall, on being so required by a police officer in uniform authorised in this behalf by the State Government, produce-

- (a) the certificate of insurance;
- (b) the certificate of registration;
- (c) the driving licence; and
- (d) in the case of a transport vehicle, also the certificate of fitness referred to in section 56 and the permit, relating to the use of the vehicle.

¹ Ins. by Act 54 of 1994, sec. 48 (w.e.f. 14-11-1994).

(2) If, where owing to the presence of a motor vehicle in a public place an accident occurs involving death or bodily injury to another person, the driver of the vehicle does not at the time produce the certificates, driving licence and permit referred to in sub-section (1) to a police officer, he shall produce the said certificates, licence and permit at the police station at which he makes the report required by section 134.

(3) No person shall be liable to conviction under sub-section (1) or subsection (2) by reason only of the failure to produce the certificate of insurance if, within seven days from the date on which its production was required under sub-section (1), or as the case may be, from the date of occurrence of the accident, he produces the certificate at such police station as may have been specified by him to the police officer who required its production or, as the case may be, to the police officer at the site of the accident or to the officer-in-charge of the police station at which he reported the accident:

Provided that except to such extent and with such modifications as may be prescribed, the provisions of this sub-section shall not apply to the driver of a transport vehicle.

(4) The owner of a motor vehicle shall give such information as he may be required by or on behalf of a police officer empowered in this behalf by the State Government to give for the purpose of determining whether the vehicle was or was not being driven in contravention of section 146 and on any occasion when the driver was required under this section to produce his certificate of insurance.

(5) In this section, the expression "produce his certificate of insurance" means produce for examination the relevant certificate of insurance or such other evidence as may be prescribed that the vehicle was not being driven in contravention of section 146.

¹[(6) As soon as any information regarding any accident involving death or bodily injury to any person is recorded or report under this section is completed by a police officer, the officer incharge of the police station shall forward a copy of the same within thirty days from the date of recording of information or, as the case may be, on completion of such report to the Claims Tribunal having jurisdiction and a copy thereof to the concerned insurer, and where a copy is made available to the owner, he shall also within thirty days of receipt of such report, forward the same to such Claims Tribunal and Insurer.]

159. Production of certificate of Insurance on application for authority to use vehicle.

A State Government may make rules requiring the owner of any motor vehicle when applying whether by payment of a tax or otherwise for authority to use the vehicle in a public place to produce such evidence as may be prescribed by those rules to the effect that either-

- (a) on the date when the authority to use the vehicle comes into operation there will be in force the necessary policy of insurance in relation to the use of the vehicle by the applicant or by other persons on his order or with his permission, or
- (b) the vehicle is a vehicle to which section 146 does not apply.

¹ Subs, by Act 54 of 1994, sec. 49, for sub-section (6) (w.e.f. 14-11-1994).

160. Duty to furnish particulars of vehicle involved in accident.

A registering authority or the officer-in-charge of a police station shall, if so required by a person who alleges that he is entitled to claim compensation in respect of an accident arising out of the use of a motor vehicle, or if so required by an insurer against whom a claim has been made in respect of any motor vehicle, furnish to that person or to that insurer, as the case may be, on payment of the prescribed fee any information at the disposal of the said authority or the said police officer relating to the identification marks and other particulars of the vehicle and the name and address of the person who was using the vehicle at the time of the accident or was injured by it and the property, if any, damaged in such form and within such time as the Central Government may prescribe.

161. Special provisions as to compensation in case of hit and run motor accident.

- (1) For the purposes of this section, section 162 and section 163-
 - (a) "grievous hurt" shall have the same meaning as in the Indian Penal Code, 1860 (45 of 1860);
 - (b) "hit and run motor accident" means an accident arising out of the use of a motor vehicle or motor vehicles the identity whereof cannot be ascertained in spite of reasonable efforts for the purpose;
 - (c) "scheme" means the scheme framed under section 163.
- (2) Notwithstanding anything contained in the General Insurance Business (Nationalisation) Act, 1972 (57 of 1972) or any other law for the time being in force or any instrument having the force of law, the General Insurance Corporation of India formed under section 9 of the said Act and the insurance companies for the time being carrying on general insurance business in India shall provide for paying in accordance with the provisions of this Act and the scheme, compensation in respect of the death of, or grievous hurt to, persons resulting from hit and run motor accidents.
- (3) Subject to the provisions of this Act and the scheme, there shall be paid as compensation-
 - (a) in respect of the death of any person resulting from a hit and run motor accident, a fixed sum of ¹[twenty-five thousand rupees];
 - (b) in respect of grievous hurt to any person resulting from a hit and run motor accident, a fixed sum of ²[twelve thousand and five hundred rupees].
- (4) The provisions of sub-section (1) of section 166 shall apply for the purpose of making applications for compensation under this section as they apply for the purpose of making applications for compensation referred to in that sub-section.

1. Subs. by Act 54 of 1994, sec. 50, for "eight thousand and five hundred rupees" (w.e.f. 14-11-1994).

2. Subs. by Act 54 of 1994, sec. 50, for "two thousand rupees" (w.e.f. 14-11-1994).

162. Refund in certain cases of compensation paid under section 161 (1).

(1) The payment of compensation in respect of the death of, or grievous hurt to, any person under section 161 shall be subject to the condition that if any compensation (hereafter in this sub-section referred to as the other compensation) or other amount in lieu of or by way of satisfaction of a claim for compensation is awarded or paid in respect of such death or grievous hurt under any other provision of this Act or any other law or otherwise so much of the other compensation or other amount aforesaid as is equal to the compensation paid under section 161 shall be refunded to the insurer.

(2) Before awarding compensation in respect of an accident involving the death of, or bodily injury to, any person arising out of the use of a motor vehicle or motor vehicles under any provision of this Act (other than section 161) or any other law, the Tribunal, Court or other authority awarding such compensation shall verify as to whether in respect of such death or bodily injury compensation has already been paid under section 161 or an application for payment of compensation is pending under that section, and such Tribunal, Court or other authority shall,-

- (a) if compensation has already been paid under section 161, direct the person liable to pay the compensation awarded by it to refund to the insurer, so much thereof as is required to be refunded in accordance with the provisions of sub-section (1);
- (b) if an application for payment of compensation is pending under section 161 forward the particulars as to the compensation awarded by it to the insurer.

Explanation.-For the purpose of this sub-section, an application for compensation under section 161 shall be deemed to be pending-

- (i) if such application has been rejected, till the date of the rejection of the application, and
- (ii) in any other case, till the date of payment of compensation in pursuance of the application.

163. Scheme for payment of compensation in case of hit and run motor accidents.

(1) The Central Government may, by notification in the Official Gazette, make a scheme¹ specifying, the manner in which the scheme shall be administered by the General Insurance Corporation, the form, manner and the time within which applications for compensation may be made, the officers or authorities to whom such applications may be made, the procedure to be followed by such officers or authorities for considering and passing orders on such applications, and all other matters connected with, or incidental to, the administration of the scheme and the payment of compensation.

1. Solatium Scheme, 1989 vide S.O. 440 (E), dated 12th June, 1989, published in the Gazette of India, Extra., Pt. II, sec. 3(ii) dated 12th June, 1989.

- (2) A scheme made under sub-section (1) may provide that-
- (a) a contravention of any provision thereof shall be punishable with imprisonment for such term as may be specified but in no case exceeding three months, or with fine which may extend to such amount as may be specified but in no case exceeding five hundred rupees or with both;
 - (b) the powers, functions or duties conferred or imposed on any officer or authority by such scheme may be delegated with the prior approval in writing of the Central Government, by such officer or authority to any other officer or authority;
 - (c) any provision of such scheme may operate with retrospective effect from a date not earlier than the date of establishment of the Solatium , Fund under the Motor Vehicles Act, 1939 (4 of 1939) as it stood immediately before the commencement of this Act:

Provided that no such retrospective effect shall be given so as to prejudicially affect the interests of any person who may be governed by such provision.

163A. Special provisions as to payment of compensation on structured formula basis.

¹[163A. Special provisions as to payment of compensation on structured formula basis.

(1) Notwithstanding anything contained in this Act or in any other law for the time being in force or instrument having the force of law, the owner of the motor vehicle or the authorised insurer shall be liable to pay in the case of death or permanent disablement due to accident arising out of the use of motor vehicle, compensation, as indicated in the Second Schedule, to the legal heirs or the victim, as the case may be.

Explanation.-For the purposes of this sub-section, "permanent disability" shall have the same meaning and extent as in the Workmen's Compensation Act, 1923 (8 of 1923).

(2) In any claim for compensation under sub-section (1), the claimant shall not be required to plead or establish that the death or permanent disablement in respect of which the claim has been made was due to any wrongful act or neglect or default of the owner of the vehicle or vehicles concerned or of any other person.

(3) The Central Government may, keeping in view the cost of living by notification in the Official Gazette, from time to time amend the Second Schedule.

¹[163B. Option to file claim in certain cases

Where a person is entitled to claim compensation under section 140 and section 163A, he shall file the claim under either of the said sections and not under both.]

1. Ins. by Act 54 of 1994, sec. 51 (w.e.f. 14-11-1994).

2. Ins. by Act 54 of 1994, sec. 51 (w.e.f. 14-11-1994).

164. Power of Central Government to make rules.

- (1) The Central Government may make rules for the purpose of carrying into effect the provisions of this Chapter, other than the matters specified in section 159.
- (2) Without prejudice to the generality of the foregoing power, such rules may provide for-
 - (a) the forms to be used for the purposes of this Chapter;
 - (b) the making of applications for and the issue of certificates of insurance;
 - (c) the issue of duplicates to replace certificates of insurance lost, destroyed or mutilated;
 - (d) the custody, production, cancellation and surrender of certificates of insurance;
 - (e) the records to be maintained by insurers of policies of insurance issued under this Chapter;
 - (f) the identification by certificates or otherwise of persons or vehicles exempted from the provisions of this Chapter;
 - (g) the furnishing of information respecting policies of insurance by insurers;
 - (h) adopting the provisions of this Chapter to vehicles brought into India by persons making only a temporary stay therein or to vehicles registered in a reciprocating country and operating on any route or within any area in India by applying those provisions with prescribed modifications;
 - (i) the form in which and the time limit within which the particulars referred to in section 160 may be furnished; and
 - (j) any other matter which is to be, or may be, prescribed.

CHAPTER XII

CLAIMS TRIBUNALS

165. Claims Tribunals.

(1) A State Government may, by notification in the Official Gazette, constitute one or more Motor Accidents Claims Tribunals (hereafter in this Chapter referred to as Claims Tribunal) for such area as may be specified in the notification for the purpose of adjudicating upon claims for compensation in respect of accidents involving the death of, or bodily injury to, persons arising out of the use of motor vehicles, or damages to any property of a third party so arising, or both.

Explanation.-For the removal of doubts, it is hereby declared that the expression "claims for compensation in respect of accidents involving the death of or bodily injury to persons arising out of the use of motor vehicles" includes claims for compensation under section 140 ¹[and section 163A].

(2) A Claims Tribunal shall consist of such number of members as the State Government may think fit to appoint and where it consists of two or more members, one of them shall be appointed as the Chairman thereof.

(3) A person shall not be qualified for appointment as a member of a Claims Tribunal unless he-

- (a) is, or has been, a Judge of a High Court, or
- (b) is, or has been a District Judge, or
- (c) is qualified for appointment as a High Court Judge ¹[or as a District Judge].

(4) Where two or more Claims Tribunals are constituted for any area, the State Government, may by general or special order, regulate the distribution of business among them.

166. Application for compensation.

(1) An application for compensation arising out of an accident of the nature specified in subsection (1) of section 165 may be made-

- (a) by the person who has sustained the injury, or
- (b) by the owner of the property, or
- (c) where death has resulted from the accident, by all or any of the legal representatives of the deceased; or
- (d) by any agent duly authorised by the person injured or all or any of the legal representatives of the deceased, as the case may be:

Provided that where all the legal representatives of the deceased have not joined in any such application for compensation, the application shall be made on behalf of or for the benefit of all the legal representatives of the deceased and the legal representatives who have not so joined, shall be impleaded as respondents to the application.

¹. Added by Act 54 of 1994, sec. 52 (w.e.f. 14-11-1994).

¹[(2) Every application under sub-section (1) shall be made, at the option of the claimant, either to the Claims Tribunal having jurisdiction over the area in which the accident occurred, or to the Claims Tribunal within the local limits of whose jurisdiction the claimant resides or carries on business or within the local limits of whose jurisdiction the defendant resides, and shall be in such form and contain such particulars as may be prescribed:

Provided that where no claim for compensation under section 140 is made in such application, the application shall contain a separate statement to that effect immediately before the signature of the applicant.]

²[***]

³[(4) The Claims Tribunal shall treat any report of accidents forwarded to it under sub-section (6) of section 158 as an application for compensation under this Act.]

167. Option regarding claims for compensation in certain cases.

Notwithstanding anything contained in the Workmen's Compensation Act, 1923 (8 of 1923) where the death of, or bodily injury to, any person gives rise to a claim for compensation under this Act and also under the Workmen's Compensation Act, 1923, the person entitled to compensation may without prejudice to the provisions of Chapter X claim such compensation under either of those Acts but not under both.

168. Award of the Claims Tribunal.

On receipt of an application for compensation made under section 166, the Claims Tribunal shall, after giving notice of the application to the insurer and after giving the parties (including the insurer) an opportunity of being heard, hold an inquiry into the claim or, as the case may be, each of the claims and, subject to the provisions of section 162 may make an award determining the amount of compensation which appears to it to be just and specifying the person or persons to whom compensation shall be paid and in making the award the Claims Tribunal shall specify the amount which shall be paid by the insurer or owner or driver of the vehicle involved in the accident or by all or any of them, as the case may be:

Provided that where such application makes a claim for compensation under section 140 in respect of the death or permanent disablement of any person, such claim and any other claim (whether made in such application or otherwise) for compensation in respect of such death or permanent disablement shall be disposed of in accordance with the provisions of Chapter X.

(2) The Claims Tribunal shall arrange to deliver copies of the award to the parties concerned expeditiously and in any case within a period of fifteen days from the date of the award.

(3) When an award is made under this section, the person who is required to pay any amount in terms of such award shall, within thirty days of the date of announcing the award by the Claims Tribunal, deposit the entire amount awarded in such manner as the Claims Tribunal may direct.

1. Subs. by Act 54 of 1994, sec. 53, for sub-section (2) (w.e.f. 14-11-1994).

2. Sub-section (3) omitted by Act 53 of 1994, sec. 53 (w.e.f. 14-11-1994).

3. Subs. by Act 54 of 1994, sec. 53, for sub-section (4) (w.e.f. 14-11-1994).

169. Procedure and powers of Claims Tribunals.

- (1) In holding any inquiry under section 168, the Claims Tribunal may, subject to any rules that may be made in this behalf, follow such summary procedure as it thinks fit.
- (2) The Claims Tribunal shall have all the powers of a Civil Court for the purpose of taking evidence on oath and of enforcing the attendance of witnesses and of compelling the discovery and production of documents and material objects and for such other purposes as may be prescribed; and the Claims Tribunal shall be deemed to be a Civil Court for all the purposes of section 195 and Chapter XXVI of the Code of Criminal Procedure, 1973 (2 of 1974).
- (3) Subject to any rules that may be made in this behalf, the Claims Tribunal may, for the purpose of adjudicating upon any claim for compensation, choose one or more persons possessing special knowledge of and matter relevant to the inquiry to assist it in holding the inquiry.

170. Impleading insurer in certain cases.

Where in the course of any inquiry, the Claims Tribunal is satisfied that-

- (a) there is collusion between the person making the claim and the person against whom the claim is made, or
- (b) the person against whom the claim is made has failed to contest the claim,

it may, for reasons to be recorded in writing, direct that the insurer who may be liable in respect of such claim, shall be impleaded as a party to the proceeding and the insurer so impleaded shall thereupon have, without prejudice to the provisions contained in sub-section

(2) of section 149, the right to contest the claim on all or any of the grounds that are available to the person against whom (he claim has been made.

171. Award of interest where any claim is allowed.

Where any Claims Tribunal allows a claim for compensation made under this Act, such Tribunal may direct that in addition to the amount of compensation simple interest shall also be paid at such rate and from such date not earlier than the date of making the claim as it may specify in this behalf.

172. Award of compensatory costs in certain cases.

- (1) Any Claims Tribunal adjudicating upon any claim for compensation under this Act, may in any case where it is satisfied for reasons to be recorded by it in writing that-
 - (a) the policy of insurance is void on the ground that it was obtained by representation of fact which was false in any material particular, or
 - (b) any party or insurer has put forward a false or vexatious claim or defence, such Tribunal may make an order for the payment, by the party who is guilty of

misrepresentation or by whom such claim or defence has been put forward of special costs by way of compensation to the insurer or, as the case may be, to the party against whom such claim or defence has been put forward.

(2) No Claims Tribunal shall pass an order for special costs under sub-section (1) for any amount exceeding one thousand rupees.

(3) No person or insurer against whom an order has been made under this section shall, by reason thereof be exempted from any criminal liability in respect of such mis-representation, claim or defence as is referred to in sub-section (1).

(4) Any amount awarded by way of compensation under this section in respect of any misrepresentation, claim or defence, shall be taken into account in any subsequent suit for damages for compensation in respect of such misrepresentation, claim or defence.

173. Appeals.

(1) Subject to the provisions of sub-section (2) any person aggrieved by an award of a Claims Tribunal may, within ninety days from the date of the award, prefer an appeal to the High Court:

Provided that no appeal by the person who is required to pay any amount in terms of such award shall be entertained by the High Court unless he has deposited with it twenty-five thousand rupees or fifty per cent, of the amount so awarded, whichever is less, in the manner directed by the High Court:

Provided further that the High Court may entertain the appeal after the expiry of the said period of ninety days, if it is satisfied that the appellant was prevented by sufficient cause from preferring the appeal in time.

(2) No appeal shall lie against any award of a Claims Tribunal if the amount in dispute in the appeal is less than ten thousand rupees.

174. Recovery of money from insurer as arrear of land revenue.

Where any amount is due from any person under an award, the Claims Tribunal may, on an application made to it by the person entitled to the amount, issue a certificate for the amount to the Collector and the Collector shall proceed to recover the same in the same manner as an arrear of land revenue.

175. Bar on jurisdiction of Civil Courts.

Where any Claims Tribunal has been constituted for any area, no Civil Court shall have jurisdiction to entertain any question relating to any claim for compensation which may be adjudicated upon by the Claims Tribunal for that area, and no injunction in respect of any action taken or to be taken by or before the Claims Tribunal in respect of the claim for compensation shall be granted by the Civil Court.

176. Power of State Government to make rules.

A State Government may make rules for the purpose of carrying into effect the provisions of sections 165 to 174, and in particular, such rules may provide for all or any of the following matters, namely:-

- (a) the form of application for claims for compensation and the particulars it may contain, and the fees, if any, to be paid in respect of such application;
- (b) the procedure to be followed by a Claims Tribunal in holding an inquiry under this Chapter;
- (c) the powers vested in a Civil Court which may be exercised by a Claims Tribunal;
- (d) the form and the manner in which and the fees (if any) on payment of which an appeal may be preferred against an award of a Claims Tribunal; and
- (e) any other matter which is to be, or may be, prescribed.

CHAPTER XIII

OFFENCES, PENALTIES AND PROCEDURE

177. General provision for punishment of offences.

Whoever contravenes any provision of this Act or of any rule, regulation or notification made thereunder shall, if no penalty is provided for the offence be punishable for the first offence with fine which may extend to one hundred rupees, and for any second or subsequent offence with fine which may extend to three hundred rupees.

178. Penalty for travelling without pass or ticket and for dereliction of duty on the part of conductor and refusal to ply contract carriage, etc.

(1) Whoever travels in a stage carriage without having a proper pass or ticket with him or being in or having alighted from a stage carriage fails or refuses to present for examination or to deliver up his pass or ticket immediately on a requisition being made therefor, shall be punishable with fine which may extend to five hundred rupees.

Explanation.-In this section, "pass" and "ticket" have the meanings respectively assigned to them in section 124.

(2) If the conductor of a stage carriage, or the driver of a stage carriage performing the functions of a conductor in such stage carriage, whose duty is-

(a) to supply a ticket to a person travelling in a stage carriage on payment of fare by such person, either wilfully or negligently,-

(i) fails or refuses to accept the fare when tendered, or

(ii) fails or refuses to supply a ticket, or

(iii) supplies an invalid ticket, or

(iv) supplies a ticket of a lesser value, or

(b) to check any pass or ticket, either wilfully or negligently fails or refuses to do so,

he shall be punishable with fine which may extend to five hundred rupees.

(3) If the holder of a permit or the driver of a contract carriage refuses, in contravention of the provisions of this Act or rules made thereunder, to ply the contract carriage or to carry the passengers, he shall,-

(a) in the case of two-wheeled or three-wheeled motor vehicles, be punishable with fine which may extend to fifty rupees; and

(b) in any other case, be punishable with fine which may extend to two hundred rupees.

179. Disobedience of orders, obstruction and refusal of information.

(1) Whoever wilfully disobeys any direction lawfully given by any person or authority empowered under this Act to give such direction, or obstructs any person or authority in the discharge of any functions which such person or authority is required or empowered under this Act to discharge, shall, if no other penalty is provided for the offence be punishable with fine which may extend to five hundred rupees.

(2) Whoever, being required by or under this Act to supply any information, wilfully withholds such information or gives information which he knows to be false or which he does not believe to be true, shall, if no other penalty is provided for the offence, be punishable with imprisonment for a term which may extend to one month, or with fine which may extend to five hundred rupees, or with both.

180. Allowing unauthorised persons to drive vehicles.

Whoever, being the owner or person in charge of a motor vehicle, causes or permits, any other person who does not satisfy the provisions of section 3 or section 4 to drive the vehicle shall be punishable with imprisonment for a term which may extend to three months, or with fine which may extend to one thousand rupees, or with both.

181. Driving vehicles in contravention of section 3 or section 4.

Whoever drives a motor vehicle in contravention of section 3 or section 4 shall be punishable with imprisonment for a term which may extend to three months, or with fine which may extend to five hundred rupees, or with both.

182. Offences relating to licences.

(1) Whoever, being disqualified under this Act for holding or obtaining a driving licence drives a motor vehicle in a public place or in any other place, or applies for or obtains a driving licence or, not being entitled to have a driving licence issued to him free of endorsement, applies for or obtains a driving licence without disclosing the endorsement made on a driving licence previously held by him shall be punishable with imprisonment for a term which may extend to three months, or with fine which may extend to five hundred rupees or with both, and any driving licence so obtained by him shall be of no effect.

(2) Whoever, being disqualified under this Act for holding or obtaining a conductor's licence, acts as a conductor of a stage carriage in a public place or applies for or obtains a conductor's licence or, not being entitled to have a conductor's licence issued to him free of endorsement, applies for or obtains a conductor's licence without disclosing the endorsements made on a conductor's licence previously held by him, shall be punishable with imprisonment for a term which may extend to one month, or with fine which may extend to one hundred rupees, or with both, and any conductor's licence so obtained by him shall be of no effect.

¹[182A. Punishment for offences relating to construction and maintenance of vehicles.

Any person who contravenes the provisions of sub-section (3) of section 109, shall be punishable with a fine of one thousand rupees for the first offence and with a fine of five thousand rupees for any subsequent offences.]

183. Driving at excessive speed, etc.

(1) Whoever drives a motor vehicle in contravention of the speed limits referred to in section 112 shall be punishable with fine which may extend to four hundred rupees, or, if having been previously convicted of an offence under this sub-section is again convicted of an offence under this sub-section, with fine which may extend to one thousand rupees.

(2) Whoever causes any person who is employed by him or is subject to his control in driving to drive a motor vehicle in contravention of the speed limits referred to in section 112 shall be punishable with fine which may extend to three hundred rupees, or, if having been previously convicted of an offence under this sub-section, is again convicted of an offence under this sub-section, with fine which may extend to five hundred rupees.

(3) No person shall be convicted of an offence punishable under sub-section (1) solely on the evidence of one witness to the effect that in the opinion of the witness such person was driving at a speed which was unlawful, unless that opinion is shown to be based on an estimate obtained by the use of some mechanical device.

(4) The publication of a time table under which or the giving of any direction that any journey or part of a journey is to be completed within a specified time shall, if in the opinion of the Court it is not practicable in the circumstances of the case for that journey or part of a journey to be completed in the specified time without contravening the speed limits referred to in section 112 be prima fade evidence that the person who published the time table or gave the direction has committed an offence punishable under sub-section (2).

184. Driving dangerously.

Whoever drives a motor vehicle at a speed or in a manner which is dangerous to the public, having regard to all the circumstances of the case including the nature, condition and use of the place where the vehicle is driven and the amount of traffic which actually is at the time or which might reasonably be expected to be in the place, shall be punishable for the first offence with imprisonment for a term which may extend to six months or with fine which may extend to one thousand rupees, and for any second or subsequent offence if committed within three years of the commission of a previous similar offence with imprisonment for a term which may extend to two years, or with fine which may extend to two thousand rupees, or with both.

185. Driving by a drunken person or by a person under the influence of drugs.

Whoever, while driving, or attempting to drive, a motor vehicle,-

²[(a) has, in his blood, alcohol exceeding 30 mg. per 100 ml. of blood detected in a test by a breath analyser, or]

1. Ins. by Act 54 of 1994, sec. 54 (w.e.f. 14-11-1994).

2. Subs. by Act 54 of 1994, sec. 55, for clause (a) (w.e.f. 14-11-1994).

- (b) is under this influence of a drug to such an extent as to be incapable of exercising proper control over the vehicle,

shall be punishable for the first offence with imprisonment for a term which may extend to six months, or with fine which may extend to two thousand rupees, or with both; and for a second or subsequent offence, if committed within three years of the commission of the previous similar offence, with imprisonment for a term which may extend to two years, or with fine which may extend to three thousand rupees, or with both.

Explanation.-For the purposes of this section, the drug or drugs specified by the Central Government in this behalf, by notification in the Official Gazette, shall be deemed to render a person incapable of exercising proper control over a motor vehicle.

186. Driving when mentally or physically unfit to drive.

Whoever drives a motor vehicle in any public place when he is to his knowledge suffering from any disease or disability calculated to cause his driving of the vehicle to be a source of danger to the public, shall be punishable for the first offence with fine which may extend to two hundred rupees and for a second or subsequent offence with fine which may extend to five hundred rupees.

187. Punishment for offences relating to accident.

Whoever fails to comply with the provisions of clause (c) of sub-section (1) of section 132 or of section 133 or section 134 shall be punishable with imprisonment for a term which may extend to three months, or with fine which may extend to five hundred rupees, or with both or, if having been previously convicted of an offence under this section, he is again convicted of an offence under this section, with imprisonment for a term which may extend to six months, or with fine which may extend to one thousand rupees, or with both.

188. Punishment for abetment of certain offences.

Whoever abets the commission of an offence under section 184 or section 185 or section 186 shall be punishable with the punishment provided for the offence.

189. Racing and trials of speed.

Whoever without the written consent of the State Government permits or takes part in a race or trial of speed of any kind between motor vehicles in any public place shall be punishable with imprisonment for a term which may extend to one month, or with a fine which may extend to five hundred rupees, or with both.

190. Using vehicle in unsafe condition.

(1) Any person who drives or causes or allows to be driven in any public place a motor vehicle or trailer while the vehicle or trailer has any defect, which such person knows of or could have discovered by the exercise of ordinary care and which is calculated to render the driving of the vehicle a source of danger to persons and vehicles using such place, shall be

punishable with fine which may extend to two hundred and fifty rupees or, if as a result of such defect an accident is caused causing bodily injury or damage to property, with imprisonment for a term which may extend to three months, or with fine which may extend to one thousand rupees, or with both.

(2) Any person who drives or causes or allows to be driven, in any public place a motor vehicle, which violates the standards prescribed in relation to road safety, control of noise and air-pollution,' shall be punishable for the first offence with a fine of one thousand rupees and for any second or subsequent offence with a fine of two thousand rupees.

(3) Any person who drives or causes or allows to be driven, in any public place a motor vehicle which violates the provisions of this Act or the rules made thereunder relating to the carriage of goods which are of dangerous or hazardous nature to human life, shall be punishable for the first offence which may extend to three thousand rupees, or with imprisonment for a term which may extend to one year, or with both, and for any second or subsequent offence with fine which may extend to five thousand rupees, or with imprisonment for a term which may extend to three years, or with both.

191. Sale of vehicle in or alteration of vehicle to condition contravening this Act.

Whoever being an importer of or dealer in motor vehicles, sells or delivers or offers to sell or deliver a motor vehicle or trailer in such condition that the use thereof in a public place would be in contravention of Chapter VII or any rule made thereunder or alters the motor vehicle or trailer so as to render its condition such that its use in a public place would be in contravention of Chapter VII or any rule made thereunder shall be punishable with fine which may extend to five hundred rupees:

Provided that no person shall be convicted under this section if he proves that he had reasonable cause to believe that the vehicle would not be used in a public place until it had been put into a condition in which it might lawfully be so used.

192. Using vehicle without registration.

¹[192. Using vehicle without registration.

(1) Whoever drives a motor vehicle or causes or allows a motor vehicle to be used in contravention of the provisions of section 39 shall be punishable for the first offence with a fine which may extend to five thousand rupees but shall not be less than two thousand rupees for a second or subsequent offence with imprisonment which may extend to one year or with fine which may extend to ten thousand rupees but shall not be less than five thousand rupees or with both:

Provided that the Court may, for reasons to be recorded, impose a lesser punishment.

(2) Nothing in this section shall apply to the use of a motor vehicle in an emergency for the conveyance of persons suffering from sickness or injuries or for the transport of food or materials to relieve distress or of medical supplies for a like purpose:

Provided that the person using the vehicle reports about the same to the Regional Transport Authority within seven days from the date of such use.

¹ Subs, by Act 54 of 1994, sec. 56, for section 192 (w.e.f. 14-11-1994).

(3) The Court to which an appeal lies from any conviction in respect of an offence of the nature specified in sub-section (1), may set aside or vary any order made by the Court below, notwithstanding that no appeal lies against the conviction in connection with which such order was made.

192A. Using vehicle without permit.

¹[192A. Using vehicle without permit.

(1) Whoever drives a motor vehicle or causes or allows a motor vehicle to be used in contravention of the provisions of sub-section (1) of section 66 or in contravention of any condition of a permit relating to the route on which or the area in which or the purpose for which the vehicle may be used, shall be punishable for the first offence with a fine which may extend to five thousand rupees but shall not be less than two thousand rupees and for any subsequent offence with imprisonment which may extend to one year but shall not be less than three months or with fine which may extend to ten thousand rupees but shall not be less than five thousand rupees or with both:

Provided that the court may for reasons to be recorded, impose a lesser punishment.

(2) Nothing in this section shall apply to the use of a motor vehicle in an emergency for the conveyance of persons suffering from sickness or injury or for the transport of materials for repair or for the transport of food or materials to relieve distress or of medical supplies for a like purpose:

Provided that the person using the vehicle reports about the same to the Regional Transport Authority within seven days from the date of such use.

(3) The court to which an appeal lies from any conviction in respect of an offence of the nature specified in sub-section (1), may set aside or vary any order made by the court below, notwithstanding that no appeal lies against the conviction in connection with which such order was made.]

193. Punishment of agents and canvassers without proper authority.

Whoever engages himself as an agent or canvasser in contravention of the provisions of section 93 or of any rules made thereunder shall be punishable for the first offence with fine which may extend to one thousand rupees and for any second or subsequent offence with imprisonment which may extend to six months, or with fine which may extend to two thousand rupees, or with both.

194. Driving vehicle exceeding permissible weight.

²[(1) Whoever drives a motor vehicle or causes or allows a motor vehicle to be driven in contravention of the provisions of section 113 or section 114 or section 115 shall be punishable with minimum fine of two thousand rupees and an additional amount of one thousand rupees per tonne of excess load, together with the liability to pay charges for off-loading of the excess load].

1. Subs, by Act 54 of 1994, sec. 56, for section 192 (w.e.f. 14-11-1994).

2. Subs, by Act 54 of 1994, sec. 57, for sub-section (1) (w.e.f. 14-11-1994).

(2) Any driver of a vehicle who refuses to stop and submit his vehicle to weighing after being directed to do so by an officer authorised in this behalf under section 114 or removes or causes the removal of the load or part of it prior to weighing shall be punishable with fine which may extend to three thousand rupees.

195. Imposition of minimum fine under certain circumstances.

(1) Whoever having been convicted of an offence under this Act or the rules made thereunder commits a similar offence on a second or subsequent occasion within three years of the commission of the previous offence, no Court shall, except for reasons to be recorded by it in writing, impose on him a fine of less than one-fourth of the maximum amount of the fine imposable for such offence.

(2) Nothing in sub-section (1) shall be construed as restricting the power of the Court from awarding such imprisonment as it considers necessary in the circumstances of the case not exceeding the maximum specified in this Act in respect of that offence

196. Driving uninsured vehicle.

Whoever drives a motor vehicle or causes or allows a motor vehicle to be driven in contravention of the provisions of section 146 shall be punishable with imprisonment which may extend to three months, or with fine which may extend to one thousand rupees, or with both.

197. Taking vehicle without authority.

(1) Whoever takes and drives away any motor vehicle without having either the consent of the owner thereof or other lawful authority shall be punishable with imprisonment which may extend to three months, or with fine which may extend to five hundred rupees, or with both:

Provided that no person shall be convicted under this section if the Court is satisfied that such person acted in the reasonable belief that he had lawful authority or in the reasonable belief that the owner would in the circumstances of the case have given his consent if he had been asked therefor.

(2) Whoever, unlawfully by force or threat of force or by any other form of intimidation, seizes or exercises control of a motor vehicle, shall be punishable with imprisonment which may extend to three months, or with fine which may extend to five hundred rupees, or with both.

(3) Whoever attempts to commit any of the acts referred to in sub-section (1) or sub-section (2) in relation to any motor vehicle, or abets the commission of any such act, shall also be deemed to have committed an offence under sub-section (1) or, as the case may be, sub-section (2).

198. Unauthorised interference with vehicle.

Whoever otherwise than with lawful authority or reasonable excuse enters or moves any

stationary motor vehicle or tampers with the brake or any part of the mechanism of a motor vehicle shall be punishable with fine which may extend to one hundred rupees.

199. Offences by companies.

(1) Where an offence under this Act has been committed by a company, every person who, at the time the offence was committed, was in charge of, and was responsible to, the company for the conduct of the business of the company, as well as the company, shall be deemed to be guilty of the contravention and shall be liable to be proceeded against and punished accordingly:

Provided that nothing in this sub-section shall render any such person liable to any punishment provided in this Act, if he proves that the offence was committed without his knowledge or that he exercised all due diligence to prevent the commission of such offence.

(2) Notwithstanding anything contained in sub-section (1), where an offence under this Act has been committed by a company, and it is proved that the offence was committed with the consent or connivance of, or is attributable to any neglect on the part of any director, manager, secretary or other officer of the company, such director, manager, secretary or other officer shall also be deemed to be guilty of that offence and shall be liable to be proceeded against and punished accordingly.

Explanation.-For the purposes of this section-

(a) "company", means any body corporate and includes a firm or other association of individuals; and

(b) "director", in relation to a firm, means a partner in the firm.

200. Composition of certain offences.

(1) Any offence whether committed before or after the commencement of this Act punishable under section 177, section 178, section 179, section 180, section 181, section 182, sub-section (1) or sub-section (2) of section 183, section 184, section 186,¹[section 189, sub-section (2) of section 190]; section 191, section 192, section 194, section 196, or section 198, may either before or after the institution of the prosecution, be compounded by such officers or authorities and for such amount as the State Government may, by notification in the Official Gazette, specify in this behalf.

(2) Where an offence has been compounded under sub-section (1) the offender, if in custody, shall be discharged and no further proceedings shall be taken against him in respect of such offence.

1. Subs. by Act 54 of 1994, sec. 58, for "section 189" (w.e.f. 14-11-1994).

201. Penalty for causing obstruction to free flow of traffic.

(1) Whoever keeps a disabled vehicle on any public place, in such a manner, so as to cause impediment to the free flow of traffic, shall be liable for penalty up to fifty rupees per hour, so long as it remains in that position:

Provided that the vehicle involved in accidents shall be liable for penalty only from the time of completion of inspection formalities under the law:

¹[Provided further that where the vehicle is removed by a Government agency, towing charges shall be recovered from the vehicle owner or person in-charge of such vehicle.]

²[(2) Penalties or towing charges under this section shall be recovered by such officer or authority as the State Government may, by notification in the Official Gazette, authorise.]

202. Power to arrest without warrant.

(1) A police officer in uniform may arrest without warrant any person who in his presence commits an offence punishable under section 184 or section 185 or section 197:

Provided that any person so arrested in connection with an offence punishable under section 185 shall, within two hours of his arrest, be subjected to a medical examination referred to in sections 203 and 204 by a registered medical practitioner failing which he shall be released from custody.

³[(2) A police officer in uniform may arrest without warrant any person, who has committed an offence under this Act, if such person refuses to give his name and address.]

(3) A police officer arresting without warrant the driver of a motor vehicle shall if the circumstances so require take or cause to be taken any steps he may consider proper for the temporary disposal of the vehicle.

203. Breath tests.

⁴[(1) A police officer in uniform or an officer of the Motor Vehicles Department, as may be authorised in this behalf by that Department, may require any person driving or attempting to drive a motor vehicle in a public place to provide one or more specimens of breath for breath test there or nearby, if such police officer or officer has any reasonable cause to suspect him of having committed an offence under section 185:

Provided that requirement for breath test shall be made (unless, it is made) as soon as reasonably practicable after the commission of such offence.]

1. Ins. by Act 54 of 1994, sec. 59 (w.e.f. 14-11-1994).

2. Subs. by Act 54 of 1994, sec. 59, for sub-section (2) (w.e.f. 14-11-1994)

3. Subs. by Act 54 of 1994, sec. 60, for sub-section (2) (w.e.f. 14-11-1994).

4. Subs. by Act 54 of 1994, sec. 61, for sub-section (1) (w.e.f. 14-11-1994).

(2) If a motor vehicle is involved in an accident in a public place and a police officer in uniform has any reasonable cause to suspect that the person who was driving the motor vehicle at the time of the accident had alcohol in his blood or that he was driving under the influence of a drug referred to in section 185 he may require the person so driving the motor vehicle, to provide a specimen of his breath for a breath test-

(a) in the case of a person who is at a hospital as an indoor patient, at the hospital,

(b) in the case of any other person, either at or near the place where the requirement is made, or, if the police officer thinks fit, at a police station specified by the police officer:

Provided that a person shall not be required to provide such a specimen while at a hospital as an indoor patient if the registered medical practitioner in immediate charge of his case is not first notified of the proposal to make the requirement or objects to the provision of a specimen on the ground that its provision or the requirement to provide it would be prejudicial to the proper care or treatment of the patient.

(3) If it appears to a police officer in uniform, in consequence of a breath test carried out by him on any person under sub-section (1) or sub-section

(2) that the device by means of which the test has been carried out indicates the presence of alcohol in the person's blood, the police officer may arrest that person without warrant except while that person is at a hospital as an indoor patient.

(4) If a person, required by a police officer under sub-section (1) or subsection (2) to provide a specimen of breath for a breath test, refuses or fails to do so and the police officer has reasonable cause to suspect him of having alcohol in his blood, the police officer may arrest him without warrant except while he is at a hospital as an indoor patient.

(5) A person arrested under this section shall while at a police station, be given an opportunity to provide a specimen of breath for a breath test there.

(6) The results of a breath test made in pursuance of the provisions of this section shall be admissible in evidence.

Explanation.-For the purposes of this section "breath test", means a test for the purpose of obtaining an indication of the presence of alcohol in a person's blood carried out on one or more specimens of breath provided by that person, by means of a device of a type approved by the Central Government by notification in the Official Gazette, for the purpose of such a test.

204. Laboratory test.

(1) A person who has been arrested under section 203 may, while at a police station be required by a police officer to provide to such registered medical practitioner as may be produced by such police officer, a specimen of his blood for a laboratory test if,-

(a) it appears to the police officer that the device, by means of which breath test was taken in relation to such person, indicates the presence of alcohol in the blood of such person, or

- (b) such person, when given the opportunity to submit to a breath test, has refused, omitted or failed to do so:

Provided that where the person required to provide such specimen is a female and the registered medical practitioner produced by such police officer is a male medical practitioner, the specimen shall be taken only in the presence of a female, whether a medical practitioner or not.

(2) A person while at a hospital as an indoor patient may be required by a police officer to provide at the hospital a specimen of his blood for a laboratory test-

- (a) if it appears to the police officer that the device by means of which test is carried out in relation to the breath of such person indicates the presence of alcohol in the blood of such person, or
- (b) if the person having been required, whether at the hospital or elsewhere, to provide a specimen of breath for a breath test, has refused, omitted or failed to do so and a police officer has reasonable cause to suspect him of having alcohol in his blood:

Provided that a person shall not be required to provide a specimen of his blood for a laboratory test under this sub-section if the registered medical practitioner in immediate charge of his case is not first notified of the proposal to make the requirement or objects to the provision of such specimen on the ground that its provision or the requirement to provide it would be prejudicial to the proper care or treatment of the patient.

(3) The results of a laboratory test made in pursuance of this section shall be admissible in evidence.

Explanation.-For the purposes of this section, "laboratory test" means the analysis of a specimen of blood made at a laboratory established, maintained or recognised by the Central Government or a State Government.

205. Presumption of unfitness to drive.

In any proceeding for an offence punishable under section 185 if it is proved that the accused when requested by a police officer at any time so to do, had refused, omitted or failed to consent to the taking of or providing a specimen of his breath for a breath test or a specimen of his blood for a laboratory test, his refusal, omission or failure may, unless reasonable cause therefor is shown, be presumed to be a circumstance supporting any evidence given on behalf of the prosecution, or rebutting any evidence given on behalf of the defence, with respect to his condition at that time.

206. Power of police officer to impound document.

(1) Any police officer or other person authorised in this behalf by the State Government may, if he has reason to believe that any identification mark carried on a motor vehicle or any licence, permit, certificate of registration, certificate of insurance or other document produced to him by the driver or person in charge of a motor vehicle is a false document within the meaning of section 464 of the Indian Penal Code, 1860 (45 of 1860) seize the mark or

document and call upon the driver or owner of the vehicle to account for his possession of or the presence in the vehicle of such mark or document.

(2) Any police officer or other person authorised in this behalf by the State Government may, if he has reason to believe that the driver of a motor vehicle who is charged with any offence under this Act may abscond or otherwise avoid the service of a summons, seize any licence held by such driver and forward it into the Court taking cognizance of the offence and the said Court shall on the first appearance of such driver before it, return the licence to him in exchange for the temporary acknowledgment given under sub-section (3).

(3) A police officer or other person seizing a licence under sub-section (2) shall give to the person surrendering the licence a temporary acknowledgment therefor and such acknowledgment shall authorise the holder to drive until the licence has been returned to him or until such date as may be specified by the police officer or other person in the acknowledgment whichever is earlier:

Provided that if any Magistrate, police officer or other person authorised by the State Government in this behalf is, on an application made to him, satisfied that the licence cannot be, or has not been, returned to the holder thereof before the date specified in the acknowledgment for any reason for which the holder is not responsible, the Magistrate, police officer or other person, as the case may be, may extend the period of authorization to drive to such date as may be specified in the acknowledgment.

207. Power to detain vehicles used without certificate of registration permit, etc.

(1) Any police officer or other person authorised in this behalf by the State Government may, if he has reason to believe that a motor vehicle has been or is being used in contravention of the provisions of section 3 or section 4 or section 39 or without the permit required by sub-section (1) of section 66 or in contravention or any condition of such permit relating to the route on which or the area in which or the purpose for which the vehicle may be used, seize and detain the vehicle, in the prescribed manner and for this purpose take or cause to be taken any steps he may consider proper for the temporary safe custody of the vehicle:

Provided that where any such officer or person has reason to believe that a motor vehicle has been or is being used in contravention of section 3 or section 4 or without the permit required by sub-section (1) of section 66 he may, instead of seizing the vehicle, seize the certificate of registration of the vehicle and shall issue an acknowledgment in respect thereof.

(2) Where a motor vehicle has been seized and detained under sub-section (1), the owner or person incharge of the motor vehicle may apply to the transport authority or any officer authorised in this behalf by the State Government together with the relevant documents for the release of the vehicle and such authority or officer may, after verification of such documents, by order release the vehicle subject to such conditions as the authority or officer may deem fit to impose.

208. Summary disposal of cases.

(1) The Court taking cognizance of any offence (other than an offence which the Central Government may by rules specify in this behalf) under this Act,-

- (i) may, if the offence is an offence punishable with imprisonment under this Act; and
- (ii) shall, in any other case,

state upon the summons to be served on the accused person that he-

- (a) may appear by pleader or in person; or
- (b) may, by a specified date prior to the hearing of the charge, plead guilty to the charge and remit to the Court, by money order, such sum (not exceeding the maximum fine that may be imposed for the offence) as the Court may specify, and the plea of guilt indicated in the money order coupon itself:

Provided that the Court shall, in the case of any of the offences referred to in sub-section (2), state upon the summons that the accused person, if he pleads guilty, shall so plead in the manner specified in clause (b) and shall forward his driving licence to the Court with his letter containing such plea.

(2) Where the offence dealt with in accordance with sub-section (1) is an offence specified by the Central Government by rules for the purposes of this sub-section, the Court shall, if the accused person pleads guilty to the charge and forward his driving licence to the Court with the letter containing his plea, make an endorsement of such conviction on his driving licence.

(3) Where an accused person pleads guilty and remits the sum specified and has complied with the provisions of sub-section (1), or as the case may be, subsections (1) and (2), no further proceedings in respect of the offence shall be taken against him nor shall he be liable, notwithstanding anything to the contrary contained in this Act, to be disqualified for holding or obtaining a licence by reason of his having pleaded guilty.

209. Restriction on conviction.

No person prosecuted for an offence punishable under section 183 or section 184 shall be convicted unless-

- (a) he was warned at the time the offence was committed that the question of prosecuting him would be taken into consideration, or
- (b) within fourteen days from the commission of the offence, a notice specifying the nature of the offence and the time and place where it is alleged to have been committed was served on or sent by registered post to him or the person registered as the owner of the vehicle at the time of the commission of the offence, or
- (c) within twenty-eight days of the commission of the offence, a summons for the offence was served on him:

Provided that nothing, in this section shall apply where the Court is satisfied that-

- (a) the failure to serve the notice or summons referred to in this subsection was due to the fact that neither the name and address of the accused nor the name and

address of the registered owner of the vehicle could with reasonable diligence have been ascertained in time, or

- (b) such failure was brought about by the conduct of the accused.

210. Courts to send intimation about conviction.

Every Court by which any person holding a driving licence is convicted of an offence under this Act or of an offence in the commission of which a motor vehicle was used, shall send intimation to-

- (a) the licensing authority which issued the driving licence, and
- (b) the licensing authority by whom the licence was last renewed,

and every such intimation shall state the name and address of the holder of the licence, the licence number, the date of issue and renewal of the same, the nature of the offence, the punishment awarded for the same and such other particulars as may be prescribed.

CHAPTER XIV

MISCELLANEOUS

211. Power to levy fee.

Any rule which the Central Government or the State Government is empowered to make under this Act may, notwithstanding the absence of any express provision to that effect, provide for the levy of such fees in respect of applications, amendment of documents, issue of certificates, licences, permits, tests, endorsements, badges, plates, countersignatures, authorisation, supply of statistics or copies of documents or orders and for any other purpose or matter involving the rendering of any service by the officers or authorities under this Act or any rule made thereunder as may be considered necessary:

Provided that the Government may, if it considers necessary so to do, in the public interest by general or special order, exempt any class of persons from the payment of any such fee either in part or in full.

212. Publication, commencement and laying of rules and notifications.

- (1) The power to make rules under this Act is subject to the condition of the rules being made after previous publication.
- (2) All rules made under this Act shall be published in the Official Gazette, and shall unless some later date is appointed, come into force on the date of such publication.
- (3) Every rule made by any State Government shall be laid, as soon as may be after it is made before the State Legislature.
- (4) Every rule made by the Central Government under this Act, every scheme made by the Central Government under sub-section (1) of section 75 and sub-section (1) of section 163 and every notification issued by the Central Government under sub-section (4) of section 41, sub-section (1) of section 58, subsection (1) of section 59, the proviso to sub-section (1) of section 112, ¹[sub-section (4) of section 163A] and sub-section (4) of section 213 shall be laid, as soon as may be after it is made, before each House of Parliament while it is in session for a total period of thirty days which may be comprised in one session or in two or more successive sessions, and if, before the expiry of the session immediately following the session or the successive sessions aforesaid, both Houses agree in making any modification in the rule, scheme or notification or both Houses agree that the rule or scheme should not be made or the notification should not be issued, the rule, scheme or notification shall thereafter have effect only in such modified form or be of no effect, as the case may be; so, however, that any such modification or annulment shall be without prejudice to the validity of anything previously done under that rule, scheme or notification.

1. Ins. by Act 54 of 1994, sec. 62 (w.e.f. 14-11-1994).

213. Appointment of motor vehicles officers.

(1) The State Government may, for the purpose of carrying into effect the provisions of the Act, establish a Motor Vehicles Department and appoint as officers thereof such persons as it thinks fit.

(2) Every such officer shall be deemed to be a public servant within the meaning of the Indian Penal Code, 1860 (45 of 1860).

(3) The State Government may make rules to regulate the discharge by officers of the Motor Vehicles Department of their functions and in particular and without prejudice to the generality of the foregoing power to prescribe the uniform to be worn by them, the authorities to which they shall be subordinate, the duties to be performed by them, the powers (including the powers exercisable by police officers under this Act) to be exercised by them, and the conditions governing the exercise of such powers.

(4) The Central Government may, having regard to the objects of the Act, by notification in the Official Gazette prescribe the minimum qualifications which the said officers or any class thereof shall possess for being appointed as such.

(5) In addition to the powers that may be conferred on any officer of the Motor Vehicle Department under sub-section (3), such officer as may be empowered by the State Government in this behalf shall also have the power to,-

- (a) make such examination and inquiry as he thinks fit in order to ascertain whether the provisions of this Act and the rules made thereunder are being observed;
- (b) with such assistance, if any, as he thinks fit, enter, inspect and search any premises which is in the occupation of a person who, he has reason to believe, has committed an offence under this Act or in which a motor vehicle in respect of which such offence has been committed is kept:

Provided that,-

- (i) any such search without a warrant shall be made only by an officer of the rank of a gazetted officer;
- (ii) where the offence is punishable with fine only the search shall not be made after sunset and before sunrise;
- (iii) where the search is made without a warrant, the gazetted officer concerned shall record in writing the grounds for not obtaining a warrant and report to his immediate superior that such search has been made;
- (c) examine any person and require the production of any register or other document maintained in pursuance of this Act, and take on the spot or otherwise statements of any person which he may consider necessary for carrying out the purposes of this Act;

- (d) seize or take copies of any registers or documents or portions thereof as he may consider relevant in respect of an offence under this Act which he has reason to believe has been committed;
- (e) launch prosecutions in respect of any offence under this Act and to take a bond for ensuring the attendance of the offender before any Court;
- (f) exercise such other powers as may be prescribed;

Provided that no person shall be compelled under this sub-section to answer any question or make any statement tending to incriminate himself.

(6) The provisions of the Code of Criminal Procedure, 1973 (2 of 1974) shall, so far as may be apply to any search or seizure under this section as they apply to any search or seizure under the authority of any warrant issued under section 94 of the Code.

214. Effect of appeal and revision on orders passed by original authority.

(1) When an appeal has been preferred or an application for revision has been made against any order passed by an original authority under this Act, the appeal or the application for revision shall not operate as a stay of the order passed by the original authority and such order shall remain in force pending the disposal of the appeal or the application for revision, as the case may be, unless the prescribed appellate authority or revisional authority otherwise directs.

(2) Notwithstanding anything contained in sub-section (1), if an application made by a person for the renewal of permit has been rejected by the original authority and such person has preferred an appeal or made an application for revision under this Act against such rejection, the appellate authority or, as the case may be, the revisional authority may by order direct that the permit shall, notwithstanding the expiration of the term specified therein, continue to be valid until the appeal or application for revision is disposed of.

(3) No order made by a competent authority under this Act shall be reversed or altered on appeal or revision on account of any error, omission or irregularity in the proceedings, unless it appears to the prescribed appellate authority or revisional authority, as the case may be, that such error, omission or irregularity has, in fact, occasioned a failure of justice.

215. Road Safety Councils and Committees.

(1) The Central Government may, by notification in the Official Gazette, constitute for the country a National Road Safety Council consisting of a Chairman and such other members as that Government considers necessary and on such terms and conditions as that Government may determine.

(2) A State Government may, by notification in the Official Gazette, constitute for the State a State Road Safety Council consisting of a Chairman and such other members as that Government considers necessary and on such terms and conditions as that Government may determine.

(3) A State Government may, by notification in the Official Gazette, constitute District Road Safety Committee for each district in the State consisting of a Chairman and such other

members as that Government considers necessary and on such terms and conditions as that Government may determine.

(4) The Councils and Committees referred to in this section shall discharge such functions relating to the road safety programmes as the Central Government or the State Government, as the case may be, may, having regard to the objects of the Act, specify.

216. Power to remove difficulties.

(1) If any difficulty arises in, giving effect to the provisions of this Act, the Central Government may, by order published in the Official Gazette, make such provisions, not inconsistent with the provisions of this Act as appear to it to be necessary or expedient for removing the difficulty:

Provided that no such order shall be made after the expiry of a period of three years from the date of commencement of this Act.

(2) Every order made under this section shall, as soon as may be after it is made, be laid before each House of Parliament

217. Repeal and savings.

(1) The Motor Vehicles Act, 1939 (4 of 1939) and any law corresponding to that Act in force in any State immediately before the commencement of this Act in that State (hereafter in this section referred to as the repealed enactments) are hereby repealed.

(2) Notwithstanding the repeal by sub-section (1) of the repealed enactments,-

- (a) any notification, rule, regulation, order or notice issued, or any appointment or declaration made, or exemption granted or any confiscation made, or any penalty or fine imposed, any forfeiture, cancellation or any other thing done or any other action taken under the repealed enactments, and in force immediately before such commencement shall, so far as it is not inconsistent with the provisions of the Act, be deemed to have been issued, made, granted, done or taken under the corresponding provision of this Act;
- (b) any certificate of fitness or registration or licence or permit issued or granted under the repealed enactments shall continue to have effect after such commencement under the same conditions and for the same period as if this Act had not been passed;
- (c) any document referring to any of the repealed enactments or the provisions thereof, shall be construed as referring to this Act or to the corresponding provisions of this Act;
- (d) the assignment of distinguishing marks by the registering authority and the manner of display on motor vehicles in accordance with the provision of the repealed enactments shall, after the commencement of this Act, continue to remain in force until a notification under subsection (6) of section 41 of this Act is issued;

- (e) any scheme made under section 68C of the Motor Vehicles Act, 1939 (4 of 1939) or under the corresponding law, if any, in force in any State and pending immediately before the commencement of this Act shall be disposed of in accordance with the provisions of section 100 of this Act;
 - (f) the permits issued under sub-section (1A) of section 68F of the Motor Vehicles Act, 1939 (4 of 1939) or under the corresponding provision, if any, in force in any State immediately before the commencement of this Act shall continue to remain in force until the approved scheme under Chapter VI of this Act is published.
- (3) Any penalty payable under any of the repealed enactments may be recovered in the manner provided by or under this Act, but without prejudice to any action already taken for the recovery of such penalty under the repealed enactments.
- (4) The mention of particular matters in this section shall not be held to prejudice or affect the general application of section 6 of the General Clauses Act, 1897 (10 of 1897) with regard to the effect of repeals.

217A. Renewal of permits, driving licences and registration granted under the Motor Vehicles Act, 1939.

¹[217A. Renewal of permits, driving licences and registration granted under the Motor Vehicles Act, 1939.

Notwithstanding the repeal by subsection (1) of section 217 of the enactments referred to in that sub-section, any certificate of fitness or registration or licence or permit issued or granted under the said enactments may be renewed under this Act.]

1. Ins. by Act 27 of 2000, sec. 5 (w.e.f. 11-8-2000).

THE FIRST SCHEDULE

MANDATORY SIGNS OF THE FIRST SCHEDULE OF THE MOTOR VEHICLES ACT, 1988

PART A

No.M. 1.-Stop
 Normal Size 90c.m.
 Small Size 60c.m.

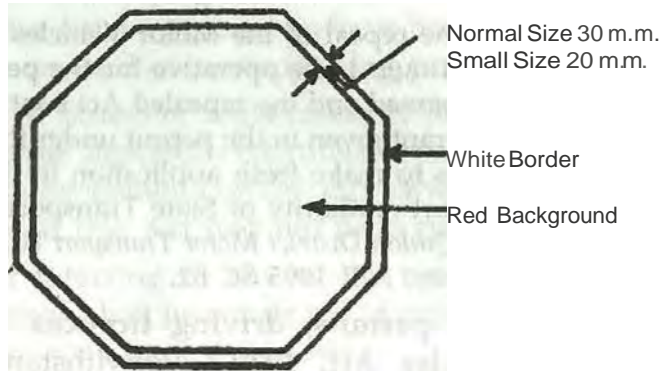

Note: Till the road users are familiar with this sign a definition plate may be attached with the sign carrying the word 'Stop' in English and other languages as necessary.

No. M.2 -Give Way
 Normal Sjeze90c.,m.
 Small Size 60 c.m.

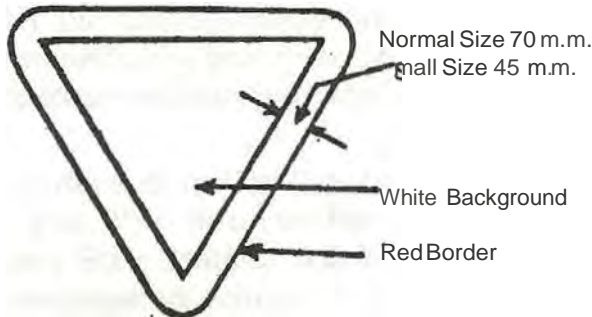

Note. Till the road users are familiar with this sign, a definition plate may be used with the sign, carrying the message 'give away' in English and other languages as necessary.

No. M 3-Straight Prohibited or No Entry

Normal Size 60c.m.
 Small Sizer c.m.

Normal Size 65 m.m
 Small Size 45 m.m.

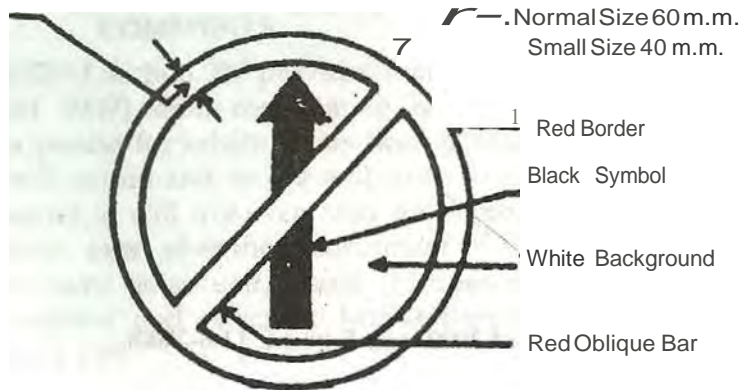

No. M 4A — One way sign—Vehicles Prohibited in one Direction

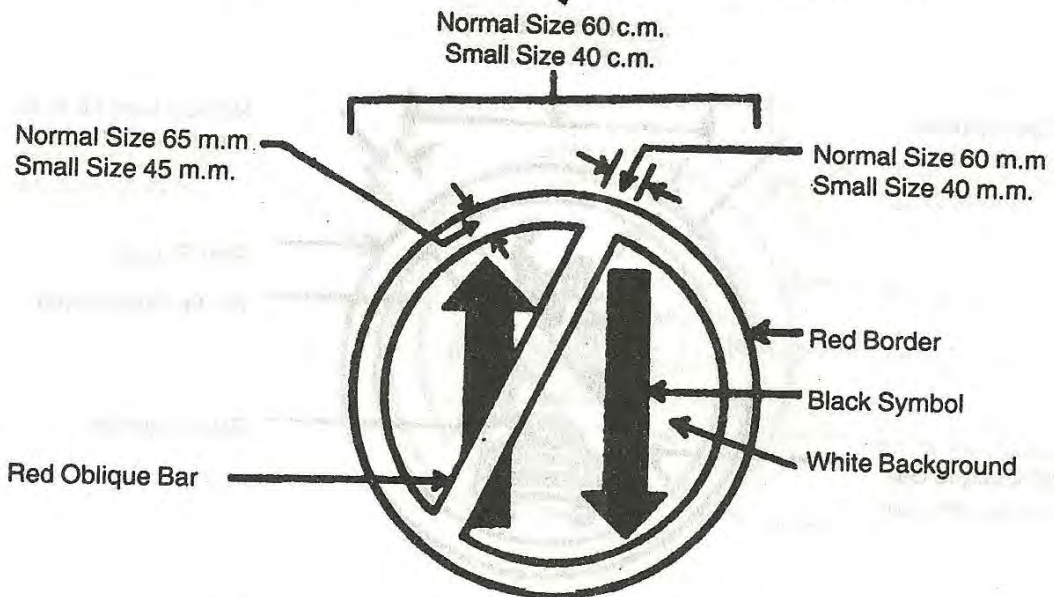

No. M 4B — One way sign—Vehicles Prohibited in one Direction

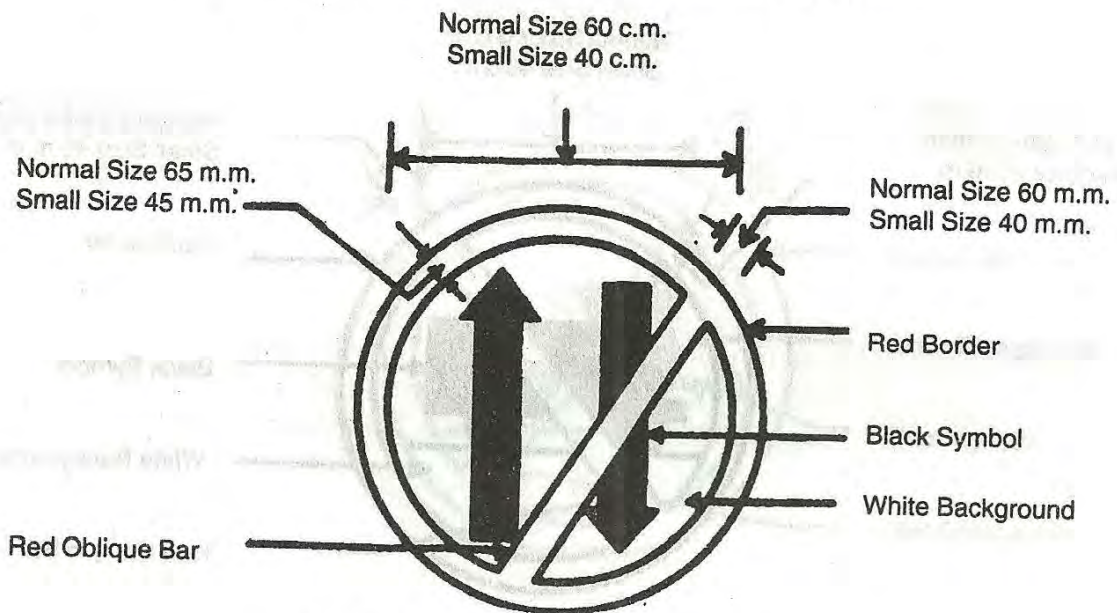

No. M 5 — Vehicles Prohibited in both Directions

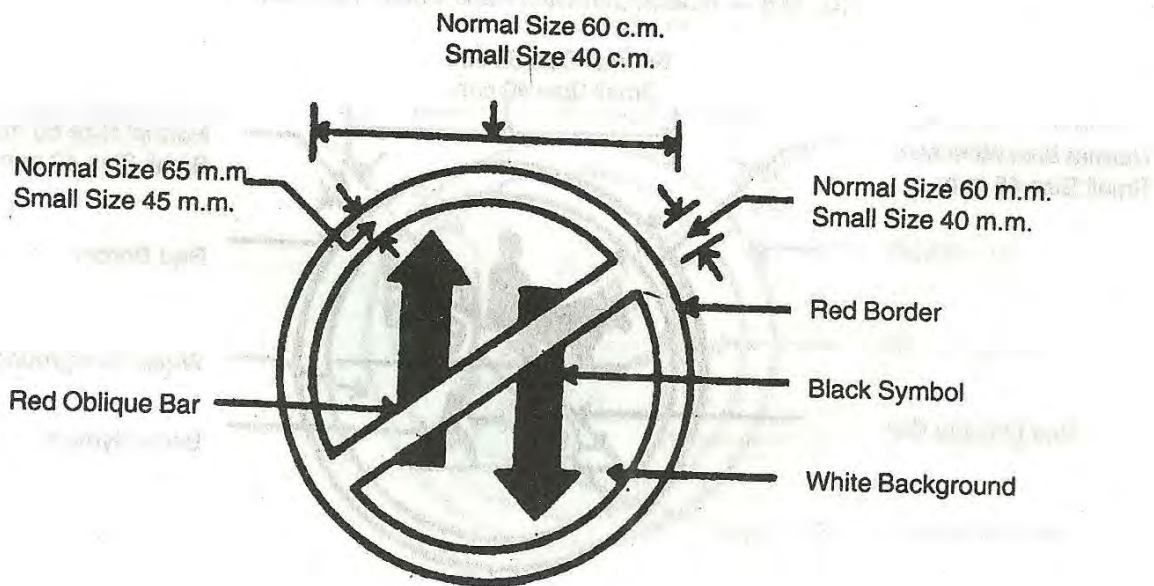

No. M 6 — All Motor Vehicles Prohibited

Normal Size 60 m.m.
Small Size 40 m.m.

Normal Size 65 m.m.
Small Size 45 m.m.

Normal Size 60 m.m.
Small Size 40 m.m.



No. M 7 — Trucks Prohibited

Normal Size 60 c.m.
Small Size 40 c.m.

Normal Size 65 m.m.
Small Size 45 m.m.

Normal Size 60 m.m.
Small Size 40 m.m.

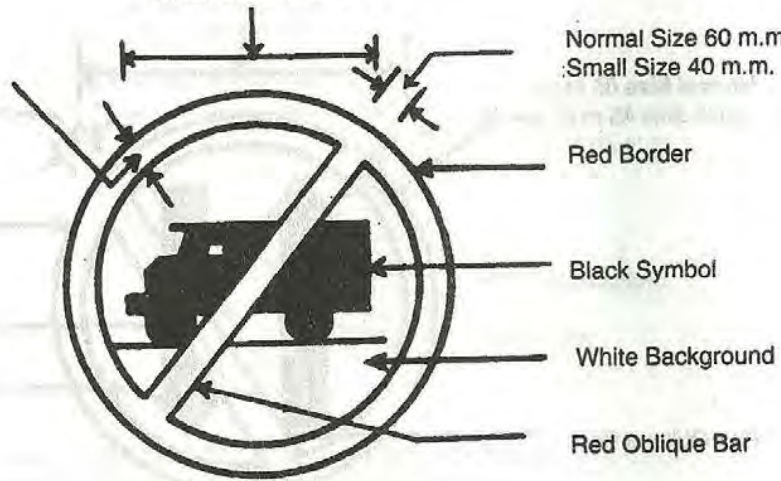

No. M 8 — Bullock Carts and Hand Carts Prohibited

Normal Size 60 c.m.
Small Size 40 c.m.

Normal Size 65 m.m.
Small Size 45 m.m.

Normal Size 60 m.m.
Small Size 40 m.m.

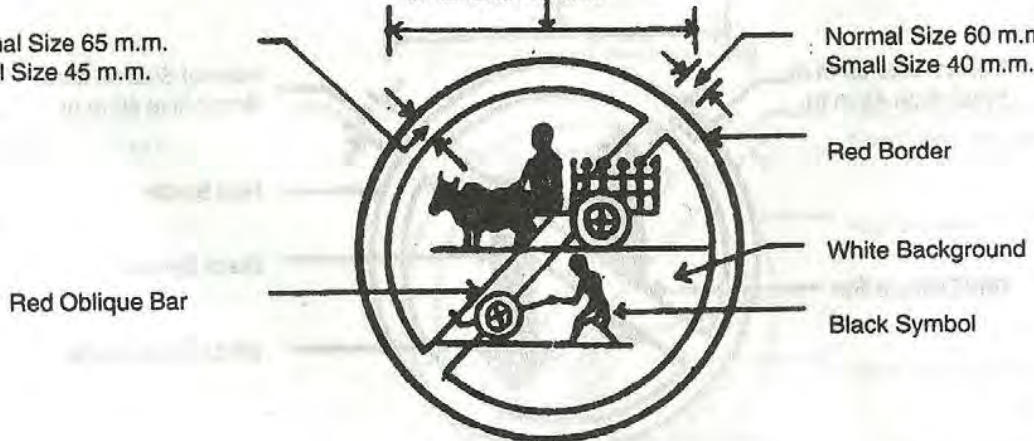

No. M 9 — Bullock Carts Prohibited

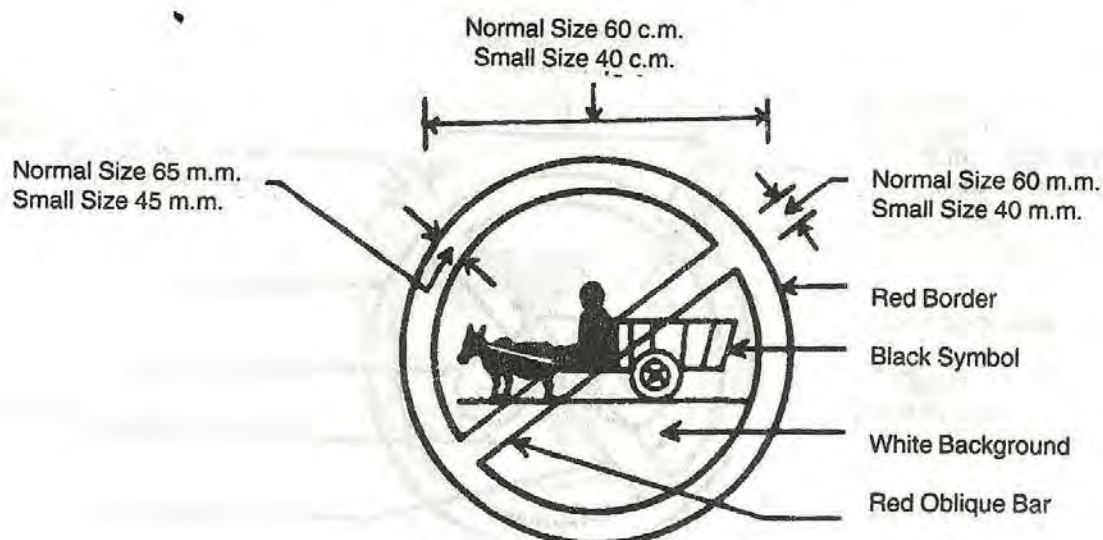

No. M 10 — Tongas Prohibited

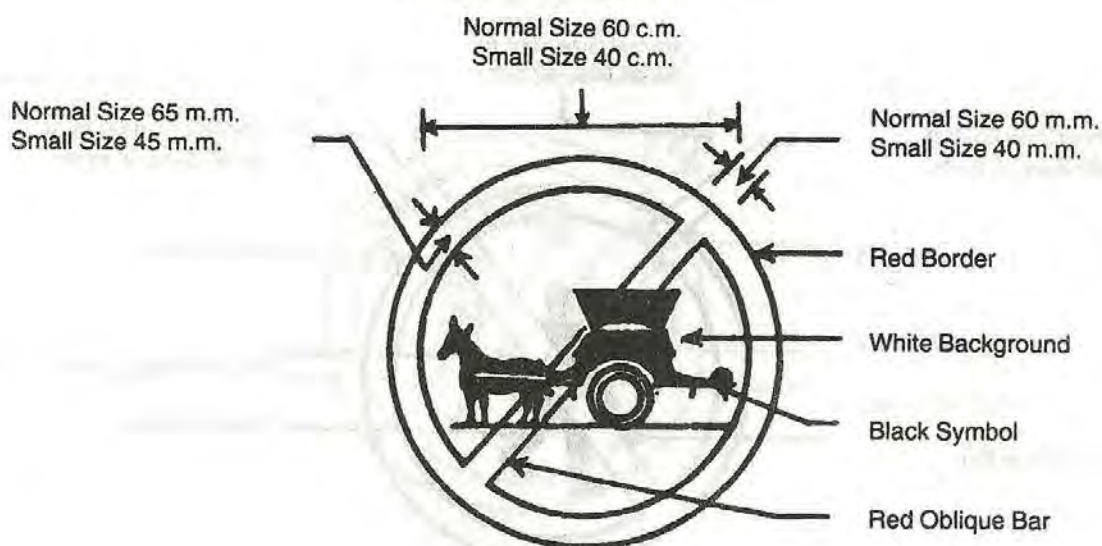

No. M 11 — Hand Carts Prohibited

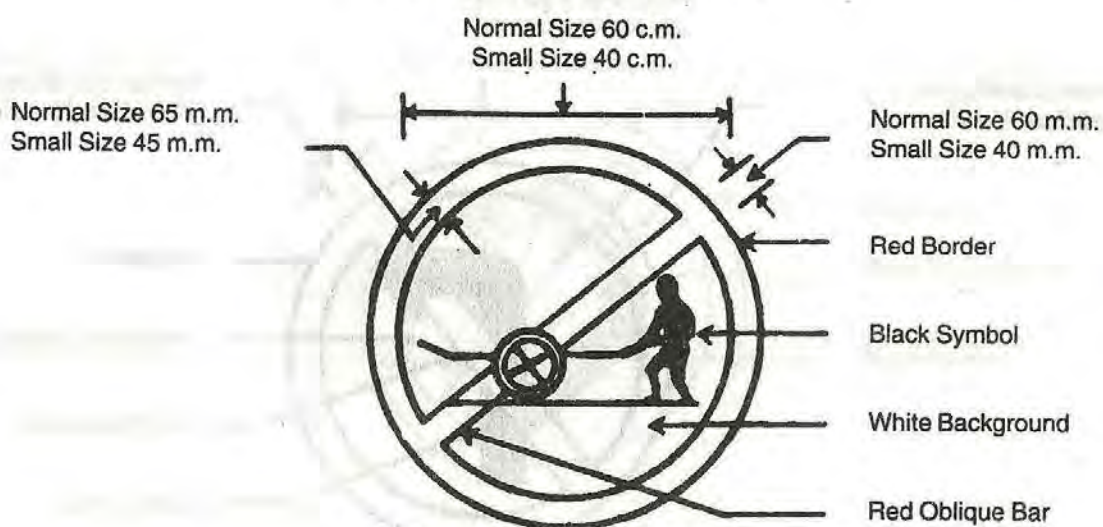

No. M 12 — Cycle Prohibited

Normal Size 60 c.m.
Small Size 40 c.m.

Normal Size 65 m.m.
Small Size 45 m.m.

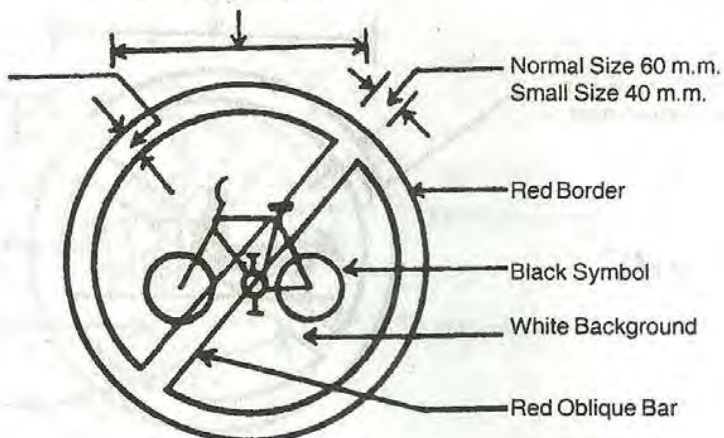

No. M 13 — Pedestrians Prohibited

Normal Size 60 c.m.
Small Size 40 c.m.

Normal Size 65 m.m.
Small Size 45 m.m.

Red Oblique Bar

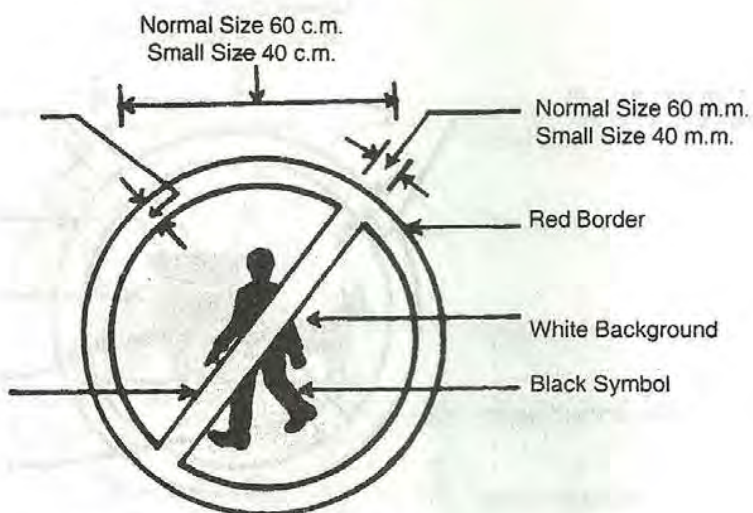

No. M 14 — Right Turn Prohibited

Normal Size 60 c.m.
Small Size 40 c.m.

Normal Size 65 m.m.
Small Size 45 m.m.

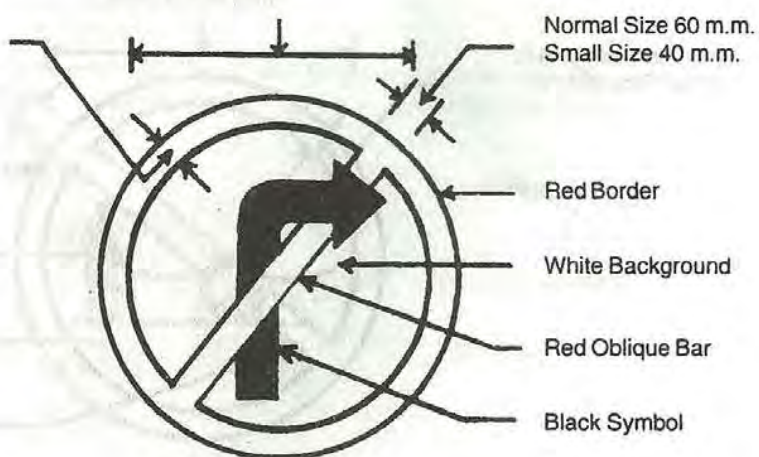

No. M 15 — Left Turn Prohibited

Normal Size 60 c.m.
Small Size 40 c.m.

Normal Size 65 m.m.
Small Size 45 m.m.

Normal Size 60 m.m.
Small Size 40 m.m.

Red Oblique Bar

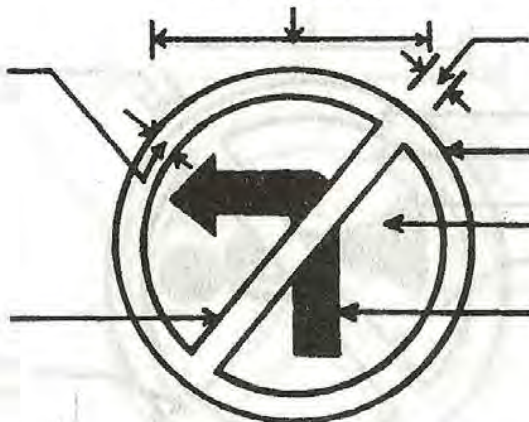

Red Border

White Background

Black Symbol

No. M 16 — U.Turn Prohibited

Normal Size 60 c.m.
Small Size 40 c.m.

Normal Size 65 m.m.
Small Size 45 m.m.

Normal Size 60 m.m.
Small Size 40 m.m.

Red Oblique Bar

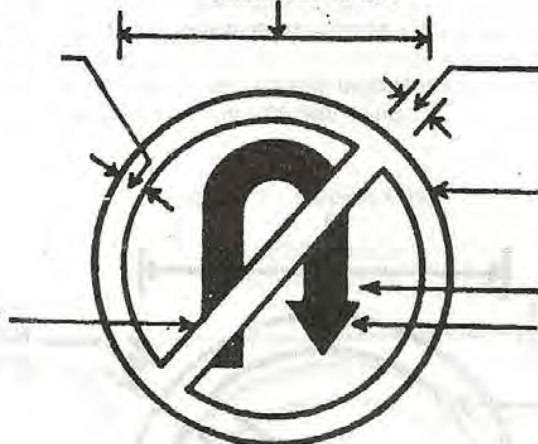

Red Border

White Background

Black Symbol

No. M 17 — Overtaking Prohibited

Normal Size 60 c.m.
Small Size 40 c.m.

Normal Size 65 m.m.
Small Size 45 m.m.

Normal Size 60 m.m.
Small Size 40 m.m.

Red Oblique Bar

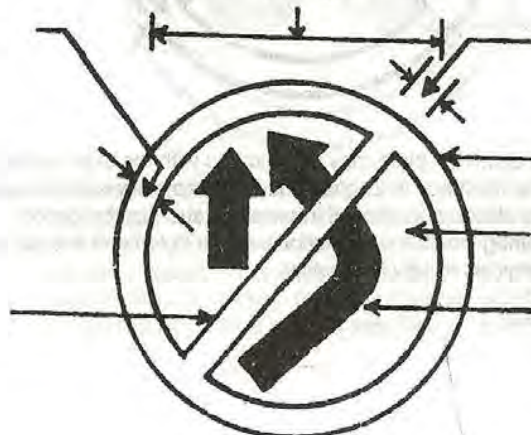

Red Border

White Background

Black Symbol

No. M 18 — Horns Prohibited

Normal Size 60 c.m.
Small Size 40 c.m.

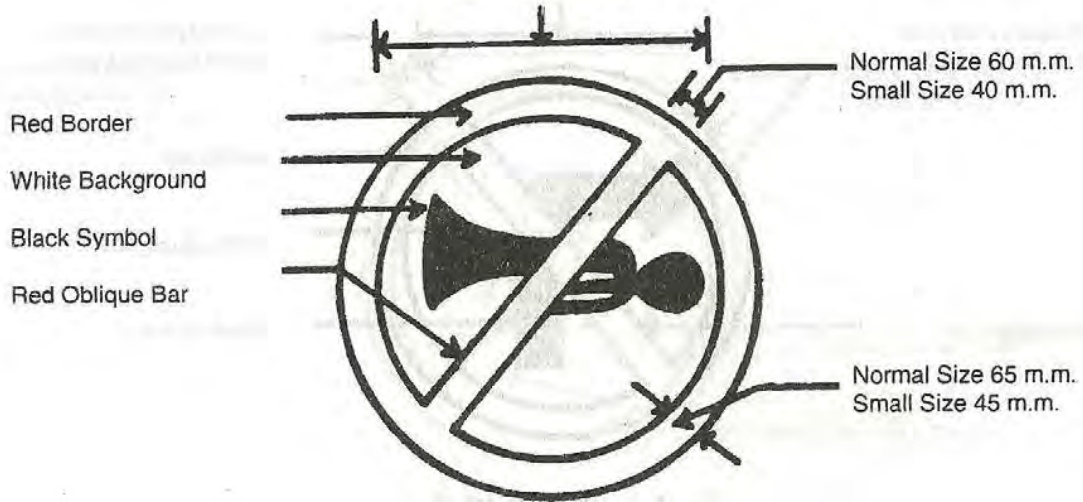

No. M 19 — No Parking

Normal Size 60 c.m.
Small Size 40 c.m.

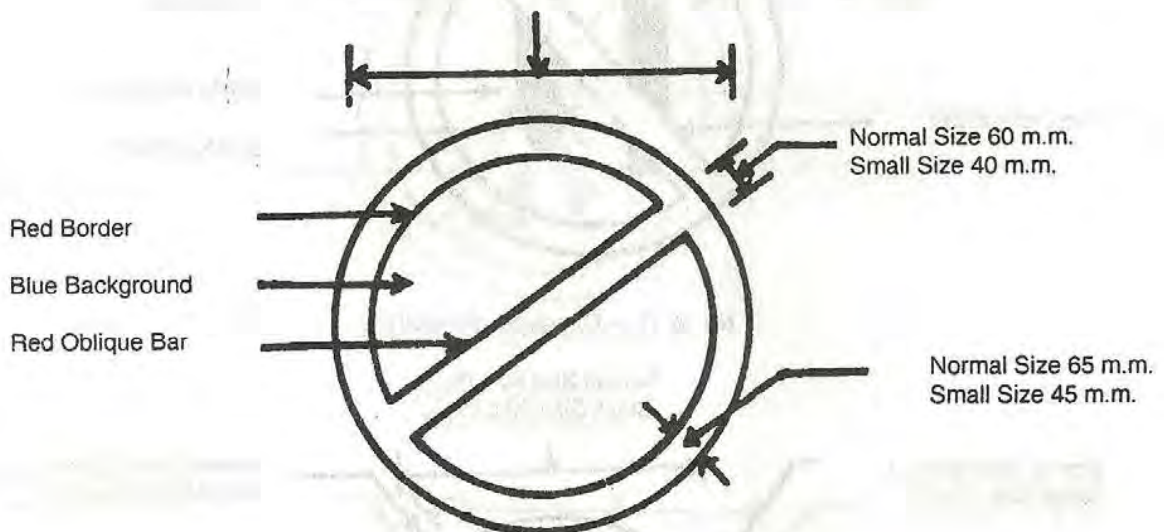

Note. A definition plate may be attached with the sign carrying the message in English and other languages as necessary, as also any additional information such as the period during which the restrictions will be in force or the particular vehicles to which it applies.

No. M 20 — No Stopping or Standing

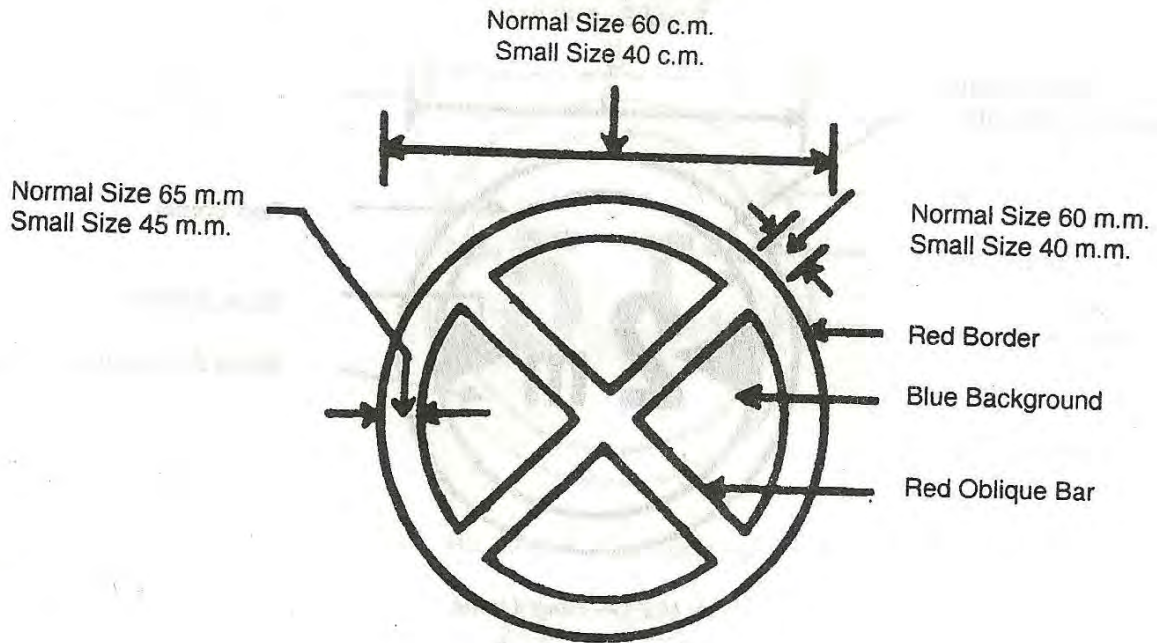

Note. A definition plate may be attached with the sign carrying the message in English and other languages as necessary, as also any additional information such as the period during which the restrictions will be in force or the particular vehicles to which it applies.

No. M 21 — Speed Limit

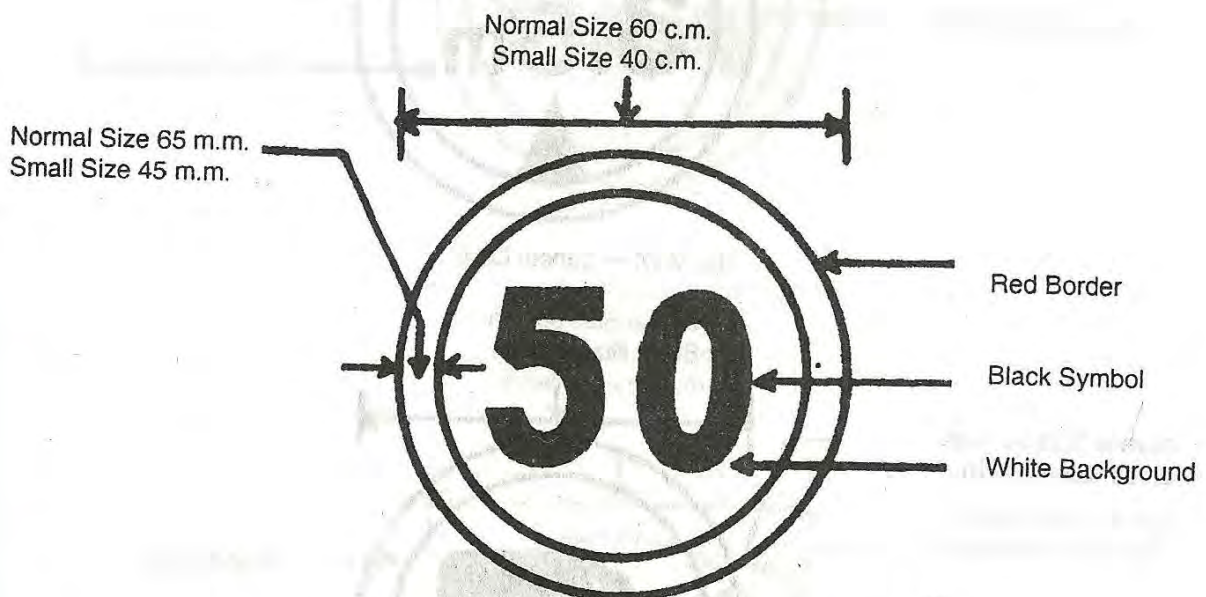

Note. Where speed limit is imposed only on certain class or classes of motor vehicles, this may be specified on a definition plate. Where in addition to general speed limit a special speed limit is imposed on motor vehicles of certain class or classes, the latter together with the class or classes of vehicles may be specified on a definition plate.

No. M 22 — Width Limit

Normal Size 60 c.m.
Small Size 40 c.m.

Normal Size 65 m.m.
Small Size 45 m.m.

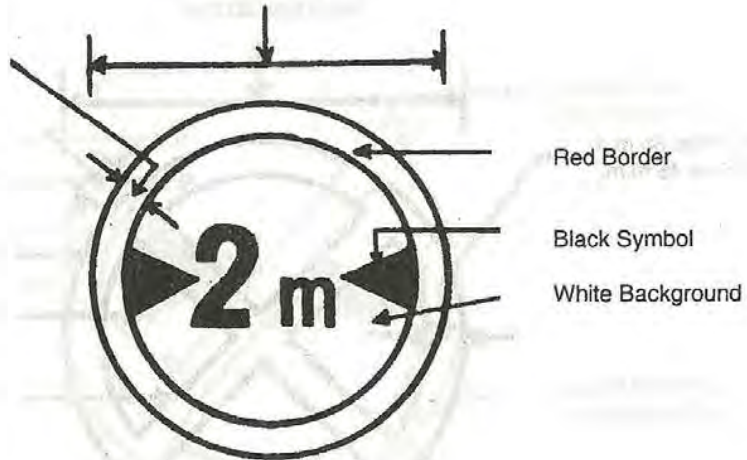

No. M 23 — Height Limit

Normal Size 60 c.m.
Small Size 40 c.m.

Normal Size 65 m.m.
Small Size 45 m.m.

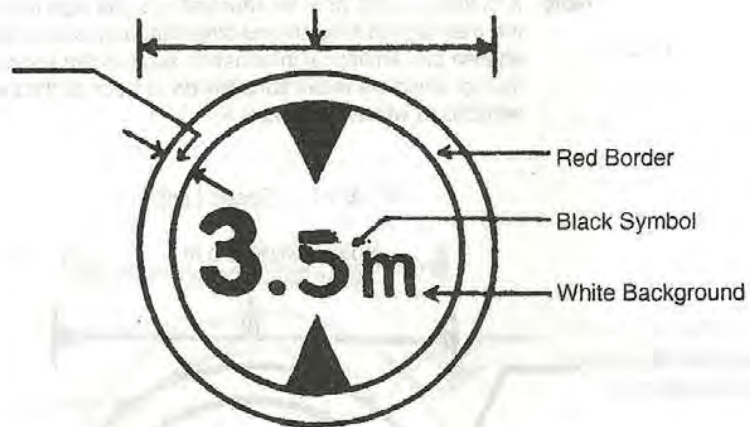

No. M 24 — Length Limit

Normal Size 60 c.m.
Small Size 40 c.m.

Normal Size 65 m.m.
Small Size 45 m.m.

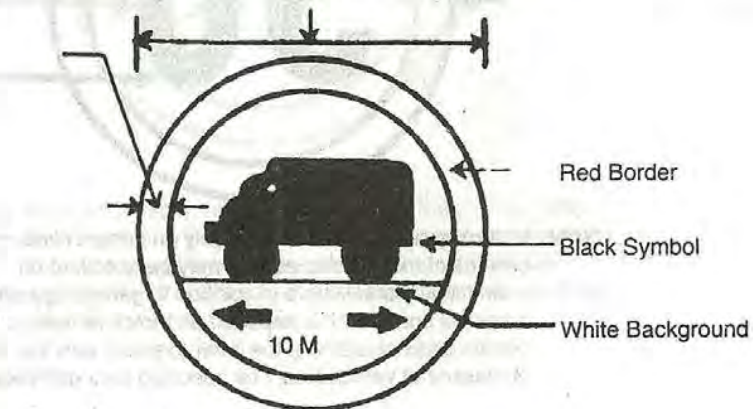

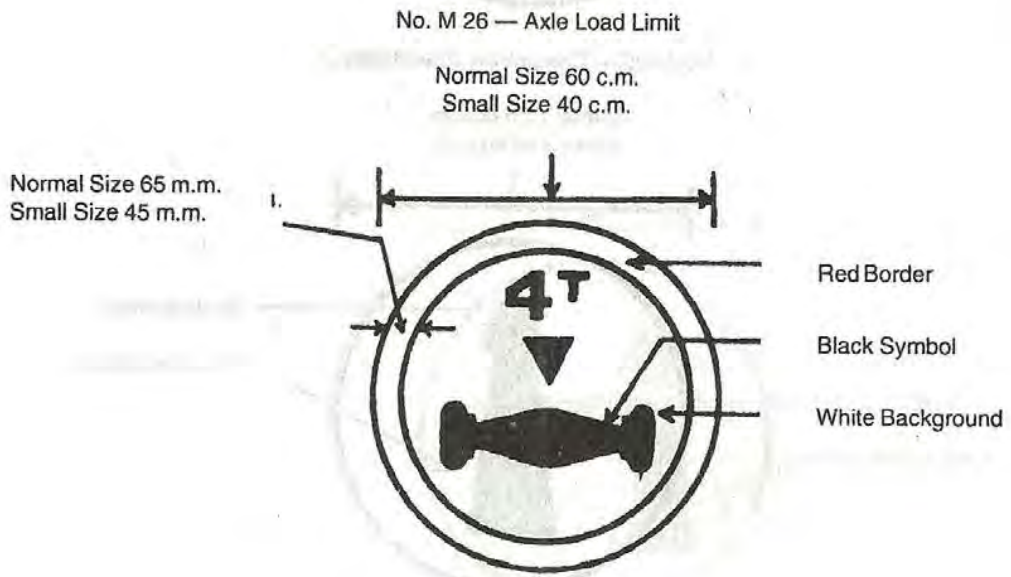
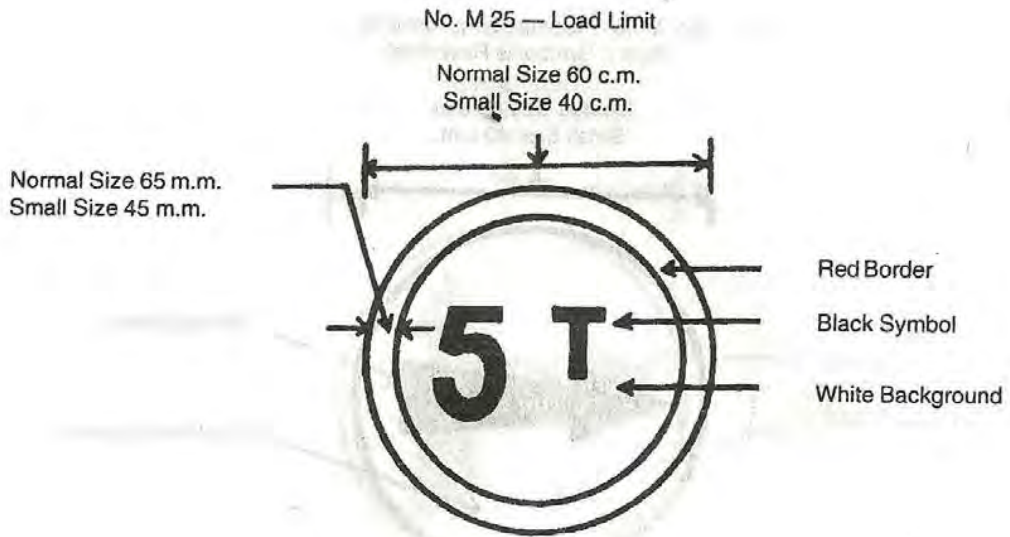

No. M 27 — Restriction Ends Sign

Normal Size 60 c.m.
Small Size 40 c.m.

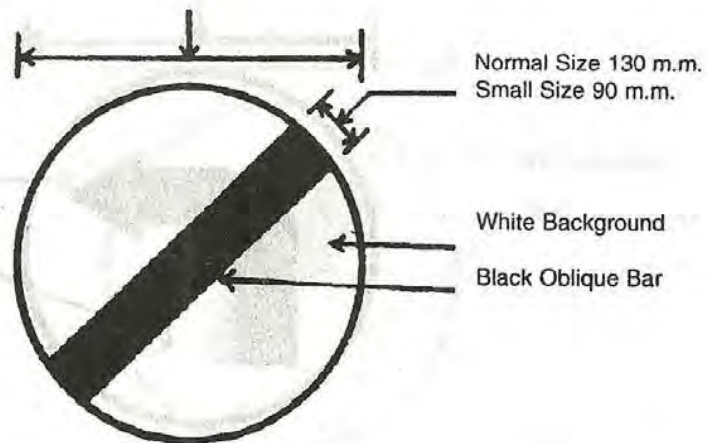

No. M 28 — Compulsory Turn Left
(Right if Symbol is Reversed)

Normal Size 60 c.m.
Small Size 40 c.m.

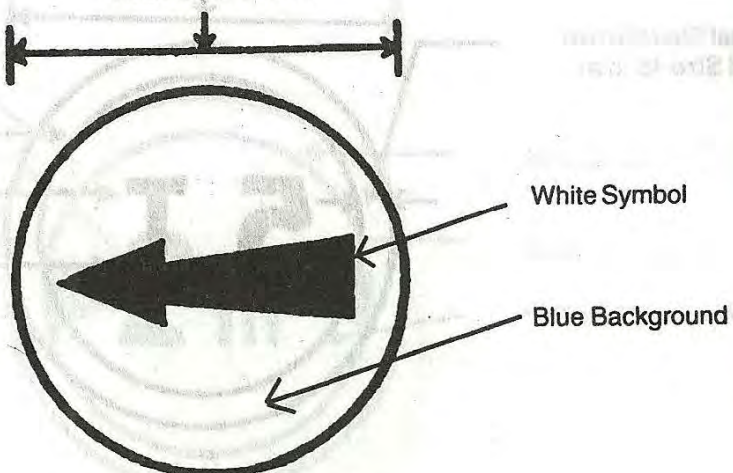

No. M 29 — Compulsory Ahead Only

Normal Size 60 c.m.
Small Size 40 c.m.

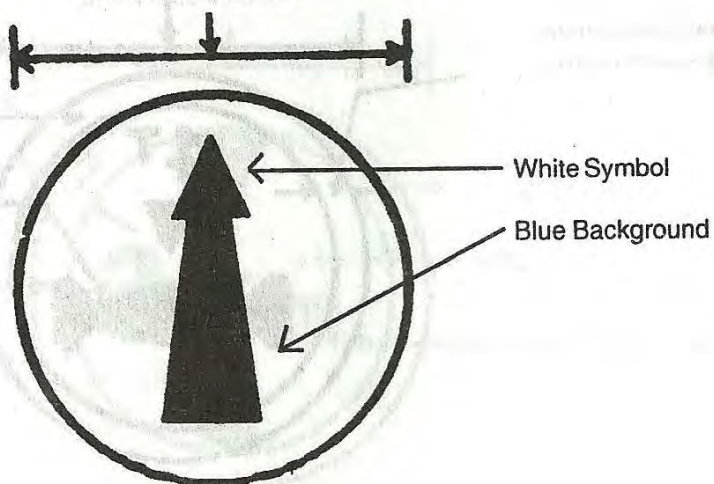

No. M 30 — Compulsory Turn Right Ahead
(Left if Symbol is Reversed)

Normal Size 60 c.m.
Small Size 40 c.m.

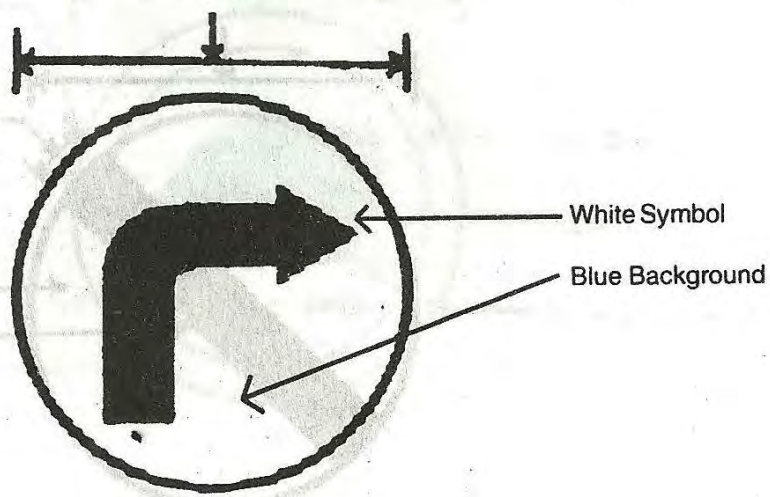

No. M31 -Compulsory Ahead or Turn Right

Normal Size 61 > c.m.
Small Size 40 c.m.

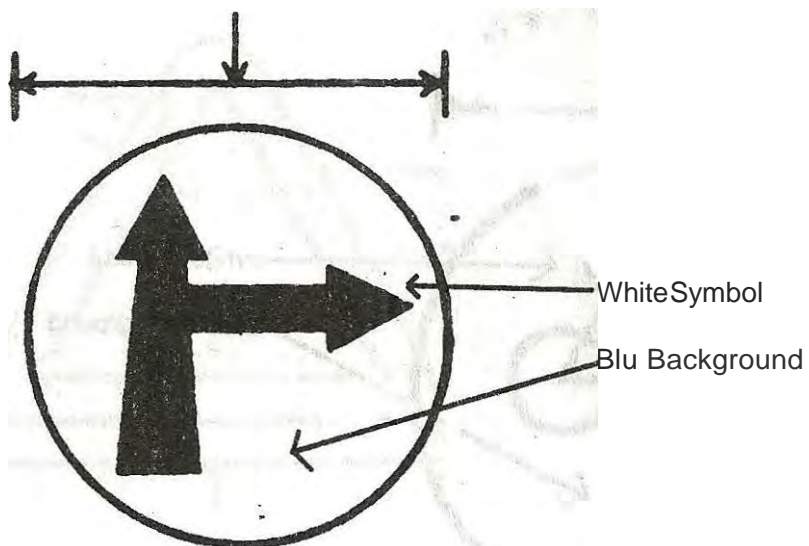

No. M32 Compulsory Ahead or Turn Left

Normal Size 60 c.m.
Small Size 40 c.m.

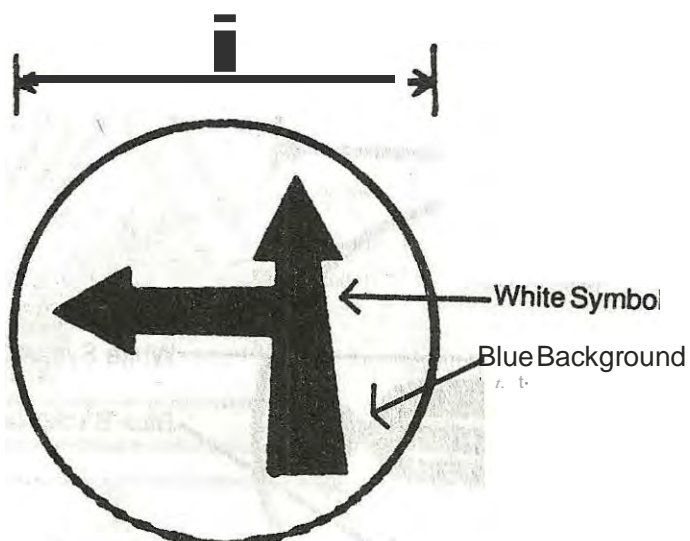

No. M33 :- Compulsory Keep Left

Normal Size 60 c.m.
Small Size 40 c.m.

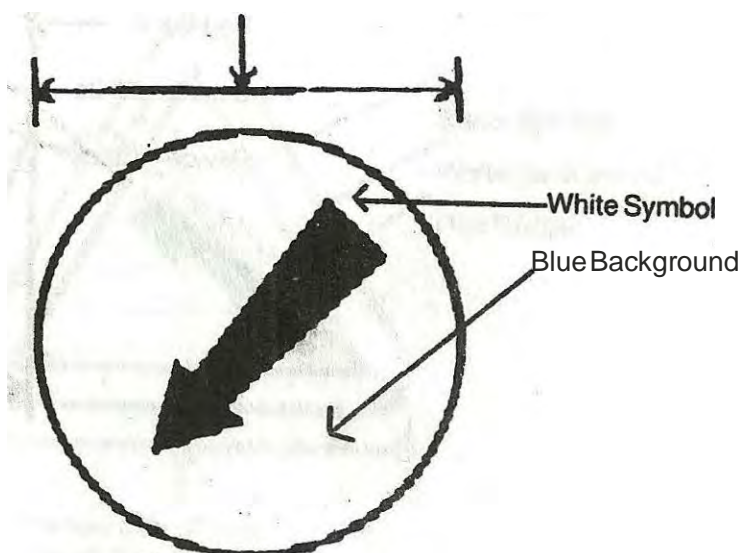

No. M 34 — Compulsory Cycle Track

Normal Size 60 c.m.
Small Size 40 c.m.

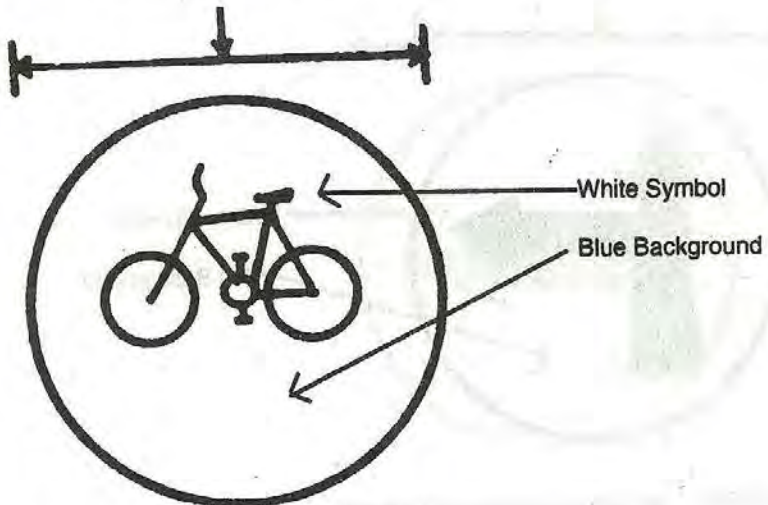

No. M 35 — Compulsory Sound Horn

Normal Size 60 c.m.
Small Size 40 c.m.

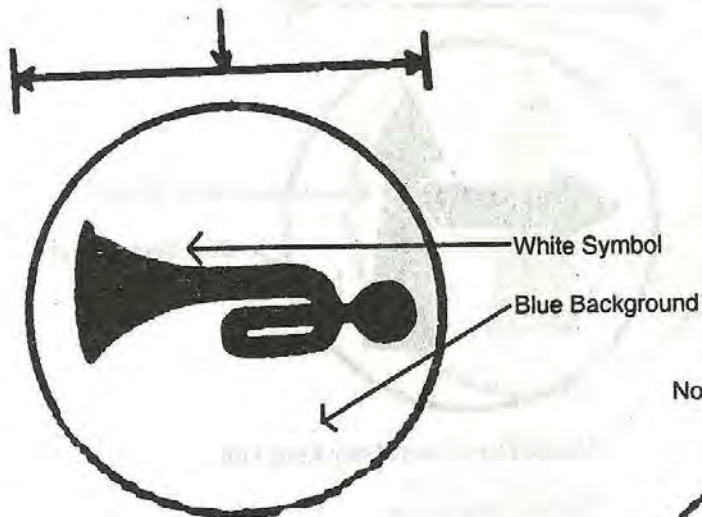

No. M 36 — Compulsory Bus Stop

Red Band
Centre—White
Device—Black

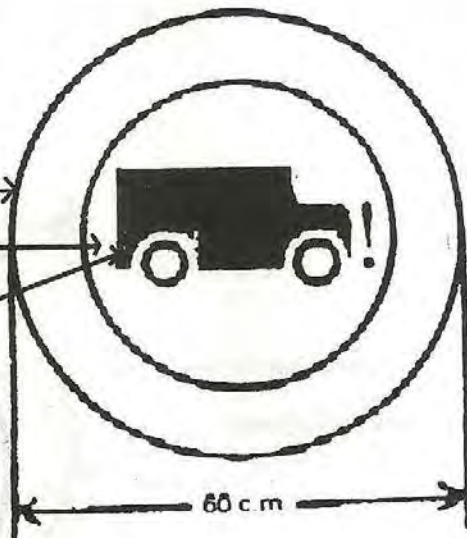

PART B
Cautionary signs of the First Schedule of The Motor Vehicles Act, 1988

No. C 1 — General Design

Normal Size 70 m.m.
 Small Size 45 m.m.

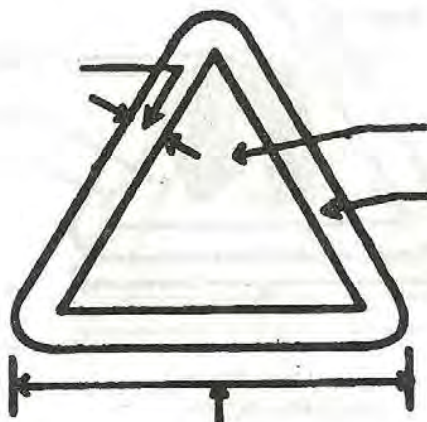

White Background

Red Border

Normal Size 90 c.m.
 Small Size 60 c.m.

No. C 2 — Right Hand Curve

Normal Size 70 m.m.
 Small Size 45 c.m.



Black Symbol

White Background

Red Border

Normal Size 90 c.m.
 Small Size 60 c.m.

No. C 3 — Left Hand Curve

Normal Size 70 m.m.
 Small Size 45 m.m.



Black Symbol

White Background

Red Border

Normal Size 90 c.m.
 Small Size 60 c.m.

No. C 4 — Right Hair Pin Bend

Normal Size 70 m.m.
Small Size 45 m.m.

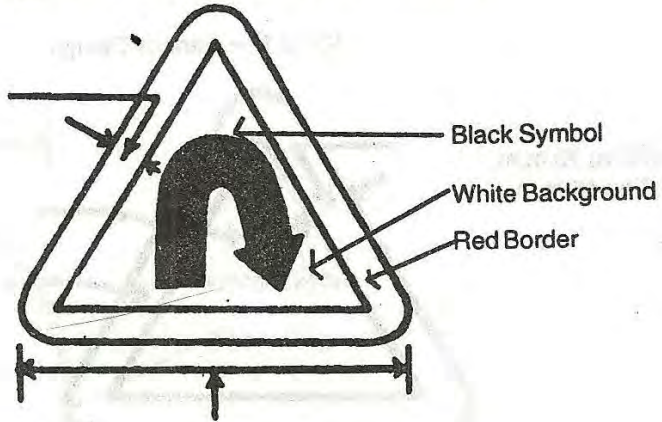

Normal Size 90 c.m.
Small Size 60 c.m.

No. C 5 — Left Hair Pin Bend

Normal Size 70 m.m.
Small Size 45 c.m.

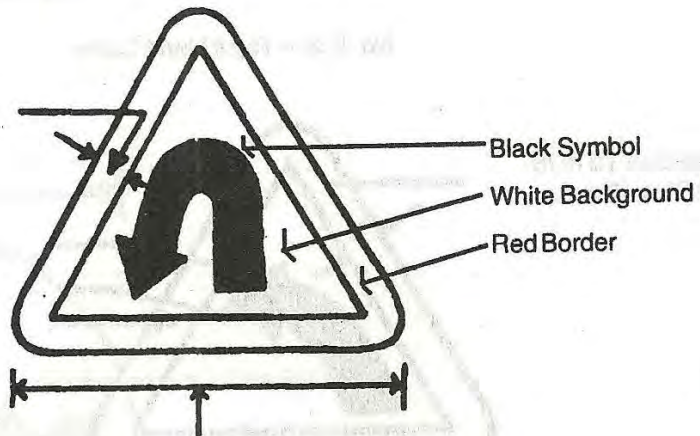

Normal Size 90 c.m.
Small Size 60 c.m.

No. C 6 — Right Reverse Bend

Normal Size 70 c.m.
Small Size 45 c.m.

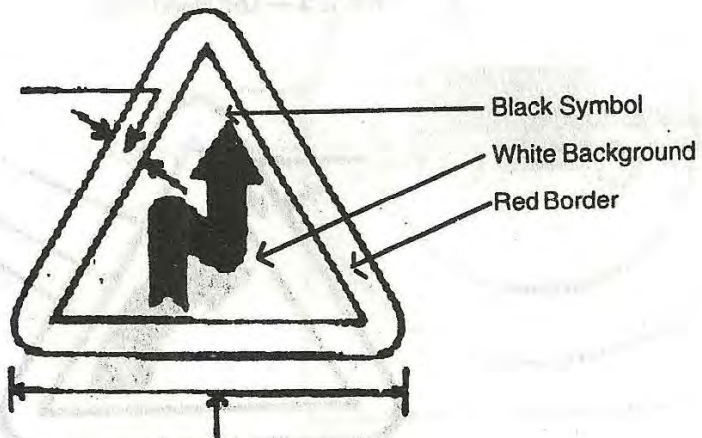

Normal Size 90 c.m.
Small Size 60 c.m.

No. C 7 — Left Reverse Bend

Normal Size 70 m.m.
Small Size 45 m.m.

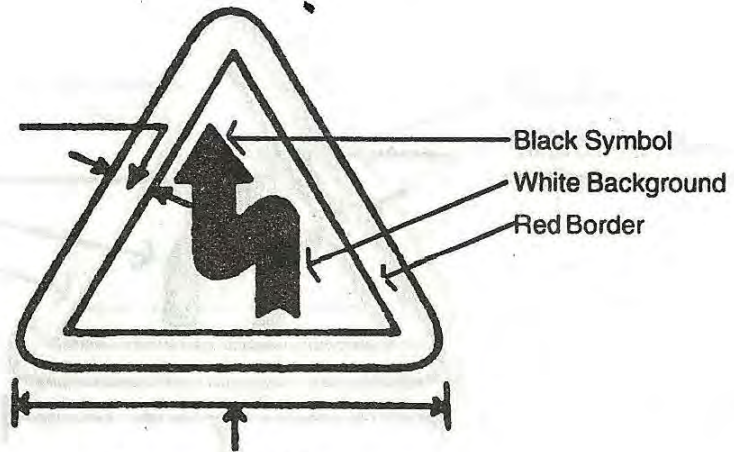

Normal Size 90 c.m.
Small Size 60 c.m.

No. C 8 — Steep Ascent

Normal Size 70 m.m.
Small Size 45 m.m.

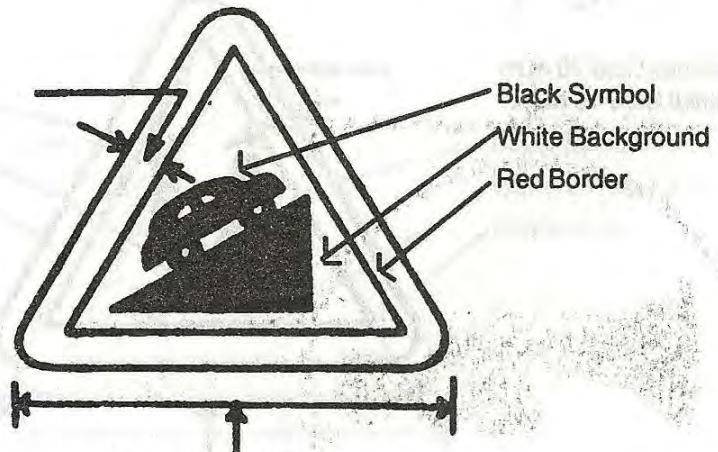

Normal Size 90 c.m.
Small Size 60 c.m.

No. C 9 — Steep Descent

Normal Size 70 m.m.
Small Size 45 m.m.

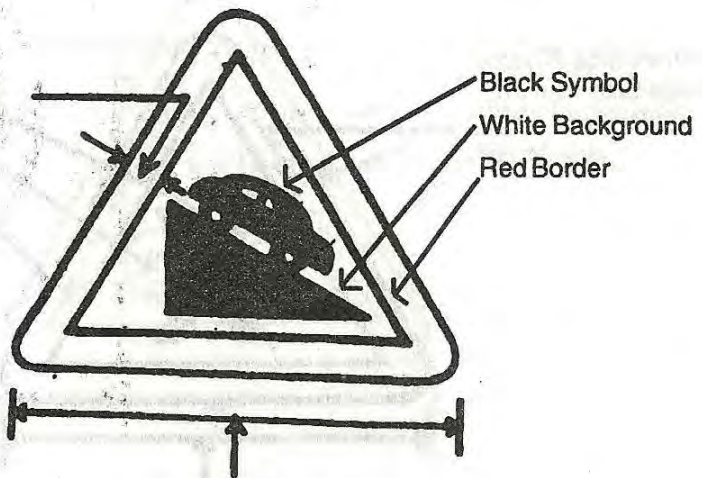

Normal Size 90 c.m.
Small Size 60 c.m.

No. C 10 — Narrow Road Ahead

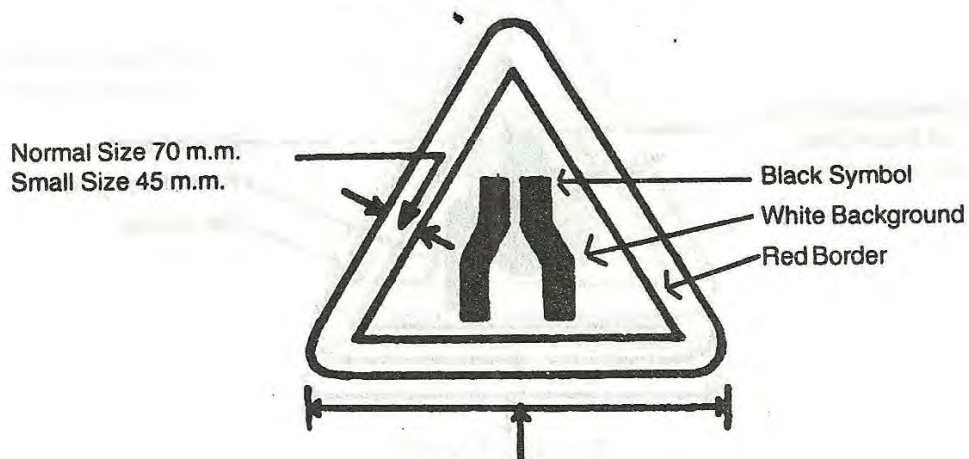

Normal Size 90 c.m.
Small Size 60 c.m.

No. C 11 - Road Widens Ahead

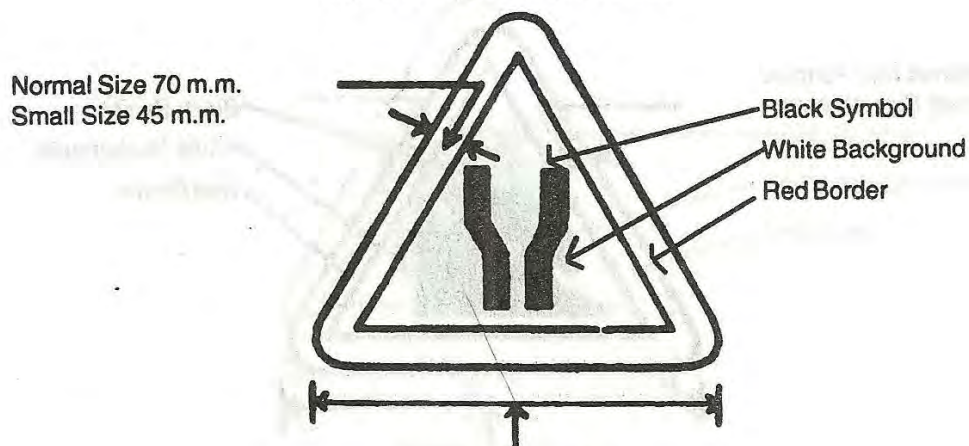

Normal Size 90 c.m.
Small Size 60 c.m.

No. C 12 — Narrow Bridge

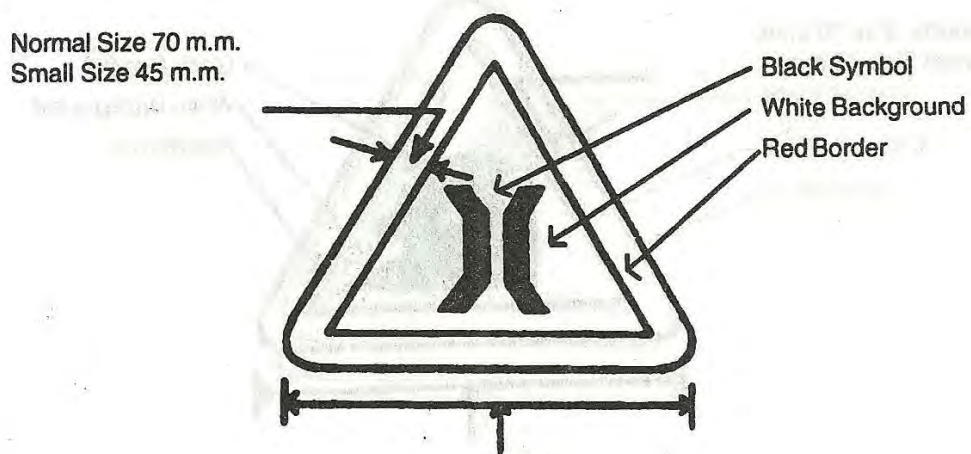

Normal Size 90 c.m.
Small Size 60 c.m.

No. C 13 — Slippery Road

Normal Size 70 m.m.
Small Size 45 m.m.

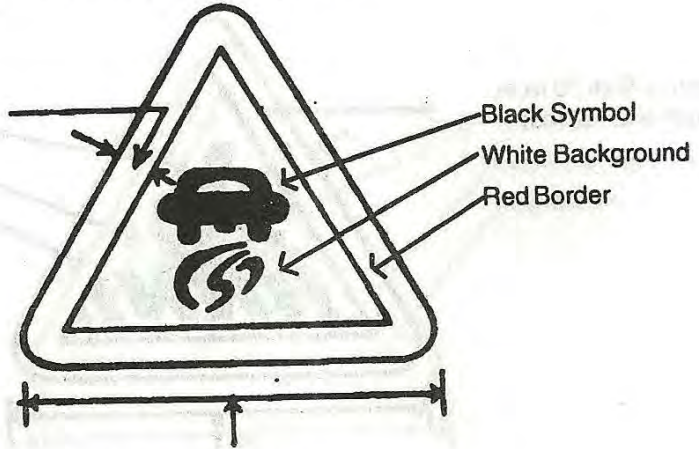

Normal Size 90 c.m.
Small Size 60 c.m.

No. C 14 — Loose Gravel

Normal Size 70 m.m.
Small Size 45 m.m.

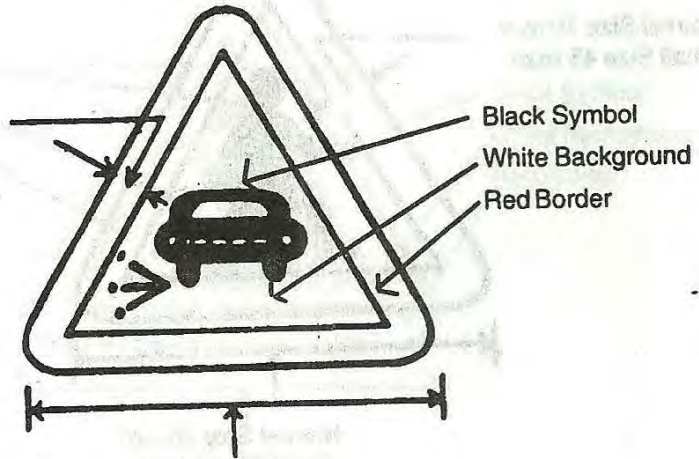

Normal Size 90 c.m.
Small Size 60 c.m.

No. C 15 — Cycle Crossing

Normal Size 70 m.m.
Small Size 45 m.m.

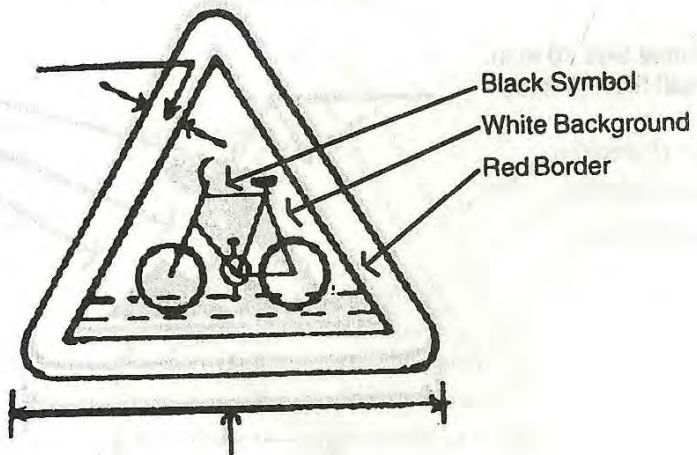

Normal Size 90 c.m.
Small Size 60 c.m.

No. C 16 — Pedestrian Crossing



No. C 17 — School Ahead

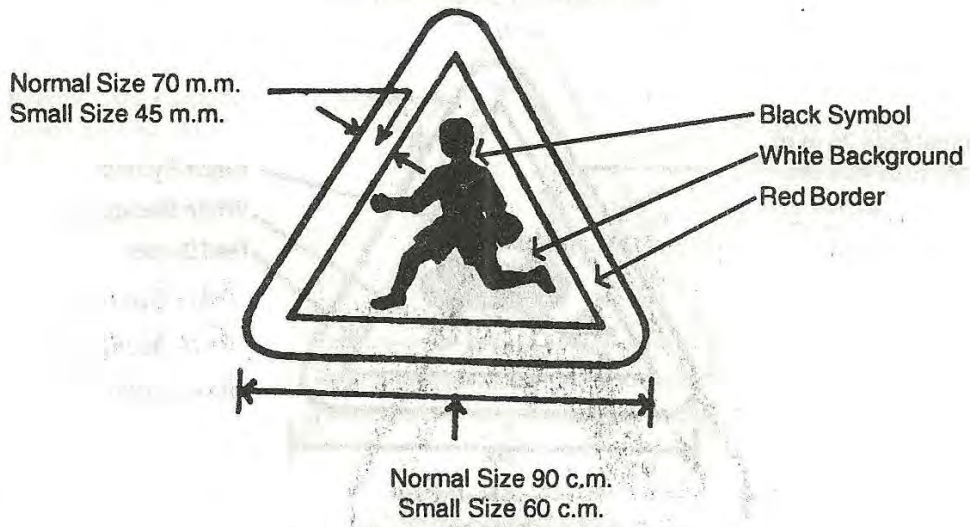

No. C 18 — Men At Work



No. C 19 — Cattle

Normal Size 70 m.m.
Small Size 45 m.m.

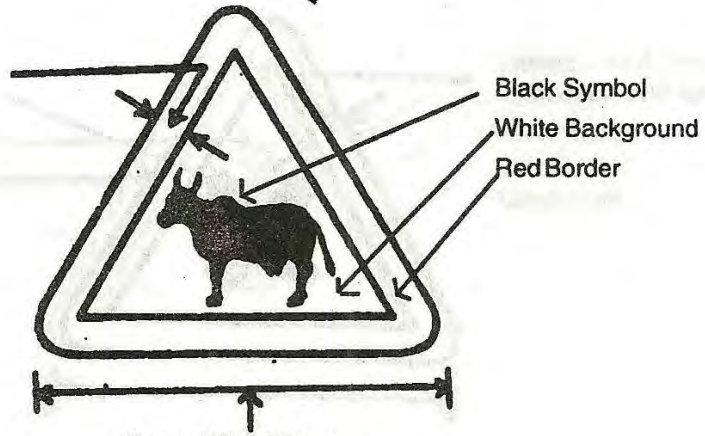

Normal Size 90 c.m.
Small Size 60 c.m.

No. C 20 — Falling Rocks

Normal Size 70 m.m.
Small Size 45 m.m.

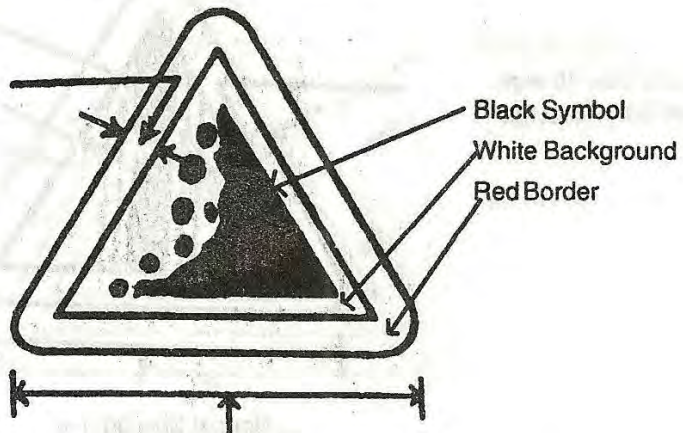

Normal Size 90 c.m.
Small Size 60 c.m.

No. C 21 — Ferry

Normal Size 70 m.m.
Small Size 45 m.m.

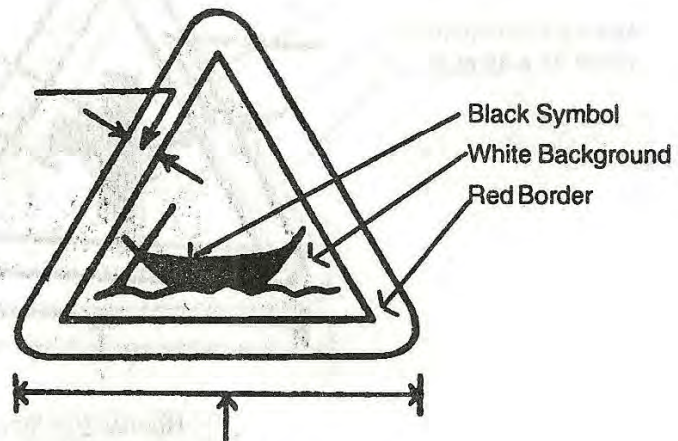

Normal Size 90 c.m.
Small Size 60 c.m.

No. C 22 — Cross Road

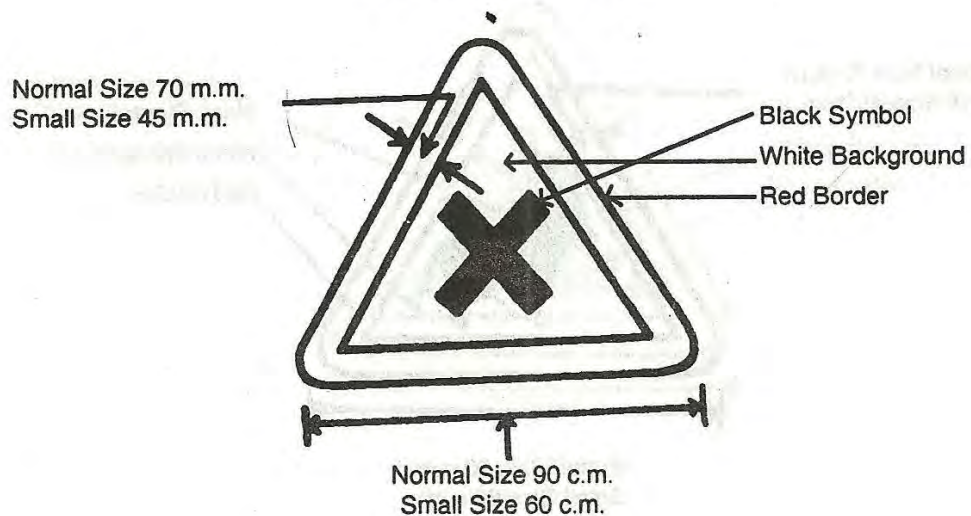

No. C 23 — Gap in Median

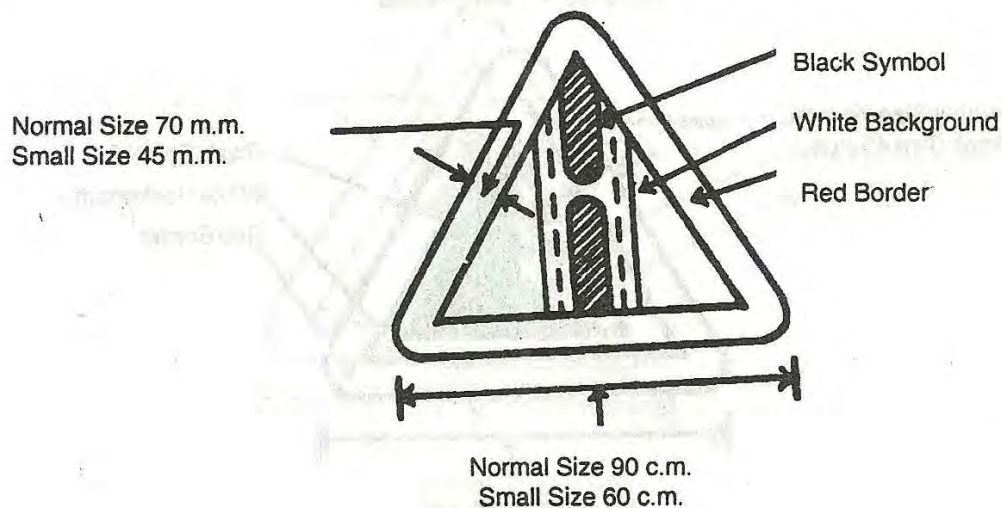

No. C 24 — Side Road Right

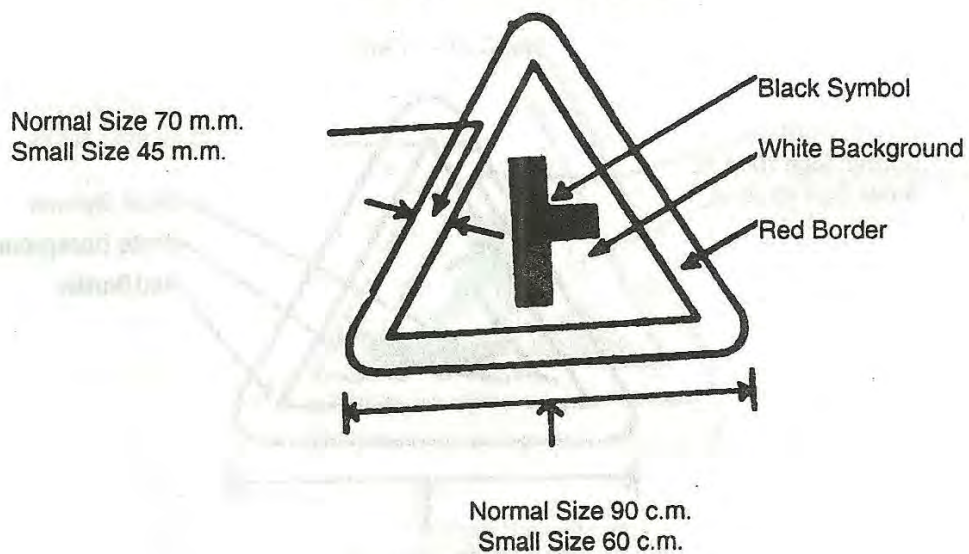

No. C 25 — Side Road Left

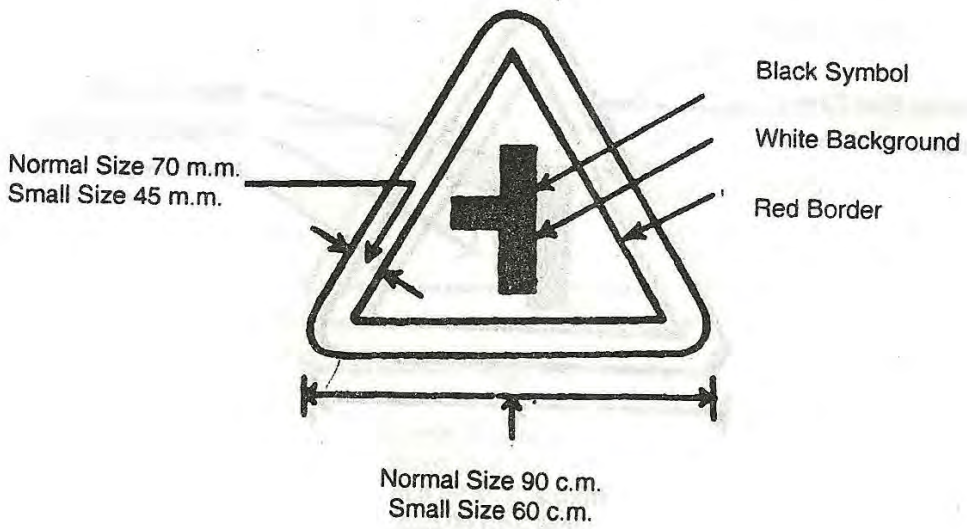

No. C 26A — Y—Intersection

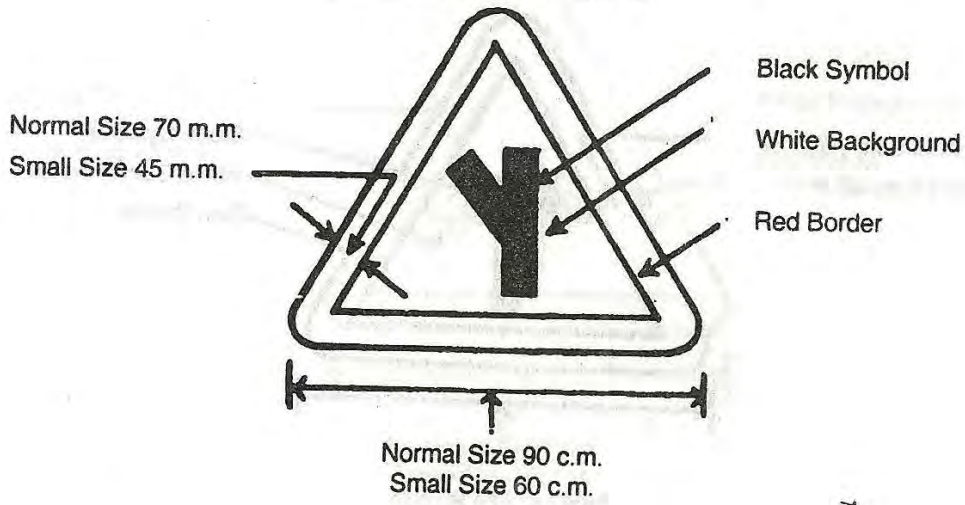

No. C 26B — Y— Intersection

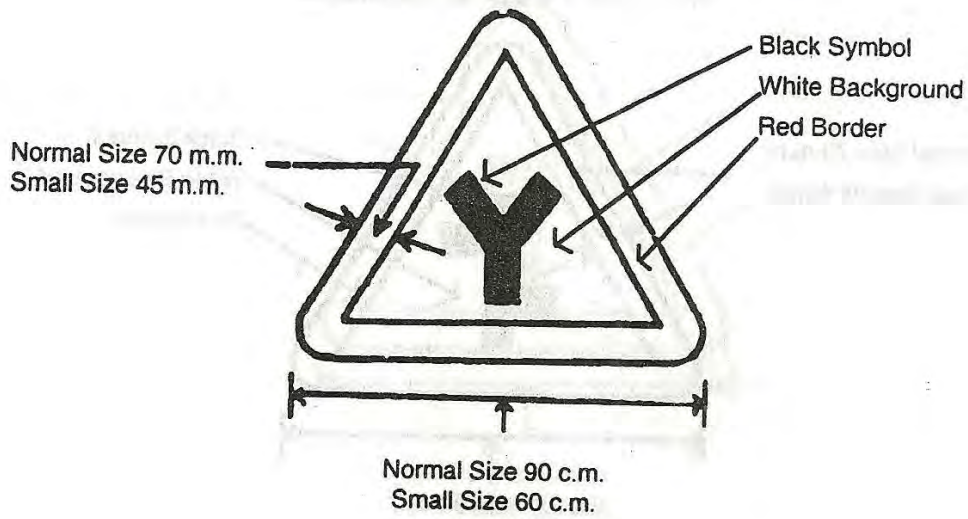

No. C 26C — Y — Intersection

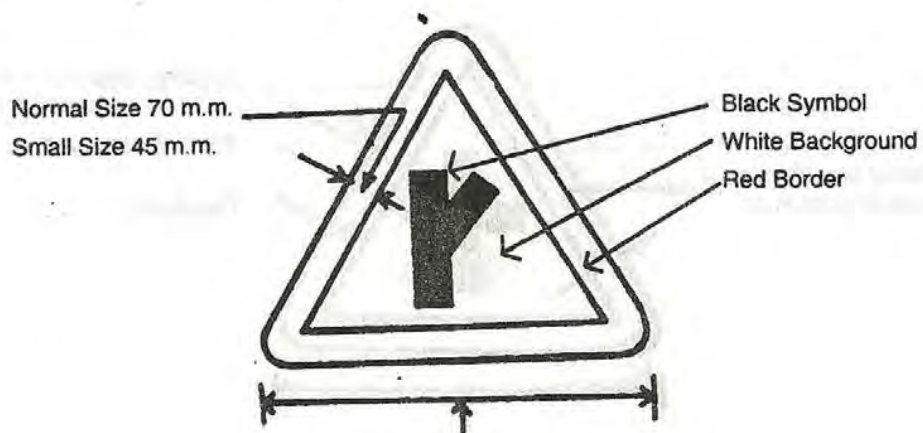

Normal Size 90 c.m.
Small Size 60 c.m.

No. C 27 — T — Intersection

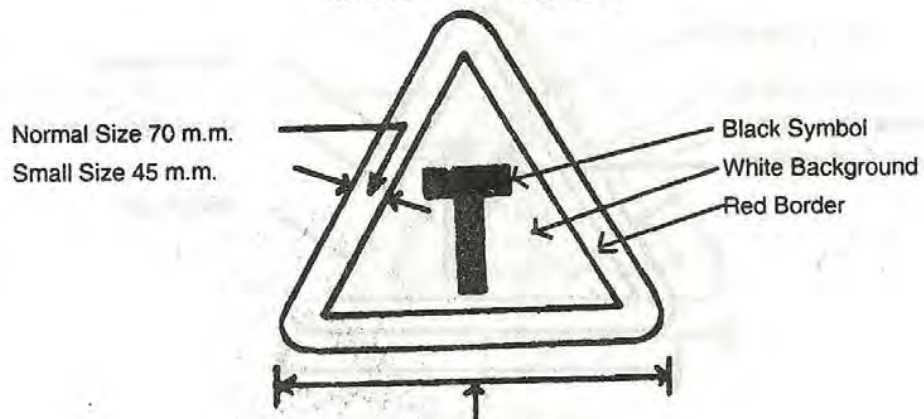

Normal Size 90 c.m.
Small Size 60 c.m.

No. C 28A — Staggered Intersection

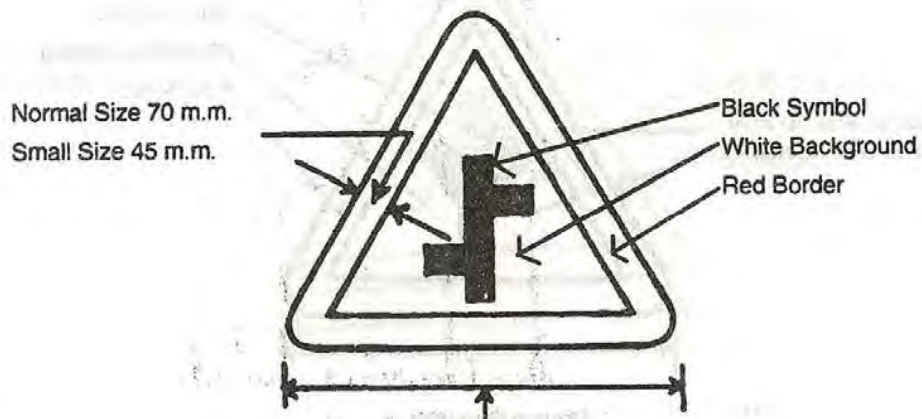

Normal Size 90 c.m.
Small Size 60 c.m.

No. C 28B — Staggered intersection

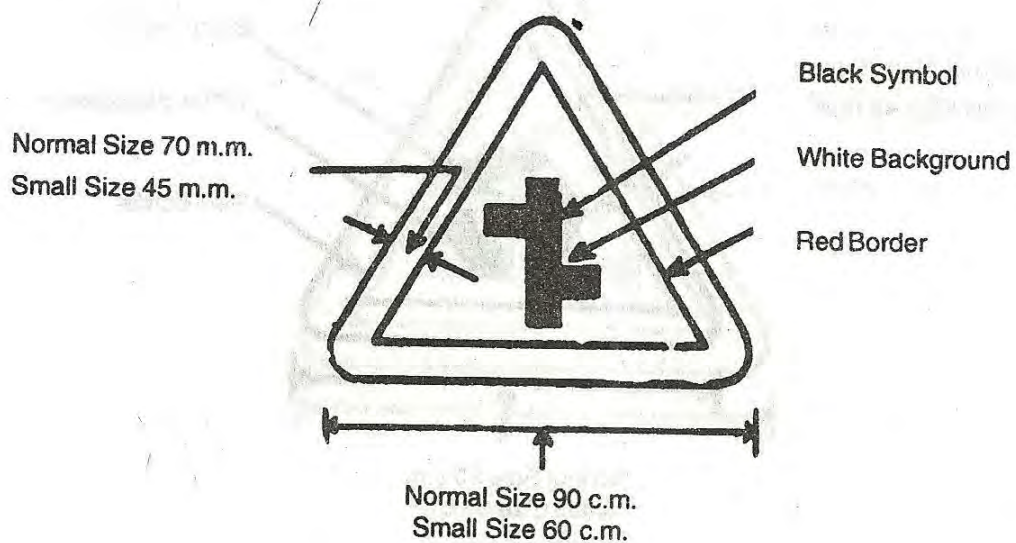

No. C 29A — Major Road Ahead

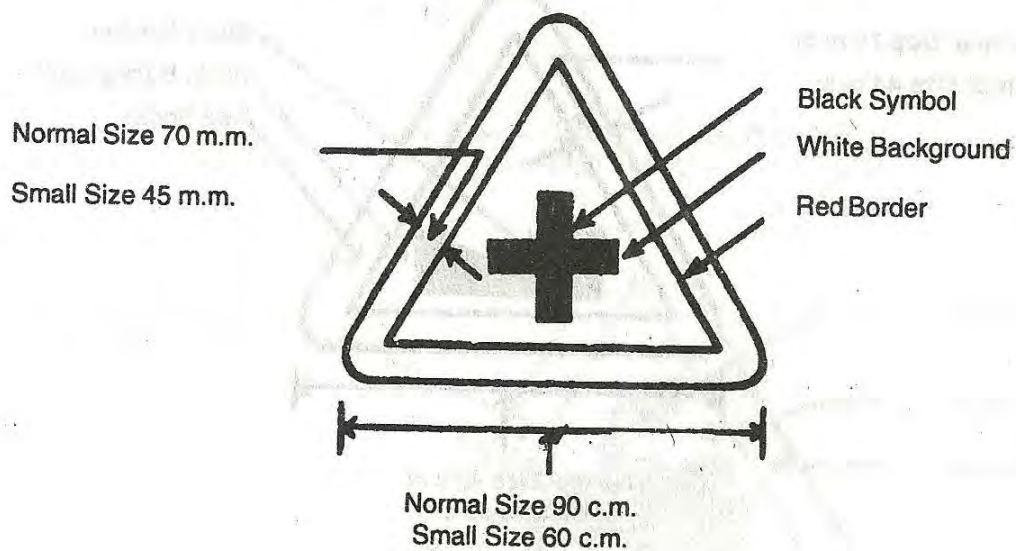

No. C 29B — Major Road Ahead

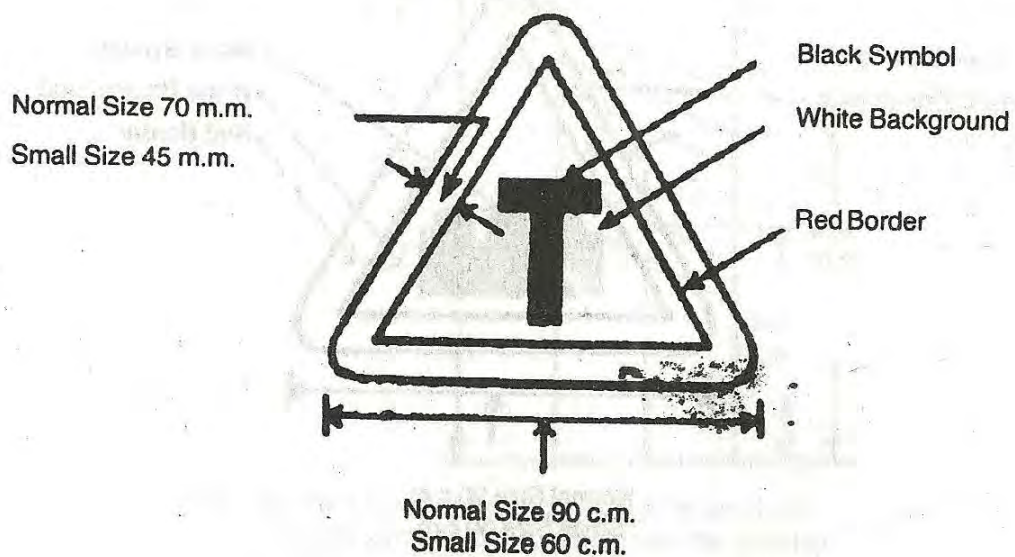

No. C 30 — Roundabout

Normal Size 70 m.m.
Small Size 45 m.m.

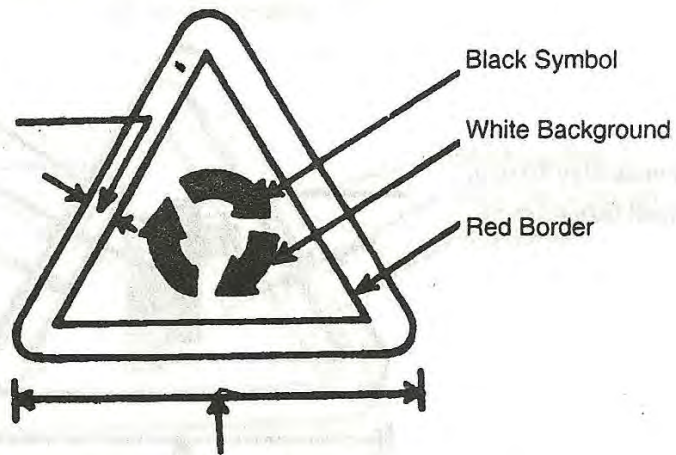

Normal Size 90 c.m.
Small Size 60 c.m.

No. C 31 — Dangerous Dip

Normal Size 70 m.m.
Small Size 45 m.m.

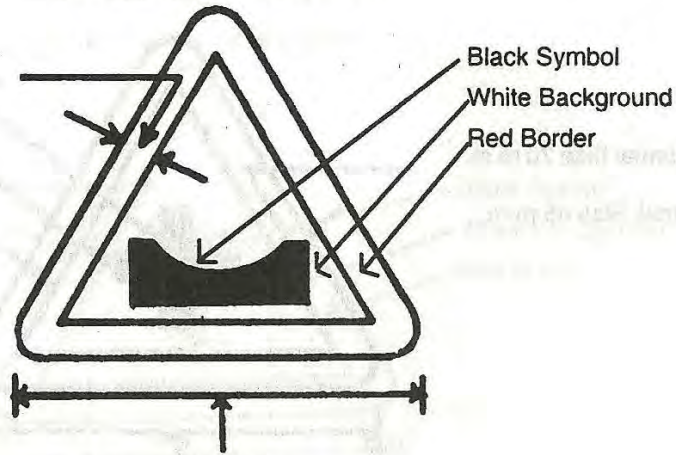

Normal Size 90 c.m.
Small Size 65 c.m.

No. C 32 — Hump or Rough Road

Normal Size 70 m.m.
Small Size 45 m.m.

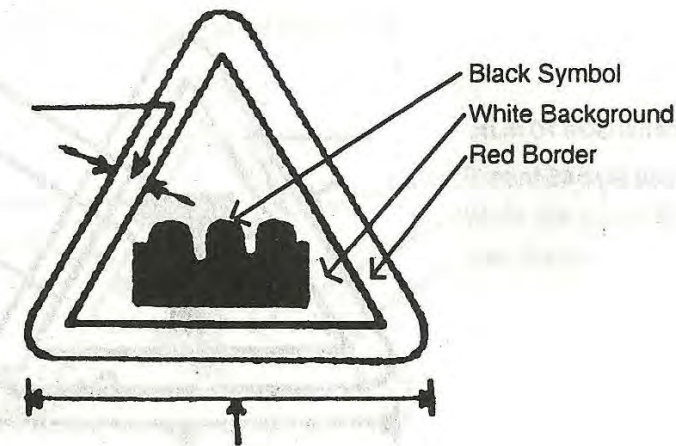

Normal Size 90 c.m.
Small Size 60 c.m.

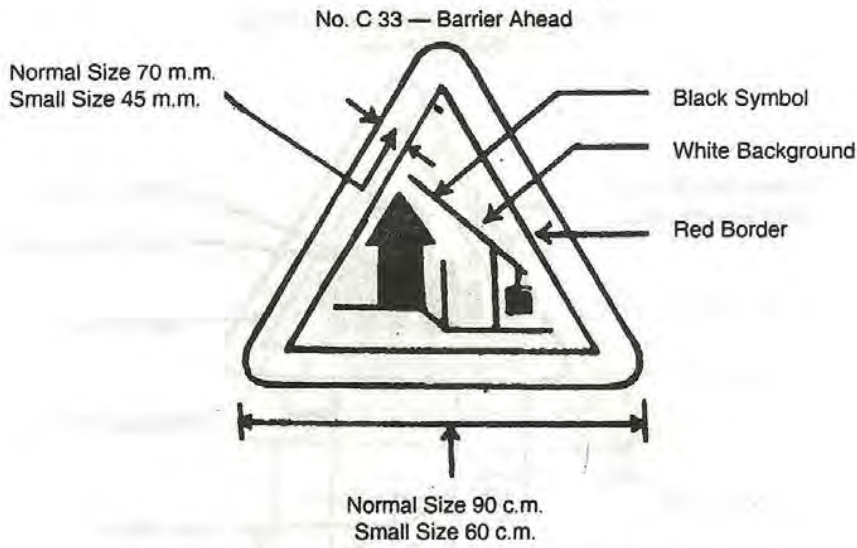

Note. A Definition Plate may be attached with the sign indicating the Distance to the Barrier and any other instructions.

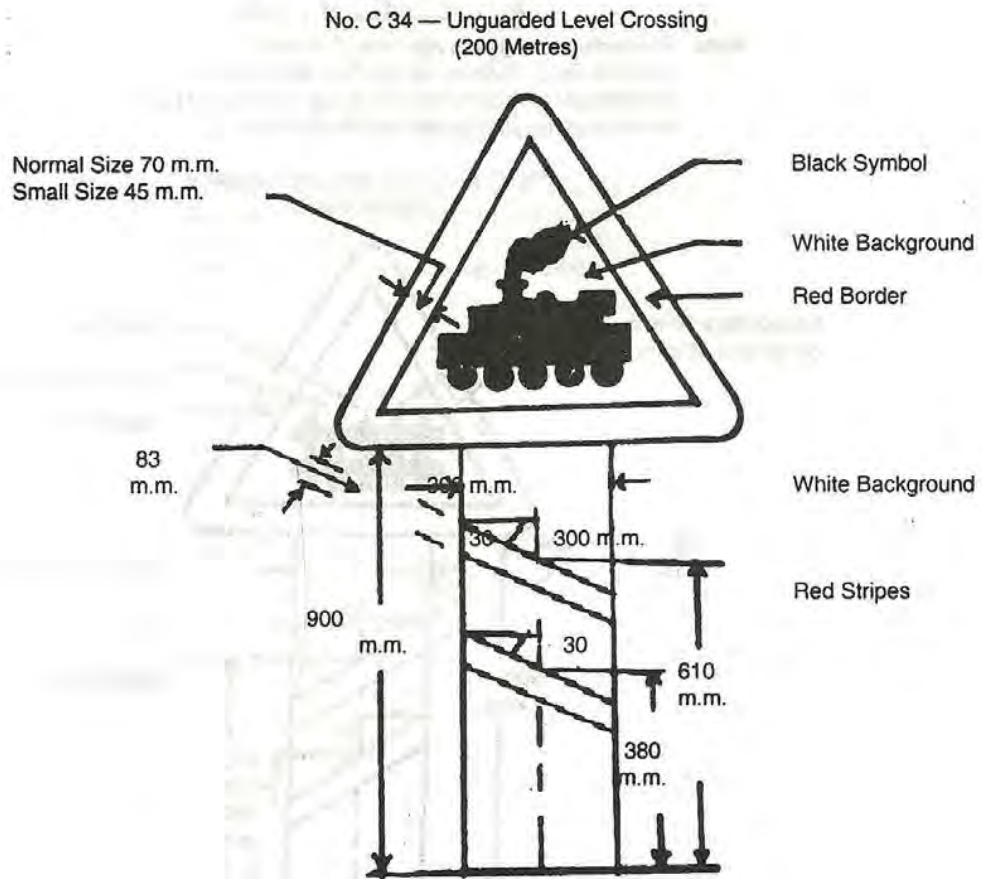

Note. For each crossing both sign Nos. C 34 and C 35 are to be used. Distance of sign from the crossing is indicated in brackets below the sign heading.

No. C 35 — Unguarded Level Crossing
(50-100 Metres)

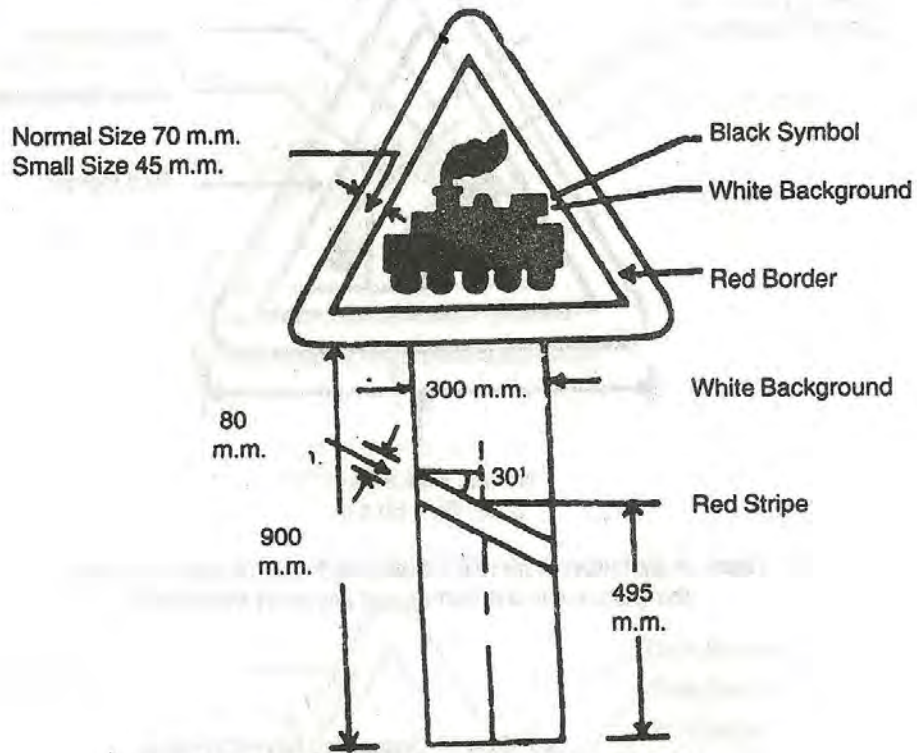

Note. For each crossing both sign Nos. C 34 and C 35 are to be used. Distance of sign from the crossing is indicated in brackets below the sign heading. In hilly terrain distance may be reduced to 30-60 m.

No. C 36 — Guarded Level Crossing
(200 Metres)

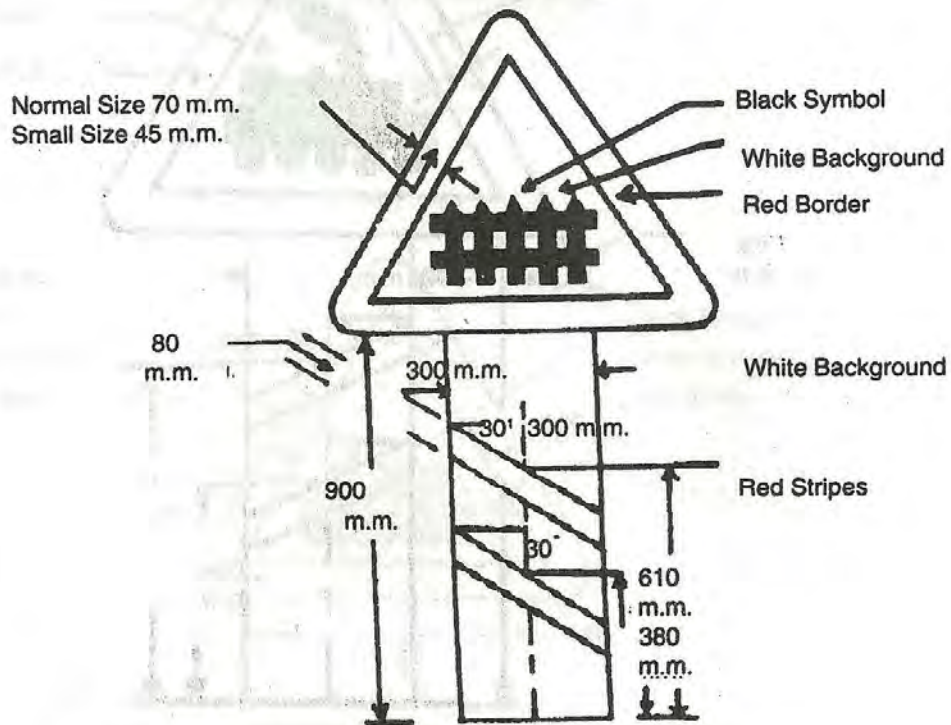

Note. For each crossing both sign Nos. C 36 and C 37 are to be used. Distance of sign from crossing is indicated in brackets below the sign heading.

No. C 37 — Guarded Level Crossing
(50—100 Metres)

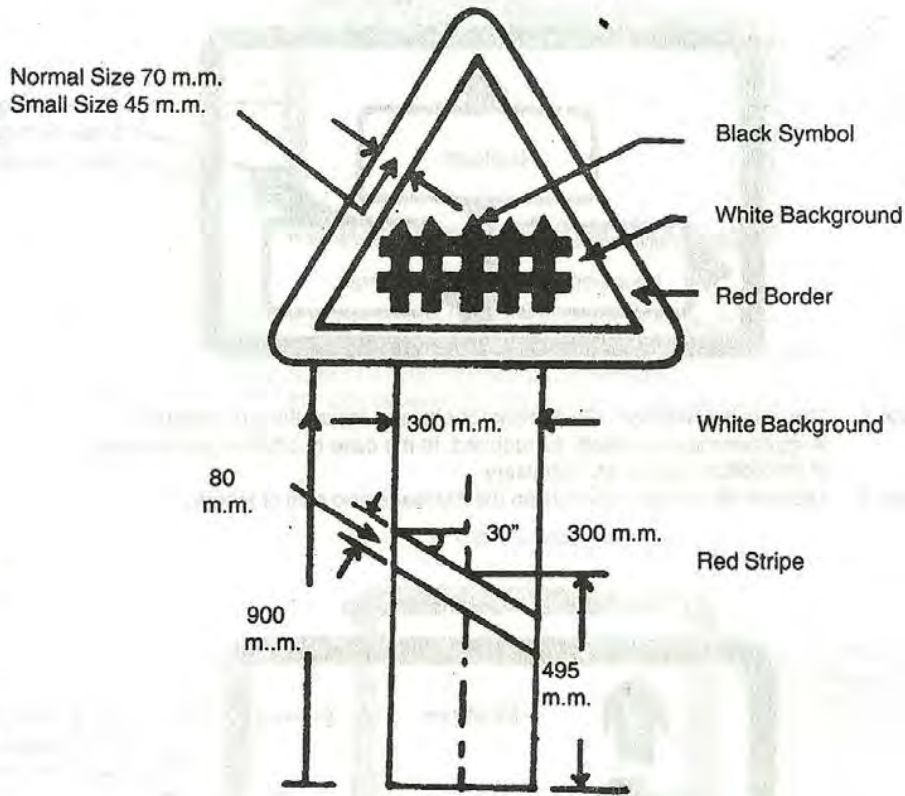

Note. For each crossing, both sign Nos. C 36 and C 37 are to be used. Distance of sign from the crossing is indicated in brackets below the sign heading. In hilly terrain distance may be reduced to 30-60 m.

PART C
Informatory signs of the First Schedule of The Motor Vehicles Act, 1988
 No. E 1 — Advance Direction sign

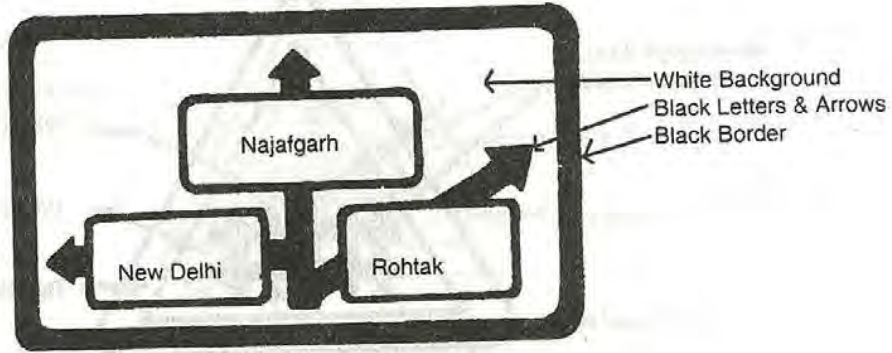

- Note 1.** The sign is illustrative. On National Highways, inscriptions in regional languages may be added as required. In the case of other roads languages of inscription may be as necessary.
- Note 2.** The size of the sign depends on the message and size of letters.

No. E 2 — Destination Sign

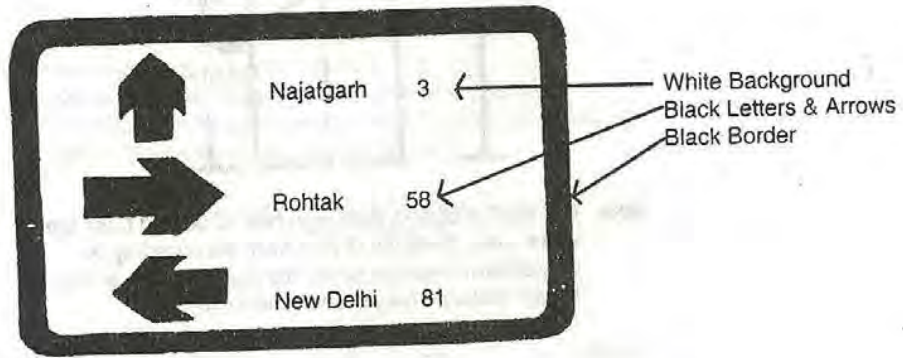

- Note 1.** The sign is illustrative. On National Highways, inscriptions in regional languages may be added as required. In the case of other roads languages of inscription may be as necessary.
- Note 2.** The size of the sign depends on the message and size of letters.

No. E 3 — Direction Sign

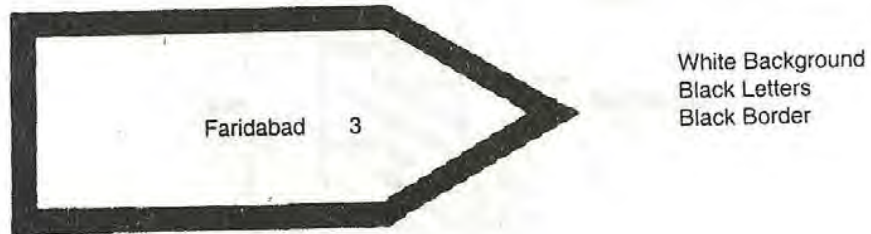

- Note 1.** The sign is illustrative. On National Highways, inscriptions in regional languages may be added as required. In the case of other roads languages of inscription may be as necessary.
- Note 2.** The size of the sign depends on the message and size of letters.

No. E 4 — Re-Assurance Sign

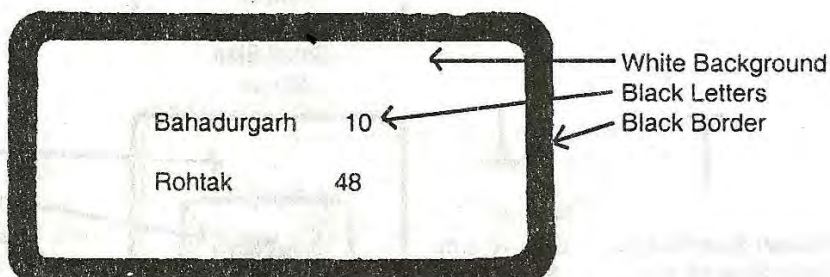

- Note 1.** The sign is illustrative. On National Highways, inscriptions in regional languages may be added as required. In the case of other roads languages of inscription may be as necessary.
- Note 2.** The size of the sign depends on the message and size of letters.

No. E 5 — Place Identification Sign

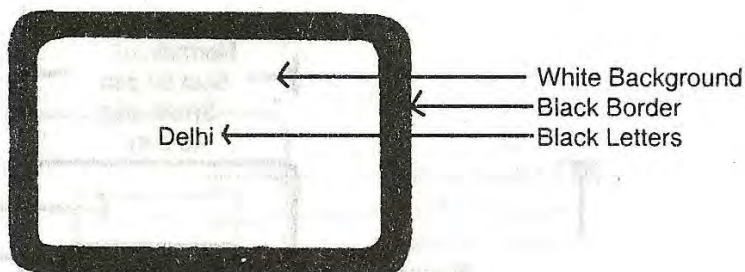

- Note 1.** The sign is illustrative. On National Highways, inscriptions in regional languages may be added as required. In the case of other roads languages of inscription may be as necessary.
- Note 2.** The size of the sign depends on the message and size of letters.

No. E 6 — Public Telephone

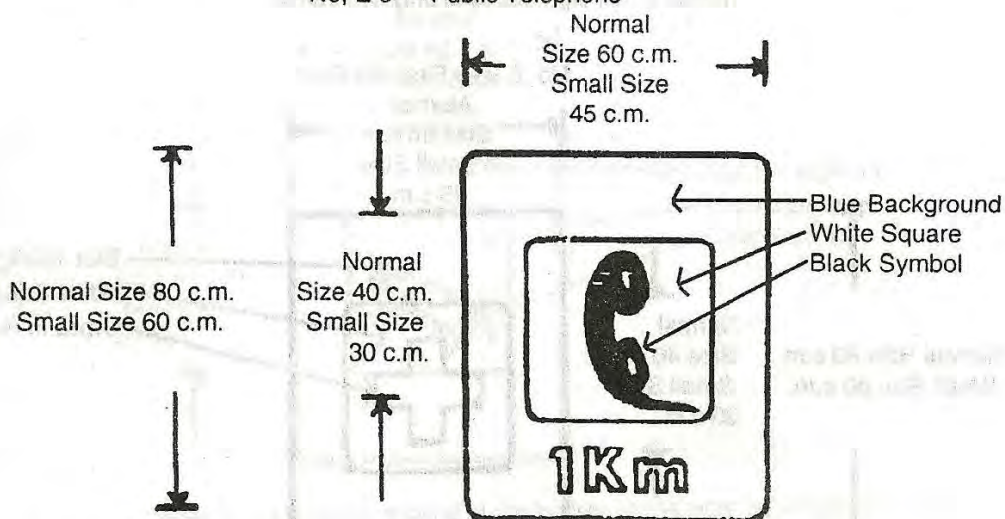

- Note.** On the blue band at the bottom of the sign, the distance to the facility or the direction may be inscribed in white. Such inscription shown in the sign above is only illustrative.

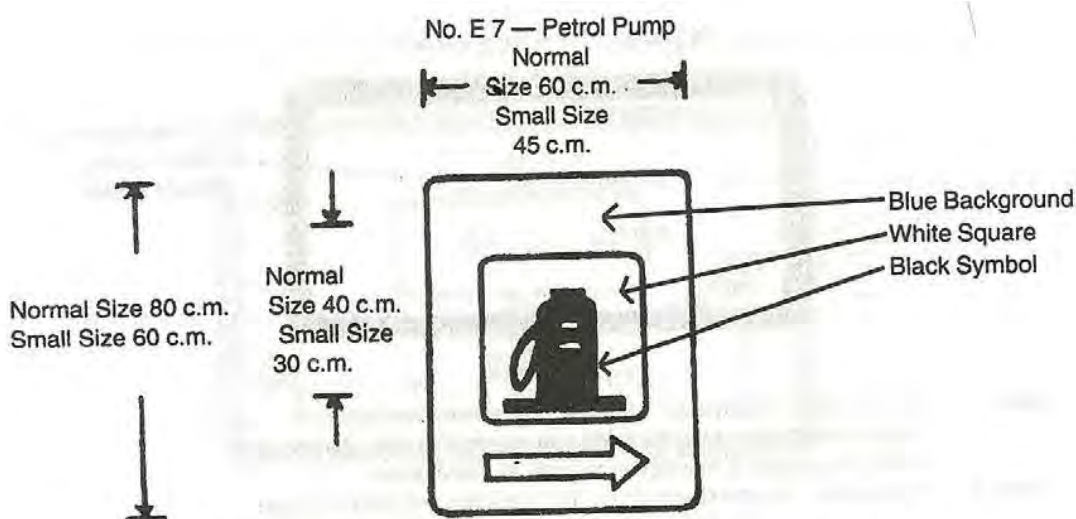

Note. On the blue band at the bottom of the sign, the distance to the facility or the direction may be inscribed in white. Such inscription shown in the sign above is only illustrative.

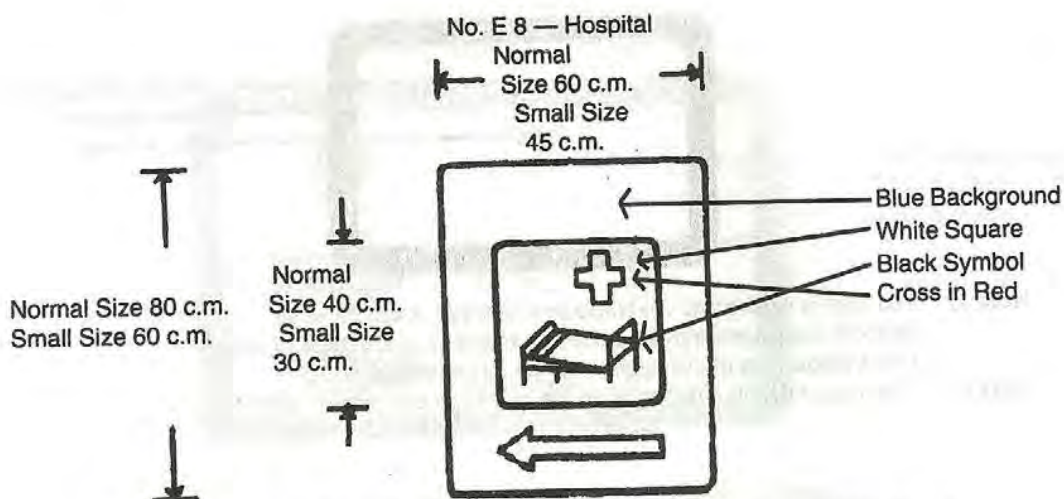

Note. On the blue band at the bottom of the sign, the distance to the facility or the direction may be inscribed in white. Such inscription shown in the sign above is only illustrative.

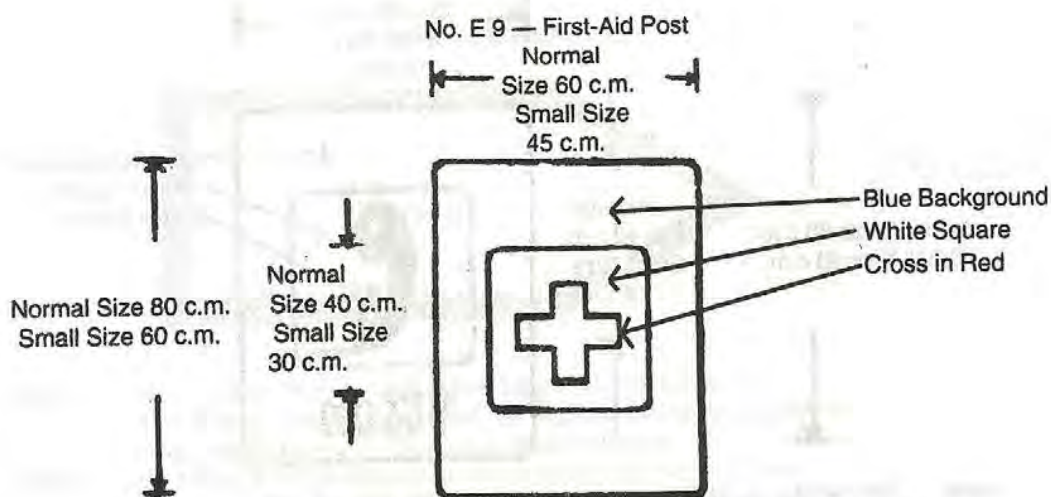

Note. On the blue band at the bottom of the sign, the distance to the facility or the direction may be inscribed in white.

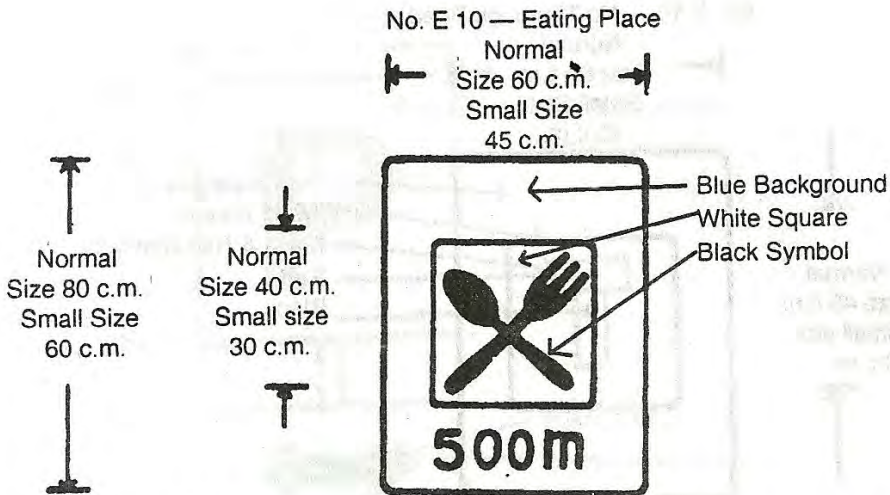

Note. On the blue band at the bottom of the sign, the distance to the facility or the direction may be inscribed in white. Such inscription shown in the sign above is only illustrative.

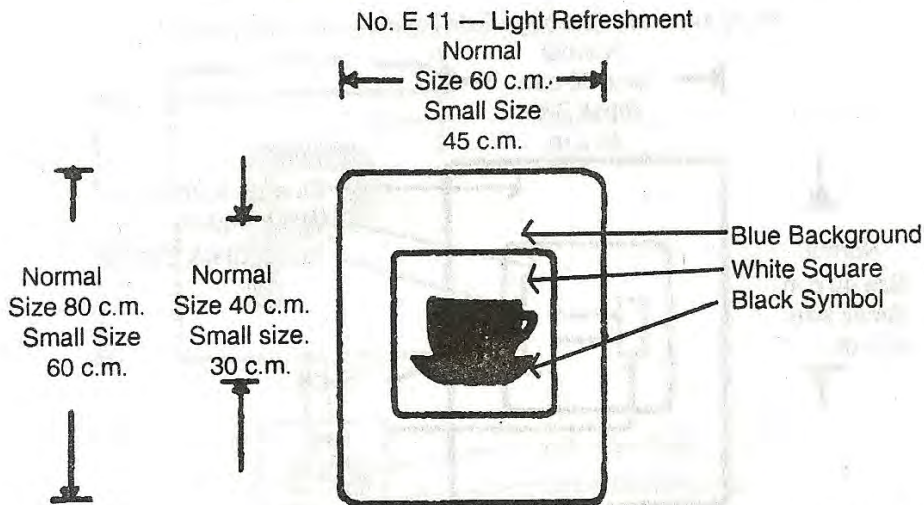

Note. On the blue band at the bottom of the sign, the distance to the facility or the direction may be inscribed in white.

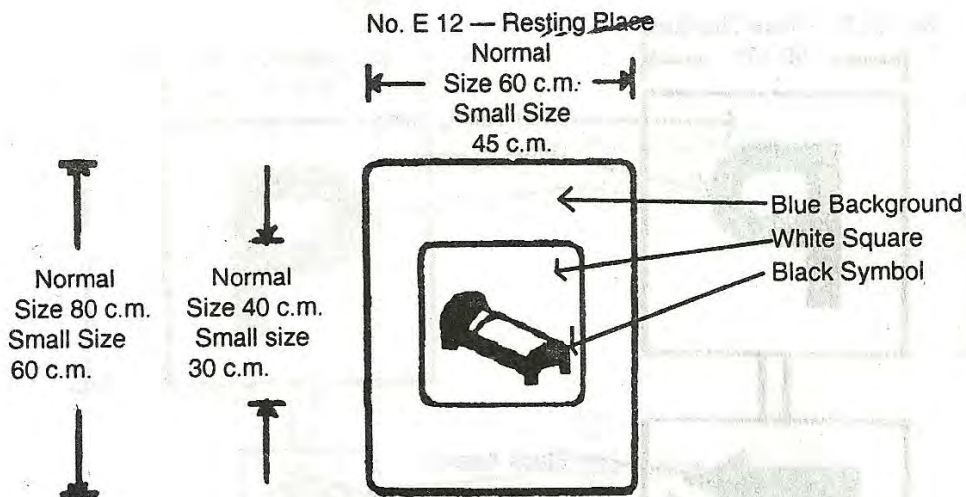

Note 1. On the blue band at the bottom of the sign, the distance to the facility or the direction may be inscribed in white.

Note 2. A definition plate may be attached indicating whether the place is rest house, hotel or motel.

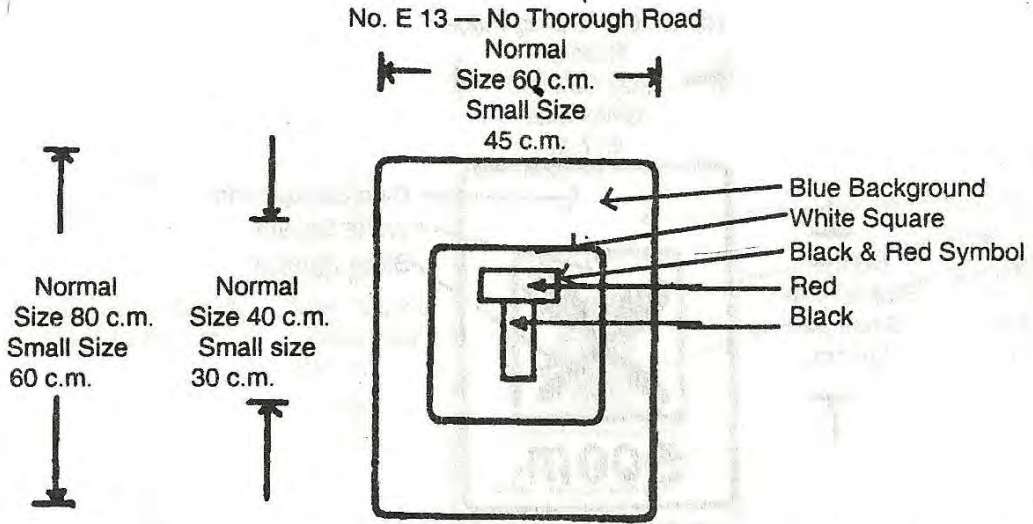

Note. On the blue band at the bottom of the sign, the distance to the facility or the direction may be inscribed in white.

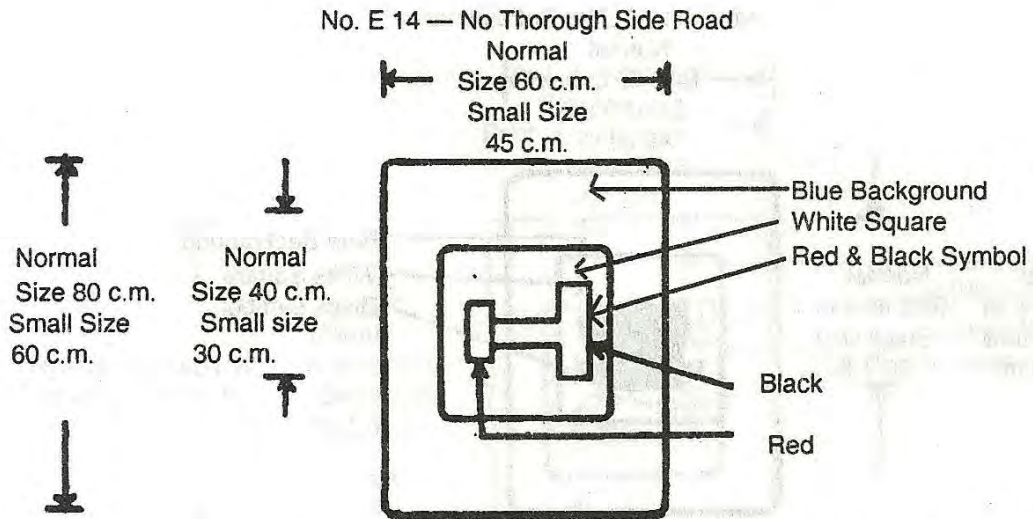

Note. On the blue band at the bottom of the sign, the distance to the facility or the direction may be inscribed in white.

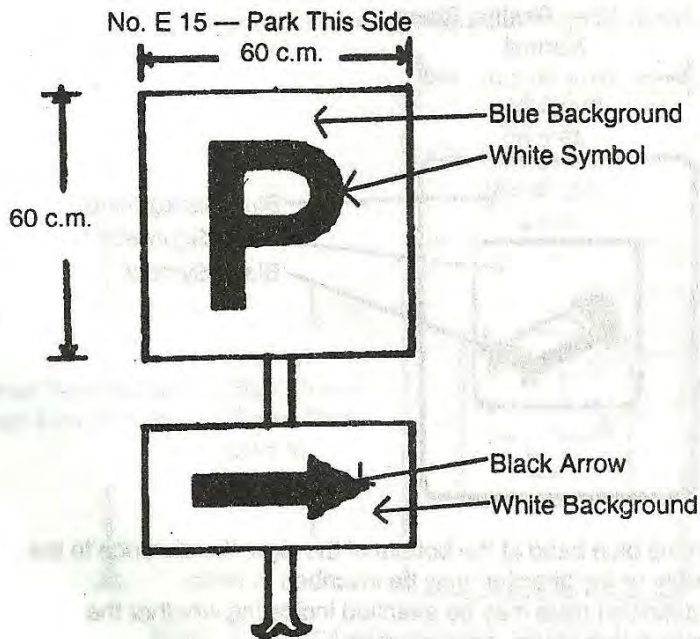

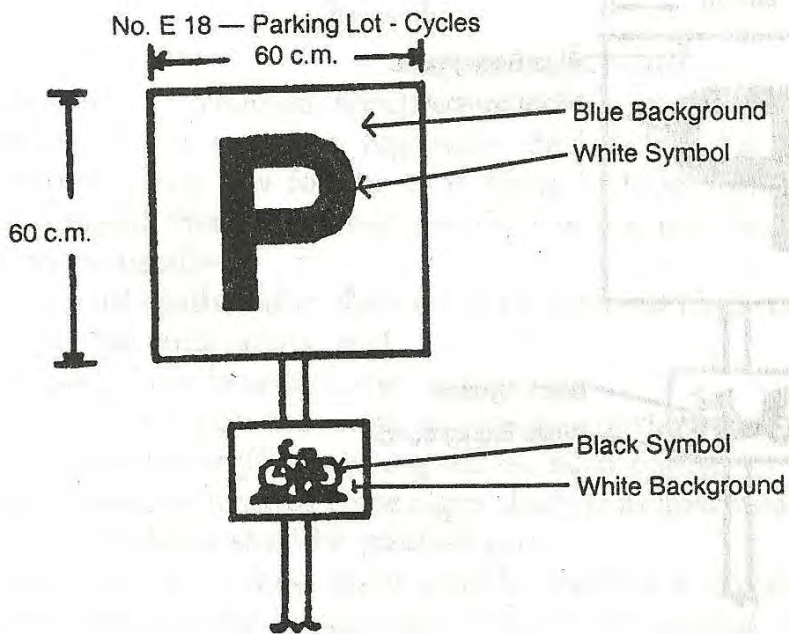
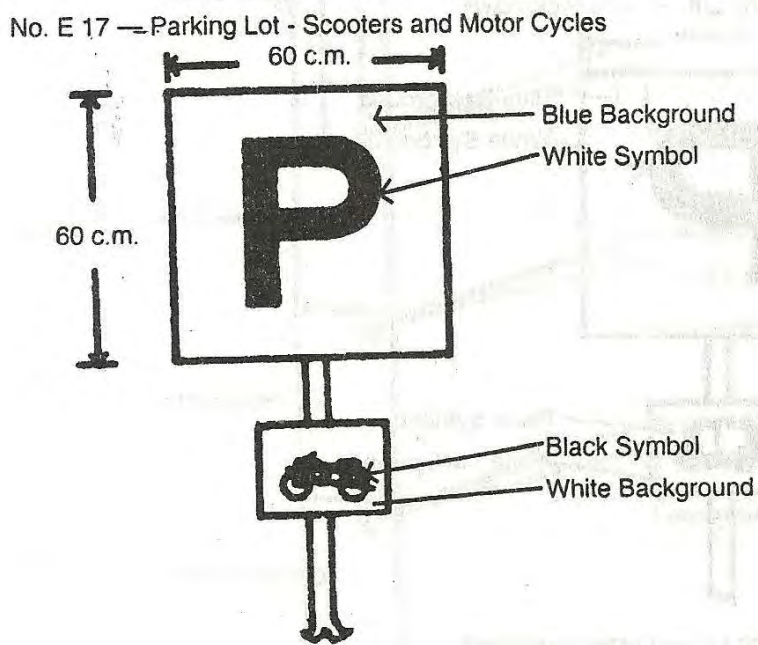
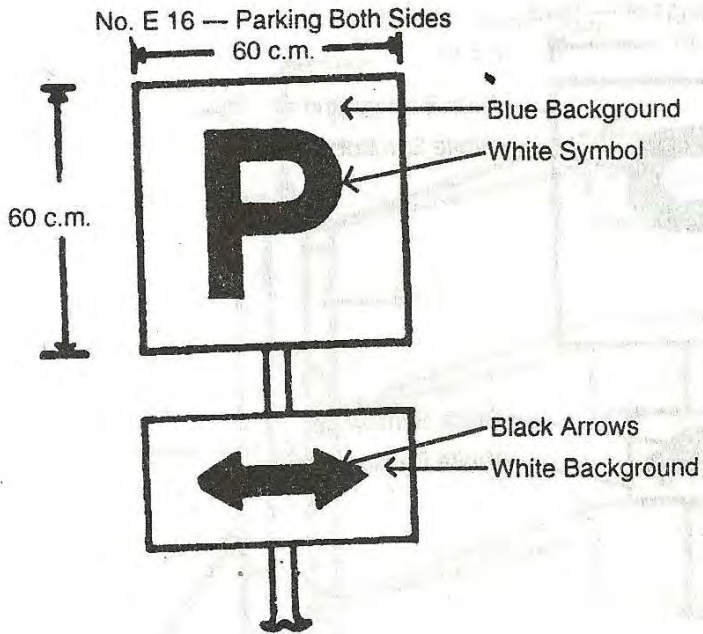

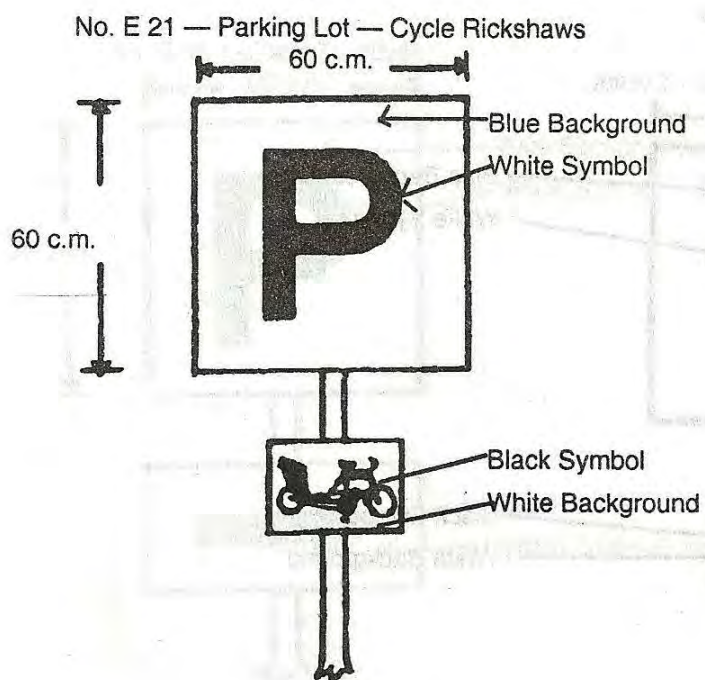
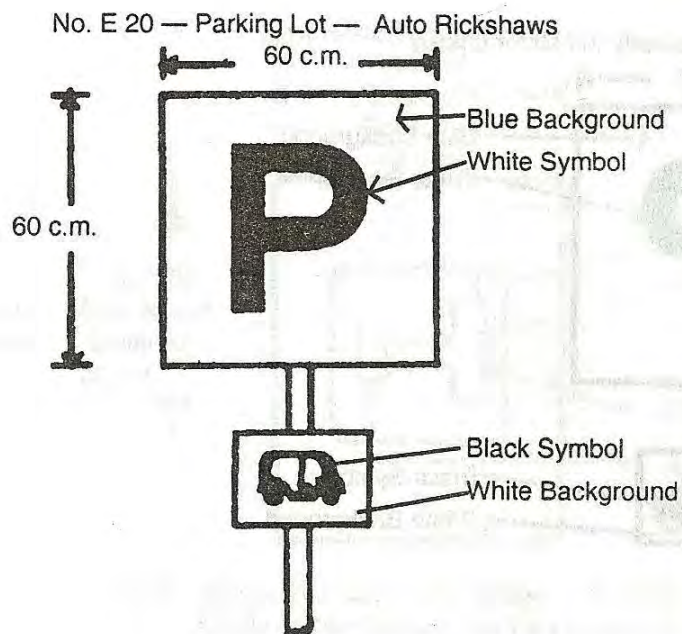
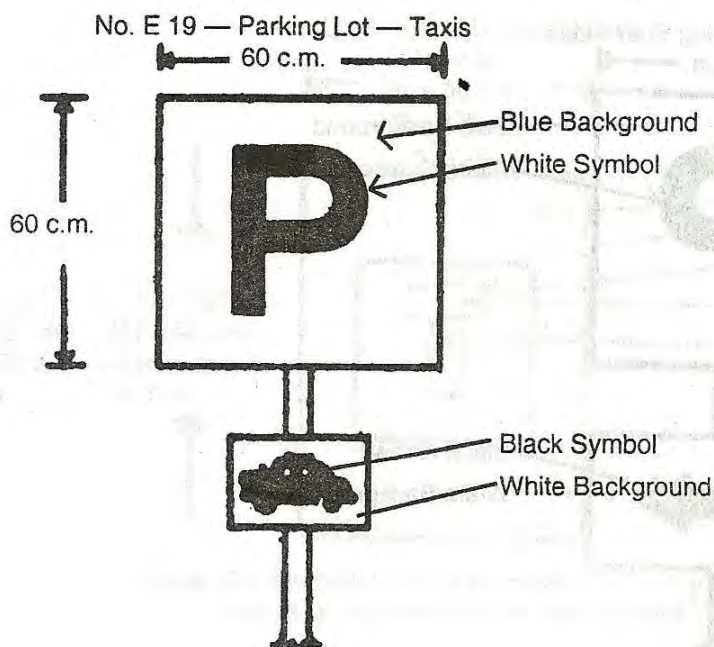

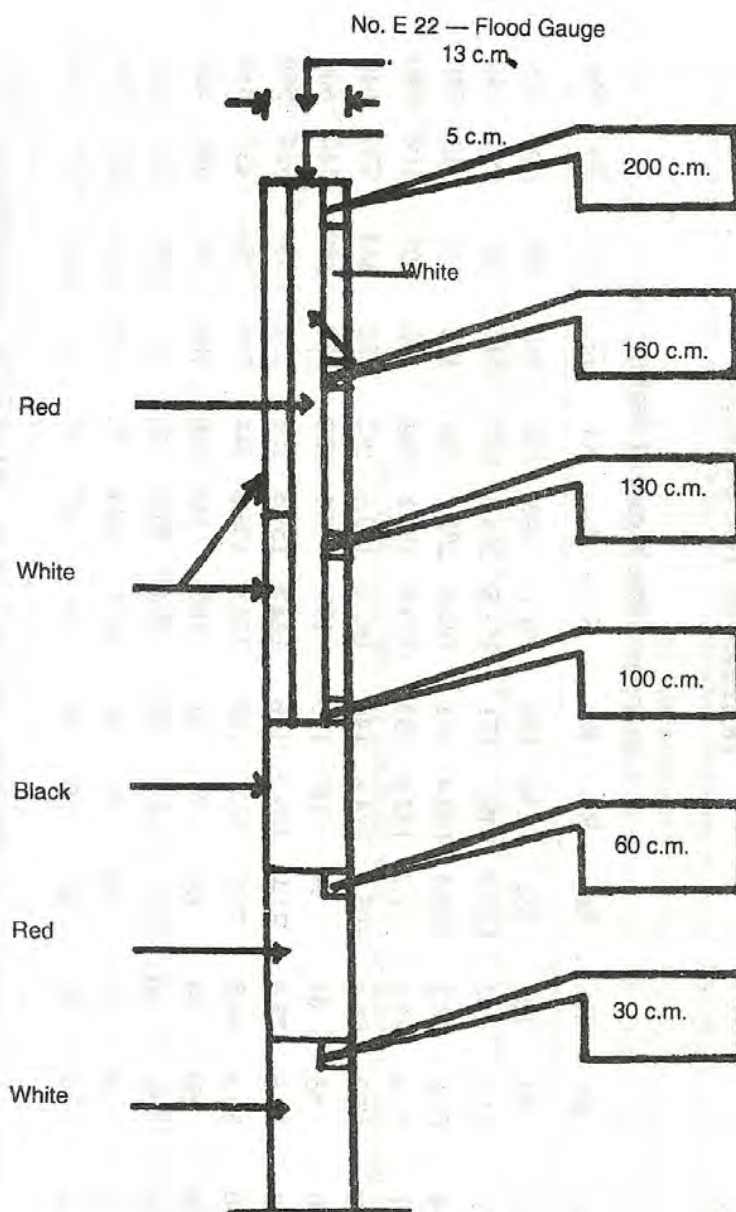

Explanatory Notes

(i) Normal Size, wherever specified, is the minimum size of the sign which is intended to be used in rural areas on highways declared to be National Highways or State Highways under any law for the time being in force in such rural areas;

(ii) the Small Size, wherever specified is the minimum size of the sign which is intended to be used,—

(a) on all roads, other than the said National Highways and the State Highways, in the rural areas, and

(b) on all roads within the urban areas:

Provided that sign of any appropriate size may be used on ballards or alongside traffic light signals on such roads;

(iii) the colour scheme of these signs shall be as specified therein and the reverse side of all such sign plates shall be painted grey;

(iv) the posts of all these signs shall be painted in 25 cms. wide bands, alternatively black and white and the lowest band next to the ground shall be black;

(v) the definition plate, wherever specified with a sign where required to make the meaning of a sign more explicit shall have white background, black letters and black border 20 mm. wide and shall be of adequate size for legibility but not too large as to be obtrusive.]

THE SECOND SCHEDULE

(See section 163A)

**SCHEDULE FOR COMPENSATION FOR THIRD PARTY FATAL
ACCIDENT/INJURY CASES CLAIMS****1. Fatal Accidents:**

Annual Income		Rs. 3000	Rs. 4200	Rs. 5400	Rs. 6600	Rs. 780	Rs. 900	Rs. 10200	Rs. 11400	Rs. 12000	Rs. 18000	Rs. 24000	Rs. 36000	Rs. 40000
AGE OF VICTIM	MUL TI- PLIE R	RUPEES IN (THOUSANDS)												
		Compensation in case of death												
		Rs	Rs.	Rs.	Rs.	Rs.	Rs	Rs	Rs.	Rs.	Rs.	Rs.	Rs.	Rs.
Up to 15 yrs.	15	60	84	108	132	156	180	204	228	240	360	480	720	800
Above 15 yrs. but not exdg. 20 yrs.	16	57	79.8	102	125.4	148 .2	171	193.8	216.6	228	342	456	684	760
Above 20 yrs. but not exdg. 25 yrs.	17	54	75.6	97.2	118.6	140 .4	162	183.6	205.2	216	324	432	648	720
Above 25 yrs. but not exdg. 30 yrs.	18	51	71.4	91.8	112.2	132 .6	153	173.4	193.8	204	306	408	612	680
Above 30 yrs. but not exdg. 35 yrs.	17	50	67.2	86.4	105.6	124 .8	144	163.2	192.4	192	288	384	576	640
Above 35 yrs. but not exdg. 40 yrs.	16	50	63	81	95	117	135	153	171	180	270	380	540	600
Above 40 yrs. but not exdg. 45 yrs.	15	50	58.8	75.6	92.4	109 .2	126	142.8	159.6	168	252	336	504	560
Above 45 yrs. but not exdg. 50 yrs.	13	50	50.4	64.8	79.2	93. 6	108	122.4	136.8	144	216	286	432	480
Above 50	11	50	50	54	66	78	90	102	114	120	180	240	360	400

yrs. but not exdg. 55 yrs.														
Above 55 yrs. but not exdg. 60 yrs.	8	50	50	50	52.8	62.4	72	81.6	91.2	96	114	192	286	320
Above 60 yrs. but not exdg. 65 yrs.	5	50	50	50	50	50	54	61.2	68.4	72	108	144	216	240
Above 65 yrs.	5	50	50	50	50	50	50	51	57	60	90	120	180	200

Note: The amount of compensation so arrived at in the case of fatal accident claims shall be reduced by 1/3rd in consideration of the expenses which the victim would have incurred towards maintaining himself had he been alive.

2. Amount of compensation shall not be less than Rs. 50,000.

3. General Damage (in case of death):

The following General Damages shall be payable in addition to compensation outlined above:

- (i) Funeral expenses -Rs. 2,000/-
- (ii) Loss of Consortium, if beneficiary is the spouse -Rs. 5,000/-
- (iii) Loss of Estate -Rs. 2,500/-
- (iv) Medical Expenses-Actual expenses incurred before death supported by bills/vouchers but not exceeding -Rs. 15,000/-

4. General Damages in case of Injuries and Disabilities:

- (i) Pain and Sufferings
 - (a) Grievous injuries -Rs. 5,000/-
 - (b) Non-grievous injuries -Rs. 1,000/-
- (ii) Medical Expenses-Actual expenses incurred supported by bills/vouchers but not exceeding as one time payment -Rs. 15,000/-

5. Disability in non-fatal accidents:

The following compensation shall be payable in case of disability to the victim arising on of non-fatal accidents: Loss of income, if any, for actual period of disablement not exceeding fifty two weeks.

PLUS either of the following:-

- (a) In case of permanent total disablement the amount payable shall be arrived at by multiplying the annual loss of income by the Multiplier applicable to the age on the date of determining the compensation, or
- (b) In case of permanent partial disablement such percentage of compensation which would have been payable in the case of permanent total disablement as specified under item (a) above.

Injuries deemed to result in Permanent Total Disablement/Permanent Partial Disablement and percentage of loss of earning capacity shall be as per Schedule I under Workmen's Compensation Act, 1923.

6. Notional income for compensation to those who had no income prior to accident:-

Fatal and disability in non-fatal accidents:-

- (a) Non-earning persons -Rs. 15,000 p.a
- (b) Spouse -Rs. 1/3rd of income of the earning/surviving spouse. In

case of other injuries only "General Damage" as applicable.]